

50 MHz Dual Channel Oscilloscope PM3217 / PM3217U

Service Manual

9499 445 00611

811215

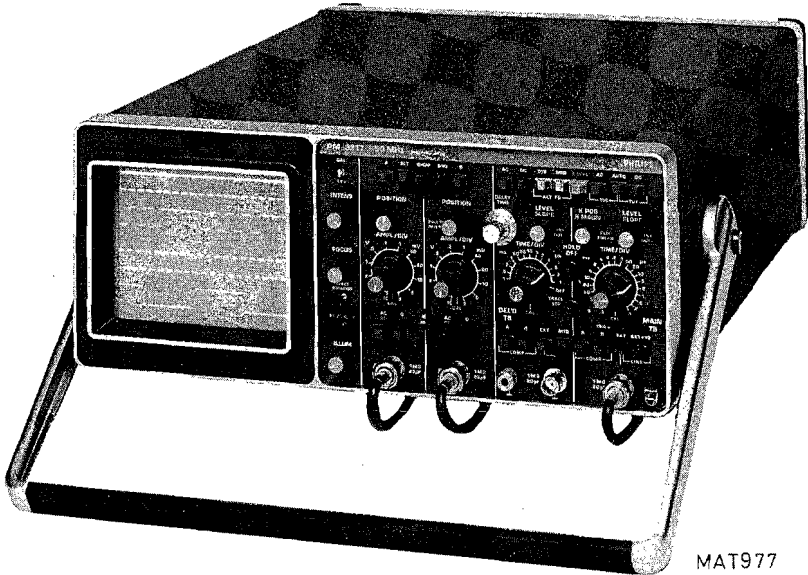

PHILIPS

IMPORTANT

In correspondence concerning this instrument, please quote the type number and serial number as given on the type plate.

NOTE: *The design of this instrument is subject to continuous development and improvement. Consequently, this instrument may incorporate minor changes in detail from the information contained in this manual.*

WICHTIG

Bei Schriftwechsel über dieses Gerät wird gebeten, die genaue Typenbezeichnung und die Gerätenummer anzugeben. Diese befinden sich auf dem Leistungsschild.

BEMERKUNG: *Die Konstruktion und Schaltung dieses Geräts wird ständig weiterentwickelt und verbessert. Deswegen kann dieses Gerät von den in dieser Anleitung stehenden Angaben abweichen.*

IMPORTANT

RECHANGE DES PIECES DETACHEES (Réparation)

Dans votre correspondance et dans vos réclamations se rapportant à cet appareil, veuillez TOUJOURS indiquer le numéro de type et le numéro de série qui sont marqués sur la plaquette de caractéristiques.

REMARQUES: *Cet appareil est l'objet de développements et améliorations continus. En conséquence, certains détails mineurs peuvent différer des informations données dans la présente notice d'emploi et d'entretien.*

CONTENTS

Page

1. GENERAL INFORMATION	1
1.1. Introduction	1
1.2. Characteristics	2
1.2.1. C.R.T.	2
1.2.2. Vertical of Y-axis	2
1.2.3. Horizontal or X-axis	3
1.2.4. Main time base	3
1.2.5. Delayed time base	3
1.2.6. X Deflection	4
1.2.7. Triggering of main time base	4
1.2.8. Triggering of the delayed time base	4
1.2.9. Calibration generator	5
1.2.10. Power supply	5
1.2.11. Environmental characteristics	5
1.2.12. Mechanical data	10
1.2.13. Z-mod input	10
2. CIRCUIT DESCRIPTIONS	11
2.1. Block diagram description	11
2.1.1. Y channel	11
2.1.2. Main time base triggering	11
2.1.3. Main time base circuit	11
2.1.4. Hold-off circuit	12
2.1.5. Z axis	12
2.1.6. Delayed time base	12
2.1.7. Delayed time base circuit	12
2.1.8. Alternate time base logic	12
2.1.9. Power supply	12
2.2. Description of the vertical section	13
2.2.1. Input coupling	13
2.2.2. Input attenuator	13
2.2.3. Impedance converter	13
2.2.4. Pre amplifier	13
2.2.5. Trigger pick-off	14
2.2.6. Normal invert switch	14
2.2.7. Position control	14
2.2.8. Channel multivibrator	14
2.2.9. Delay line driver	15
2.2.10. Composite trigger pick-off	16
2.2.11. Final Y amplifier	16
2.3. Main time-base triggering	16
2.3.1. Main time-base trigger source selection and preamplifier	16
2.3.2. Impedance converter and trigger comparator	16
2.3.3. Peak to peak level detector	17
2.3.4. T.V. Synchronisation separator	17
2.4. Main time-base generator	18
2.4.1. Main time-base sweep generator	18
2.4.2. Main time-base hold-off circuit	19
2.4.3. Main time-base sweep gating logic	19
2.4.4. Auto sweep circuit	21

2.5.	Delayed time-base triggering	21
2.5.1.	Delayed time-base trigger source selection amplifier	21
2.5.2.	Impedance converter and trigger comparator	21
2.6.	Delayed time-base generator	22
2.6.1.	Delayed time-base sweep generator	22
2.6.2.	Delayed time-base end of the sweep detector circuit	22
2.6.3.	Delay time function	23
2.6.4.	Comparator circuit	23
2.6.5.	Delayed time-base sweep gating logic	23
2.7.	X deflection selector and alternate time-base logic	24
2.8.	X final amplifier	26
2.9.	Cathode-ray tube circuit	26
2.9.1.	C.R.T. controls	26
2.9.2.	Beam blanking amplifier	27
2.10.	Power supply	29
2.10.1.	General	29
2.10.2.	Converter and stabilized power supply	29
2.10.3.	Illumination circuit	30
2.11.	Calibration unit	30
2.12.	Basic analog and digital circuits	31
2.12.1.	Basic analog circuits	31
2.12.2.	Basic digital circuits	32
3.	DISMANTLING THE INSTRUMENT	34
3.1.	Warning	34
3.2.	Removing the instrument covers	34
3.3.	Removing the carrying handle	35
3.4.	Access to parts for checking and adjusting procedure	35
4.	PERFORMANCE CHECK	36
4.1.	General Information	36
4.2.	Preliminary settings of the controls	36
4.3.	Recommended test equipment	37
4.4.	Checking procedure	38

5.	CHECKING AND ADJUSTING	43
5.1.	General information	43
5.2.	Recommended test equipment	43
5.3.	Preliminary of the controls	43
5.4.	Survey of adjusting elements and auxiliary equipment	44
5.5.	Checking and adjusting procedure	47
5.5.1.	Power supply	47
5.5.2.	Cathode-ray tube circuit	47
5.5.3.	Y-amplifier balance	48
5.5.4.	Trigger balance	49
5.5.5.	Time-base generators	49
5.5.6.	Vertical channels	51
5.5.7.	Triggering	53
5.5.8.	X-deflection	55
5.5.9.	Calibration voltage	56
5.6.	Adjustment interactions	57
6.	CORRECTIVE MAINTENANCE	58
6.1.	Replacements	58
6.1.1.	Replacing internal fuses and mains transformer	59
6.1.2.	Replacing single knobs	60
6.1.3.	Replacing double knobs	60
6.1.4.	Replacing delay-time multiplex knobs	60
6.1.5.	Removing the text plate	60
6.1.6.	Removing the front assembly	61
6.1.7.	Replacing switches	63
6.1.8.	Replacing the delay line unit	64
6.1.9.	Replacing the cathode-ray tube	64
6.2.	Soldering techniques	65
6.3.	Special tool	66
6.4.	Recalibration after repair	66
6.5.	Instrument repackaging	66
6.6.	Trouble-shooting	67
6.6.1.	Introduction	67
6.6.2.	Trouble-shooting hints	67
6.6.3.	Mains transformer data	68
6.6.4.	Voltages and waveforms in the instruments	68
6.6.5.	Component location list	70
6.7.	Mains voltage settings	73
6.8.	Checks after repair and maintenance	73
6.8.1.	Checking the protective leads	73
6.8.2.	Checking the insulating resistance	73

6.9.	Extra in- and output circuits	74
6.9.1.	External Z-modulation input	74
6.9.2.	Main-time base sweep output	74
6.9.3.	Main-time base gate output	75
6.9.4.	Delayed time base gate output	75
6.10.	Accessory information	77
7.	PARTS LISTS	81
7.1.	Mechanical parts	81
7.1.1.	Spare parts for pushbutton switches	82
7.2.	Electrical parts	83
8.	CIRCUIT DIAGRAMS AND PRINTED CIRCUIT BOARD LAY-OUTS	105

1. General information

1.1 INTRODUCTION

The 50 MHz dual-channel oscilloscope PM 3217 and PM 3217U is a compact, portable instrument, ergonomically designed to facilitate its extensive measuring capabilities.

The instrument provides both a main and a delayed timebase with provision for alternate timebase displays, comprehensive triggering facilities including peak-to-peak Auto, DC coupling and automatic TV waveform display.

A large 8 x 10 cm screen with illuminated internal graticule lines makes for easier viewing, and a 10 kV accelerating potential gives a high intensity trace with a well-defined spot.

The wide range of applications enabled by the above features is further extended by a versatile power supply that enables the instrument to be operated from different line voltages as well as from d.c. For field operation an optional battery version is also available.

This service manual contains all service information about the PM3217 and PM3217U.

For operating instructions, refer to the Operating manual which also contains accessory information.

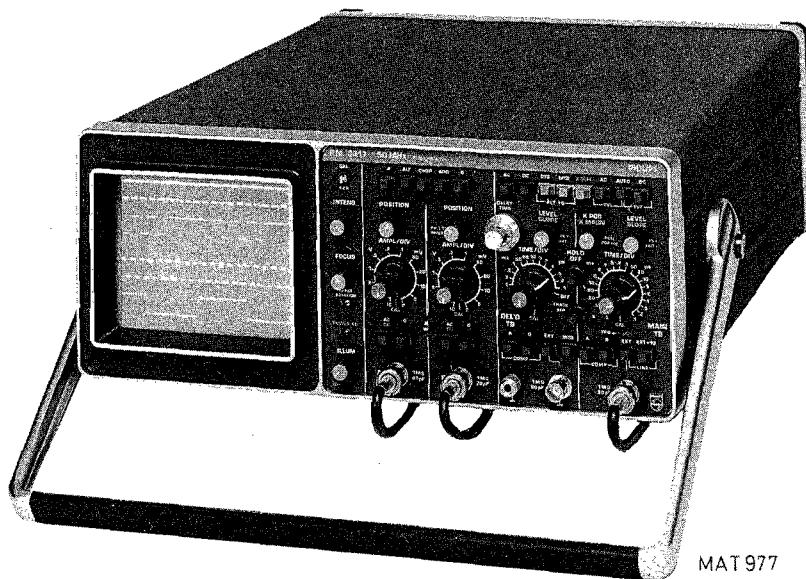

Fig. 1.1.

1.2. CHARACTERISTICS

This instrument has been designed and tested according to IEC Publication 348 first edition for Class I Instruments* and UL 1244** and has been supplied in a safe condition. This Manual contains information and warnings which shall be followed by the purchaser to ensure safe operation and to retain the instrument in a safe condition.

- This specification is valid after the instrument has warmed up for 30 minutes (reference temperature 23°C).
- Properties expressed in numerical values with tolerance stated, are guaranteed by the manufacturer.
- Numerical values without tolerances are typical and represent the characteristics of an average instrument.
- Inaccuracies (absolute or in %) relate to the indicated reference value.

<i>Designation</i>	<i>Specification</i>	<i>Additional Information</i>
1.2.1 C.R.T.		
Type	D14-125 GH/08	Rectangular tube face, mesh type, post accelerator, metal backed phosphor.
Measuring area	8 x 10 divisions	1 div. equals 1 cm
Screen type	P31 (GH)	P7 (GM) optional
Total acceleration	10 kV	
Graticule	Internal	Cont. variable illumination
Engravings	Centimetre divisions with subdivisions of 2 mm along the central axes. Dotted lines indicate 10% and 90% of measuring lattice for measurement of rise time.	
1.2.2 Vertical or Y-axis		
Display modes	Channel A only Channel B only A and B chopped A and B alternating A and B added	
Channel B polarity	Normal or inverted	
Response:		
Frequency range	DC: 0 50MHz (-3dB) AC: 2 Hz 50MHz (-3dB)	
Rise time	≤ 7ns	
Pulse aberrations	≤ ± 3% (≤ 5% pp)	Measured at 6 div. amplitude and applied rise time of ≥ 1 ns.
Deflection coefficients	2 mV/DIV 10 V/DIV	1-2-5 sequence
Continuous control range	1 : ≥ 2,5	
Deflection accuracy	± 3 %	
Input impedance	1 MΩ/20 pF	
Input RC time	0,1 s	Coupling switch to AC
** Maximum safe input voltage	400V (dc + ac peak)	
* Rated input voltage	42 V (dc + ac peak)	Test voltage 500 V (r.m.s.) According to IEC 348
Chopping frequency	≈ 500 kHz	
Vertical positioning range	16 divisions	
Dynamic range	24 divisions	
Visible signal delay	≥ 2 divisions	At 10ns

* only PM3217

** only PM3217U

C.M.R.R. in A-B mode	≥ 40 dB at 1 MHz	After adjustment at d.c. or low frequencies
Cross talk between channels	-40 dB or better at 10 MHz	Both attenuators in the same setting
Instability of the spot position:		
Temperature drift	$\leq 0,3$ div/hour	

1.2.3 Horizontal or X-axis

Horizontal deflection can be obtained from either the Main time base or the Delayed time base or a combination of the two, or from the signal source selected for X-deflection. In this case X-Y diagrams can be displayed using A, B, the Ext input connector, or Line as a signal source for horizontal deflection.

Display modes

– Main time base		
– Main time base intensified by delayed time base		
– Main time base and delayed time base alternately displayed		
– Delayed time base		
– XY or XY/Y operation		
		X deflection by:
		– Channel A signal
		– Channel B signal
		– Signal applied to EXT connector of main time base
		– Line frequency

1.2.4 Main time base

Operation	Automatic	Possibility of automatic free-running in the absence of triggering signals
	Triggered	
Time coefficients	0,5 s/DIV 0,1 μ s/DIV	1-2-5 sequence
Continuous control range	1 : $\geq 2,5$	
Coefficient error	$\pm 3\%$	$\pm 5\%$ including x10 magnifier
Magnification	10x	
Max. effective time coefficient	10 ns/DIV	

1.2.5 Delayed time base

Operation	Delayed time base either starts immediately after delay time or is triggerable after the delay time, by the selected delayed time base trigger source	
Time coefficients	1 ms/DIV – 0,1 μ s/DIV	1-2-5 sequence
Continuous control range	1 : $\geq 2,5$	
Coefficient error	$\pm 3\%$	
Delay time	In steps variable with main time base. Continuously variable with 10-turn potentiometer between 0 x and 10 x the time coefficient of the main time base	
Incremental delay time accuracy	0,5%	
Delay time jitter	1 : ≥ 20.000	

<i>Designation</i>	<i>Specification</i>	<i>Additional information</i>
1.2.6 X Deflection		
Source	A, B, EXT, EXT ÷ 10 or LINE	As selected by trigger source switch, if push-button X DEFL. is depressed
Deflection coefficients	A or B: As selected by AMPL/DIV EXTERNAL : 0,2 DIV EXT ÷ 10 : 2V/DIV LINE 8 divisions at nominal line voltage.	
Deflection accuracy	± 10%	
Frequency range	DC: 0 1 MHz (-3 dB) over 6 divisions	
Phase shift	≤ 3° at 100 kHz	
Dynamic range	24 divisions	For frequencies ≤ 100 kHz
1.2.7 Triggering of the main time base		
Source	Ch. A, Ch. B, Composite, External ÷ 10 and line	
Trigger mode	Automatic, normal AC normal DC, TV-line and TV frame	
Trigger sensitivity	Internal: 0,5 div (DC 5 MHz) 1 div (5MHz 50 MHz) External : 150 mV (DC 5MHz) 200 mV (5MHz 50MHz) Ext. ÷ 10 : 1,5V (DC 5MHz) 2V (5MHz 50MHz)	
Triggering frequency range	AUTO: 20 Hz..... ≥ 50 MHz AC: 5 Hz..... ≥ 50 MHz DC: 0 Hz..... ≥ 50 MHz	
Level range	AUTO: Proportional to peak-to-peak value of trigger signal. AC, DC: 8 div. at internal trigg., 1,6V at external trigg. and 16V at ext ÷ 10	+ or - 4 div. and + or - 0,8V referenced to centre of screen + or - 8V referenced to centre of screen.
Triggering slope	Positive or negative going	
Input impedance	1 MΩ//20 pF	
**  Maximum safe input voltage	400V (dc + ac peak)	
* Rated input voltage	42V (dc + ac peak)	Testvoltage: 500V (r.m.s.) according to IEC348
Hold-off time	variable	
1.2.8 Triggering of the delayed time base		
Source	chA, chB, Composite, External, MTB.	
Trigger sensitivity	Internal: 2 div. (DC 50MHz)	External: 400mV (DC ... 50MHz)
Other trigger specifications are identical to "triggering of the main time base" with the exception of the trigger modes EXT. ÷ 10, TV and AUTO.		

<i>Designation</i>	<i>Specification</i>	<i>Additional Information</i>
1.2.9 Calibration generator		
Output voltage	1,2 V _{pp}	Square wave
Accuracy	± 1%	
Frequency	≈ 2 kHz	
1.2.10 Power supply		
AC supply:		
Nominal voltage range (on line-mains voltage adaptor)	110, 127, 220 or 240 Vac ± 10%	
Nominal frequency range	50 400 Hz ± 10%	
Power consumption	30 W max.	At nominal mains voltage
Battery supply:		
Voltage range	22-27 V dc 20-28 V	Battery minus (–) connected to chassis with relaxed specifications
Current consumption	1,1 A max.	
Capacity to earth	185 pF 27 pF	Measured with rubber feet on grounded metal plate of 1 m ² Measured 30 cm above grounded plate of 1 m ²
1.2.11. Environmental characteristics		
<i>The environmental data are valid only if the instrument is checked in accordance with the official checking procedure. Details on these procedures and failure criteria are supplied on request by the PHILIPS organisation in your country, or by N.V. PHILIPS' GLOEILAMPENFABRIEKEN, TEST AND MEASURING DEPARTMENT, EINDHOVEN, THE NETHERLANDS.</i>		
Ambient temperatures:		
Rated range of use	+ 5°C ... +40°C	
Operating	–10°C ... +55°C	
Storage and transport	–40°C ... +70°C	
Altitude:		
Operating to	5000 m (15000 ft)	
Non-operating to	15000 m (45000 ft)	
Humidity	21 days cyclic damp heat 25°C –40°C, R.H. 95%	
Shock	30 g: half sinewave shock of 11ms duration: 3 shocks per direction for a total of 18 shocks	
Vibration	Vibrations in three directions with a maximum of 15 min. per direction, 5 – 55 Hz and amplitude of 0.7mm _{pp} and 4g max. acceleration. Unit mounted on vibration table without shock absorbing material.	
Electromagnetic interference	Meets VDE 0871 and VDE 0875 Grenzwertklasse B.	

—

ssis

ded

ite

G

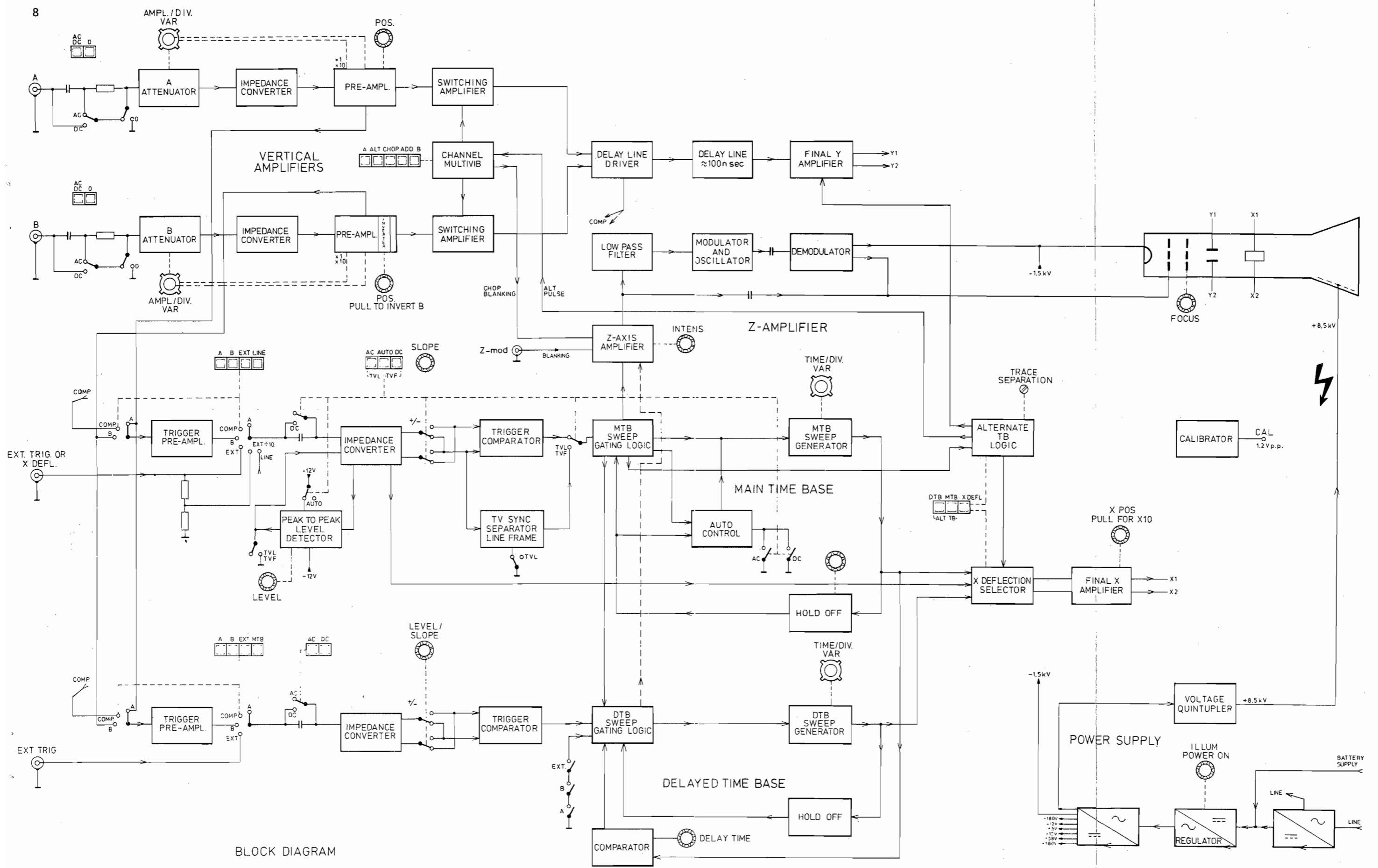

BLOCK DIAGRAM

Fig. 2.1. Block diagram

1.2.12 Mechanical data

Dimensions:

Length 445 mm
 Width 335 mm
 Height 137 mm
 Weight 8,4 kg (18,5 lb) approx.

Handle and controls excluded
 Handle excluded
 Feet excluded

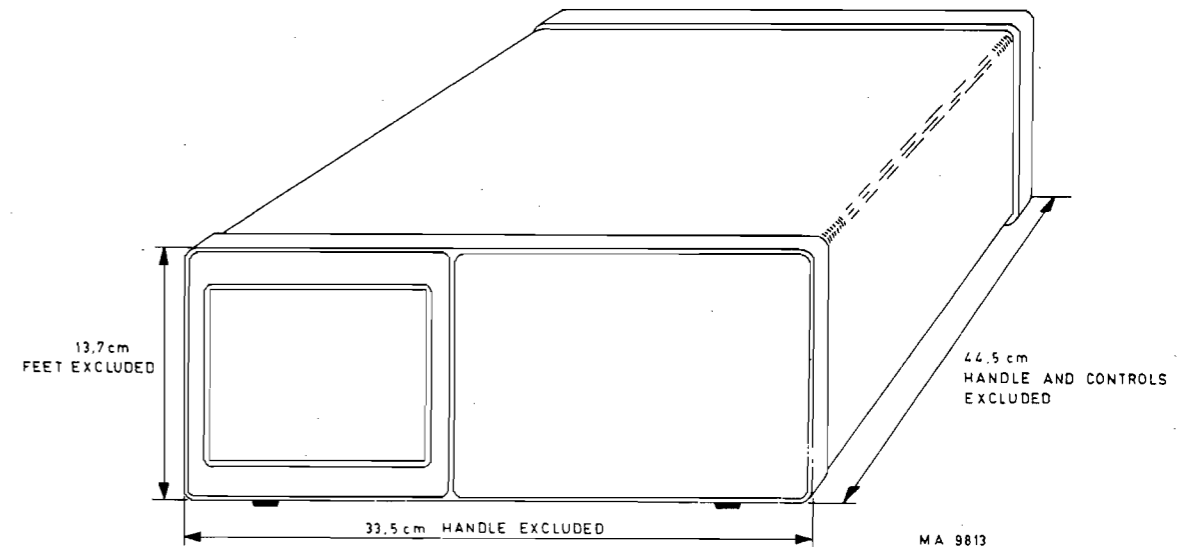
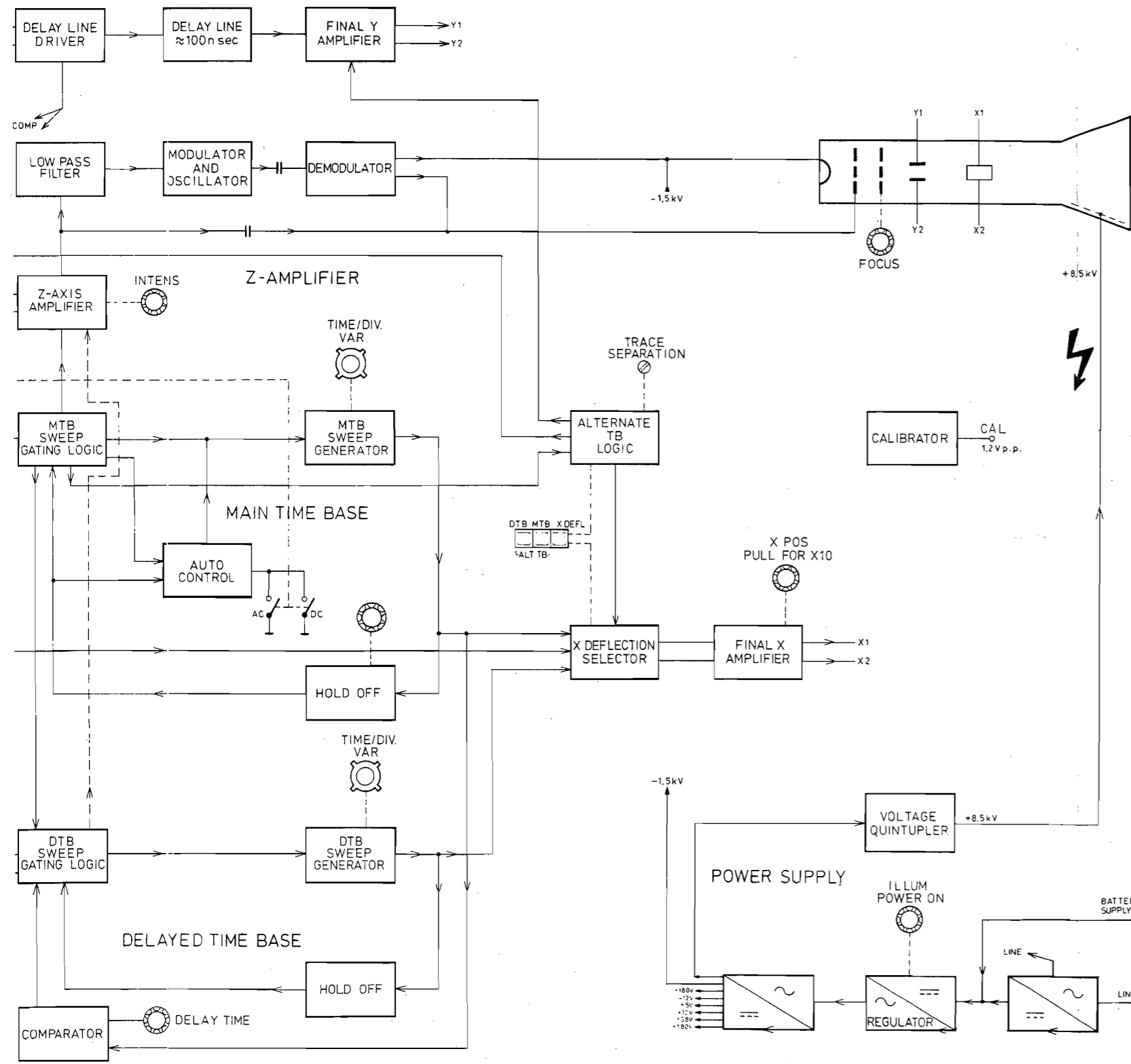

Fig. 1.2

1.2.13. Z-mod input

0V = off
 + 5V or not connected = on



2. CIRCUIT DESCRIPTIONS

In chapter 2.1. the block diagram description is given and in the chapters 2.2. – 2.11. the detailed circuit information is described.

Additional the most important characteristics of the analog and digital circuits are described in chapter 2.12.

2.1. BLOCK DIAGRAM DESCRIPTION (see fig. 2.1.)

This chapter serves to explain the main functions of the oscilloscope. The working principle is divided into the following sections.

2.1.1. Y Channel

The vertical channels A and B for the signals to be displayed are identical, each comprising an input coupling switch, an input step attenuator, an impedance converter and a preamplifier with trigger pick-off.

A channel multivibrator, controlled by the display mode pushbuttons, switches either channel A or channel B to the final Y amplifier via the delay line. The channel multivibrator is operated by a pulse at the end of the sweep, and offers an uninterrupted display of the A and B waveforms in the ALT mode. In the ADD position, both switching amplifiers couple the signals through, thus adding channels A and B. By inverting the B channel amplifier (PULL TO INVERT B) the A – B mode is obtained.

The AMPL/DIV switches provide x 1 or x 10 gain control of the preamplifier, which offers in conjunction with the step attenuator a full range of deflection coefficients in a 1-2-5 sequence.

2.1.2. Main time base triggering

To initiate sweeps, trigger signals can be derived from the A and B vertical channel preamplifiers, from an external source, or internally from the mains supply (LINE triggering) as selected by the trigger source switch. Composite triggering (A and B depressed) is derived from the delay-line driver stage. The polarity of the trigger signal, negative or positive-going, on which the display will start is determined by changing the output polarity of the impedance converter.

With the AUTO switch depressed, the peak-to-peak level detector comes into operation. The peak-to-peak level of the signal then determines the range of the LEVEL control.

With AC or DC depressed, the range of the LEVEL control is fixed.

In the TVL and TVF modes the LEVEL control is inoperative and the TV sync separator is switched into circuit, thus initiating sweeps with line or frame pulses depending on the setting of the TVL and TVF switches.

2.1.3. Main time base circuit

For normal internal time base operation the horizontal amplifier is fed by sweeps from the time base circuit. With AUTO depressed, in the absence of trigger signals, the output of the sweep generator is fed back via the hold-off circuit and gate to its input. This causes sweeps to free-run and a resultant trace is displayed on the screen. As soon as the AUTO control circuit detects a trigger (i.e. a change in the output of the sweep-gating logic) the sweep is fed back to the sweep-gating logic. This causes the circuit to revert to the normal triggering mode in which sweeps are initiated only by trigger pulses at the input of the sweep-gating logic.

With AC or DC depressed, AUTO control is made inoperative. Sweeps are then only produced provided a trigger signal is present and the LEVEL control appropriately set.

The display can be magnified in the horizontal direction by increasing the gain of the final amplifier by a factor of x10 (also the X DEFL mode).

When the X DEFL pushbutton of the horizontal selection switch is depressed, the sweep generator output to the final amplifier is inhibited and the impedance converter is connected directly to the final amplifier. In this way, the signals normally selected for triggering, or an external source, can now be used for horizontal deflection.

2.1.4. Hold-off circuit

The hold-off stage, as its name implies, "holds-off" triggers from the input of the time base circuit until the trace has completely returned and the time base circuits are completely reset. The hold-off time can be decreased by turning the HOLD-OFF control clockwise.

2.1.5. Z Axis

The Z amplifier provides for the blanking of the trace during the fly-back and hold-off time. In addition, it blanks the sweep in the CHOP mode during the switching transients. More over the trace can be blanked by a signal applied to the external Z-mod input. The l.f. components of the blanking signal are modulated and demodulated before they are applied to the Wehnelt cylinder together with the a.c. coupled h.f. components.

2.1.6. Delayed time base triggering

To initiate sweeps, trigger signals can be derived from the A and B vertical channel preamplifiers, or from an external source as selected by the trigger source push button switch.

With both the A and B pushbuttons depressed simultaneously, composite triggering is derived from the delay-line driver stage of the Y amplifier channel. AC and DC coupling is provided to the impedance converter. The polarity of the trigger signal, negative or positive-going, on which the display will start, is determined by changing the output polarity of the impedance converter by the SLOPE switch.

With MTB selected, the delayed time base starts directly after the delay time. The DELAY TIME control in conjunction with the comparator determines the delay time for the delayed time base generator.

2.1.7. Delayed time base circuit

The delayed time base is operative unless its TIME/DIV switch is in the OFF position. It starts immediately after the delay time, or upon receipt of the first trigger pulse after the delay time.

The sawtooth signal derived from the main time base sweep generator is passed to a comparator where it is compared with an accurately adjustable d.c. voltage, controlled by the DELAY TIME control.

The comparator output is pulse-shaped and provides the required delay pulse for the sweep-gating logic of the delayed time base generator. A sawtooth voltage is then initiated.

The delayed sweep is reset by the hold-off circuit of the delayed time base (end of the sweep detection) or by the main time base.

It can be started again by the output signal of the comparator after the initiation of the next main time base sweep.

When pushbutton MTB of the horizontal deflection mode controls is selected, the part of the trace coinciding with the delayed sweep is intensified.

2.1.8. Alternate time base logic

In ALT TB mode an electronic switch enables main time base display and delayed time base display to be alternately traced on the screen.

The two displays can be separated by varying the voltage applied to the vertical amplifier, derived from the driving circuits of the electronic switch. This separation is symmetrically variable by means of the TRACE SEPARATION control on the front panel.

In the ALT TB mode the vertical channel multivibrator is controlled by a signal derived from the electronic switch.

In the vertical and horizontal ALT modes, successively are displayed on the screen, Channel A and main time base, Channel A and delayed time base, Channel B and main time base, Channel B and delayed time base.

2.1.9. Power supply

The mains (line) supply is transformed and rectified before being applied to a d.c. to a.c. converter. When the instrument is operated from a battery supply, the battery output is connected directly to the d.c. to a.c. converter.

The output of the regulator is coupled to a transformer and rectifier which, after rectification, provides the -1.5 kV potential and the circuit supply voltages. The -1.5 kV is also multiplied to 8.5 kV to supply the required total accelerating voltage of ≈ 10 kV.

2.2. DESCRIPTION OF THE VERTICAL SECTION

The vertical channels A and B for the signals to be displayed are identical, each comprising an input coupling switch, an input step attenuator, an impedance converter and a preamplifier with trigger pick-off facility. A channel multivibrator, controlled by the display mode pushbuttons, switches either channel A or channel B to the final Y amplifier via the delay line driver and the delay line. The final Y amplifier feeds the Y deflection plates of the cathode-ray tube.

The individual stages of the vertical deflection system are now described in detail.

As the signal paths for channel A and channel B are basically identical, only the channel B signal path is described.

2.2.1. Input coupling

Input signals connected to the BNC input socket X3 can be a.c. coupled, d.c. coupled or internally disconnected. In the AC position of S19, there is a capacitor (C401) in the signal path. This capacitor prevents the DC component of the input signal from being applied to the amplifier.

In position DC of switch S19, the input signal is coupled directly to the step attenuator.

At the same time, blocking capacitor C401 is discharged via R402, to prevent damage of the circuit under test by a possible high charge.

S20 (0) isolates the B input signal and earths the channel input for reference purposes; e.g. for calibration or centering the trace.

2.2.2. Input attenuator

The input attenuator is a frequency-compensated, high-impedance voltage divider with twelve positions. The overall attenuation of the stage is determined by the combination of the selected sections of two voltage dividers. The various combinations are selected by the twelve positions of the frontpanel AMPL/DIV attenuator switch S11.

The first divider sections attenuate by a factor of 1.25, 3.125 and 6.25 and the second divider sections attenuate by a factor of 1x, 10x and 100x.

With the overall combinations of attenuation, nine different deflection coefficients are realised from 20 mV/div. to 10 V/div. in a 1-2-5 sequence. Only for the most sensitive positions 2 mV/div., 5 mV/div. and 10 mV/div. of AMPL/DIV attenuator switch S11, the gain of the Y amplifier is increased by a factor of 10. The input capacitance of the attenuator cannot be adjusted in the individual positions. Small differences of approx. 1 pF are allowed.

Capacitor networks are provided in the voltage divider sections to make them frequency impedant.

2.2.3. Impedance converter

The impedance converter is formed by V604 (two matched field-effect transistors). The two FET transistors are used in source follower configuration.

The signal level on the gate (and on the source) of the upper FET amounts to 1,6 mV/div. or 16 mV/div. Diode V601 together with the output impedance of the attenuator and also the attenuator action protects the input source follower against excessive negative input signals. The d.c. balance of the circuit can be adjusted with R604, providing attenuator balance for the 10 mV/div. and 20 mV/div. positions.

2.2.4. Preamplifier

The input stage formed by D601 (5 transistors) is switched in a Cherry-Hooper configuration and direct coupling is employed throughout.

In the positions 20 mV/div – 10 V/div of the AMPL/DIV switch S8, contact K601 is open and the gain is determined by

$$\frac{R628 + R632}{R611 + R612} = \text{approx. } 1,8x$$

If K601 is closed (in positions 2 mV/div, 5 mV/div and 10 mV/div) the gain of this stage is increased by a factor of 10. This is accurately adjusted with R621.

To prevent jumping of the trace when K601 is switched with the input short circuited, no voltage must be present across these contacts. R604 (attenuator balance) serves this purpose.

R8 in conjunction with R622, R623, R624 and R626 forms the vernier control. In the calibrated position (R8 is 1 kohm) the transfer of this network is 0,85x. With R8 to its minimum position (0 ohm) the transfer is 0,3x. Thus we have a control range of 3x.

V608, V609, V613, V614, V616 and V617 form a symmetrical cascode circuit supplying an output CURRENT to the channel switch.

The transfer conductance of this stage is:

$$\frac{I_{out}}{U_{in}} = \frac{1}{R641 // (R637 + R638) // (R646 + R647 + R648)} = 7 \text{ mA/V}$$

The signal level at the input of this stage is approx. 24 mV/div equivalent to approx. 170 μ A/div at the output.

Note: The channel A gain can be equalised to the channel B gain with the aid of R543 (gain x1 in channel A amplifier).

2.2.5. Trigger pick-off

The trigger signal is picked-off at the emitters of V608 and V609, a signal source with a low internal resistance, by the series feed-back stage V611 and V612.

From this stage the trigger signal currents are fed symmetrically to the main time base and delayed time base trigger selectors via 50 Ohm cables.

2.2.6. Normal invert switch

The B channel has a provision for inverting the polarity of the Y signal. Push-pull switch S5, PULL TO INVERT B, is mounted on the shaft of front-panel control B POSITION. In the invert position of the switch the normal signal paths are blocked because V613 and V614 are switched off.

Inversion is achieved by V616 and V617 providing alternative paths for the signal when their bases are switched less positive by S5. Possible unbalance between the two positions of the switch can be compensated by preset potentiometer R647 normal/invert balance.

2.2.7. Position control

Potentiometer R3 is the vertical POSITION control. Its balance is adjustable by means of R674 (shift balance).

2.2.8. Channel multivibrator

The channel multivibrator consists of two circuits which are inserted in the A and B channel signal paths. The A channel circuit consists of the transistors V524, V526 and the diodes V521, V522 and V523. The B channel circuit consists of the transistors V624 and V626 and the diodes V621, V622 and V623.

When the junction of the three diodes is positive in relation to mass, the diodes are non-conductive. The transistors, and thus, the signal path are conductive.

If the current drained from the junction exceeds 6 mA, the diodes are conductive and the transistors are turned off.

The circuits are driven from the flip-flop formed by the transistors V703 and V704.

With A (S1A) depressed: only channel A is displayed.

The base of V703 is connected to the -12 V supply voltage.

V703 is turned-off then, its collector voltage is high and channel A is switched on. At the same moment channel B is switched off.

With ALT (S1B) depressed: channels A and B are alternately displayed.

This push-button is a dummy and has no contacts, but it releases all the other push-buttons of the display-mode controls. In this mode there is a DC path via R704 between the two emitters, the circuit is bi-stable and one of the diodes is conductive.

V1668 is not conducting in ALT mode and negative going alternate pulses derived from the alternate time-base logic are fed to the circuit. These pulses switch the circuit at the end of each sweep and the channels A and B are alternately displayed.

In ALT TB mode the circuit is switched at the end of every two sweeps.

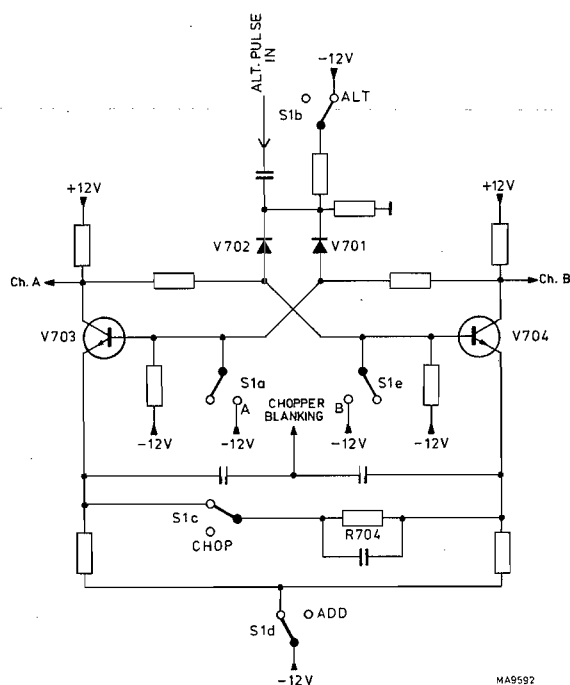

Fig. 2.2. Simplified diagram of the channel multivibrator

In the ALT mode -12 V is applied via S1A, S1C, S1D and S1E and R1687 to transistor V1511 in the beam blanking amplifier. This transistor is then blocked and the only control signals for the beam unblanking amplifier are the normal unblanking pulses coming from the time-base circuits.

With CHOP (S1C) depressed: channels A and B are chopped.

In this mode the circuit acts as a chopper generator. S1C is open then, the DC path between the emitters of V703 and V704 is interrupted and the circuit is a-stable. Both diodes V701 and V702 are then turned-off and the circuit starts oscillating, the oscillating frequency being approx. 500 kHz.

During the switching transients in the CHOP mode, the c.r.t. is blanked with the aid of differentiated chopper blanking pulses (at the junction of R703 and C704) which are fed to the Z-amplifier.

With ADD (S1D) depressed: channel A and B are added. Both transistors are turned-off, both collector voltages are high and both channels are switched on.

With B (S1E) depressed: only channel B is displayed.

The base of V704 is connected to the -12 V supply voltage. V704 is then turned-off, its collector voltage is high and channel B is switched on. At the same moment channel A is switched off.

2.2.9. Delay line driver

The symmetrical delay line is sandwiched between a series feed-back push-pull amplifier (called CHERRY) and a shunt feed-back push-pull amplifier (called HOOPER), consisting of integrated circuit D801.

Such an amplifier combination is called "CHERRY-HOOPER".

The series feed-back stage receives a signal of approx. 30 mV/div. which is obtained from a signal current of $0,17\text{ mA/div.}$ from the channel switch, multiplied by the value of the load resistance $R803 + R804 = 2000\text{ Ohm.}$

The emitter impedance of the series feed-back stage consists besides $R_E = R819 + R821$ of the parallel circuit of a number of RC networks. As the delay line is a source of distortion for higher frequencies, these networks are realizing the necessary delay line compensation.

At the input side, delay line D802 terminates in R828 and R829 (totally 200 Ohm).

The delay line itself is a symmetrically mount spiralized cable with a characteristic impedance of 200 Ohm and a delay of 110 nsec/m. At the output side, the cable terminates via R831 and R832 in the virtual earth points of the parallel feed-back stage (HOOPER). The input impedance on these virtual earth points is 14 Ohm. This value in series with the 86,6 Ohm of R831 and R832 forms the correct termination for the delay line. C814 and C816 are for HF correction.

2.2.10. Composite trigger pick-off

The composite trigger signal is picked-off at the emitters of the CHERRY stage (D801), a signal source with a low internal resistance, by the series feed-back stage V802 and V803. From this stage the composite trigger signal currents are fed symmetrically to the main time-base and delayed time-base trigger selectors via 50 Ohm cables.

2.2.11. Final Y amplifier

The output signals of the "HOOPER" stage are applied to the final Y amplifier stage consisting of the transistors V804, V806, V807 and V808, which are configured as two series feed-back amplifiers in parallel fed by a constant current source.

The gain of the final amplifier can be set by means of potentiometer R848. The centre taps of the coils L801 and L802 are connected to the Y deflection plates of the c.r.t. The Y deflection plates form filters together with the coils L801 and L802.

These filters terminate in resistors R859, R861, R862 and R863.

The output signals from the TRACE SEPARATION circuit are applied via the resistors R864 and R866 of the Y final amplifier.

2.3. MAIN TIME-BASE TRIGGERING

The trigger source switches for triggering the main time-base generator, can select any of the following input sources:

- an internal signal from the vertical A channel
- an internal signal from the vertical B channel
- an internal composite signal of channel A and channel B
- a signal derived from the mains supply
- an external source
- an external source divided by 10

All these sources can be used for both triggering and X deflection purposes. Source selection is done by means of a trigger selector switch S22 that feeds the trigger signals to the trigger amplifier.

2.3.1. Main time-base trigger source selection and preamplifier

The signal currents ($60 \mu\text{A}/\text{div.}$) of the three trigger pick-off stages are, after selection by S22C and S22D, amplified to a level of $100 \text{ mV}/\text{div.}$ by a shunt feed-back stage + emitter follower stage consisting of V351 and V352. After this stage there is a selection between its output signal, a signal on the external socket and a signal with the line frequency by means of S22A and S22B. Signals that are not used are short-circuited to mass.

The externally applied signal is attenuated by factor of two or twenty (depending on position of EXT and $\text{EXT} \div 10$) to achieve an input sensitivity of $200 \text{ mV}/\text{div.}$

2.3.2. Impedance converter and trigger comparator

The trigger signal of $100 \text{ mV}/\text{div.}$ is fed via the AC-DC coupling circuit to a FET (V1006) in source follower configuration.

From here the signal is applied via an emitter follower and a common emitter amplifier D1001 (123/345) to the \pm slope selection circuit. The selection switch S8 enables triggering on either the positive-going or the negative going edge of the triggering signal.

From the \pm slope selector circuit, the signal is fed to the output shunt feed-back amplifier V1026 via the switches TVL mode (AC + AUTO) and TVF mode (AUTO + DC). The voltage gain is high (28x) but its dynamic range is small ($2,8 \text{ V}_{\text{p-p}}$ at the output). This is because of the tail current of the symmetrical common emitter stage is 2 mA. The current sweep at the output of this stage is consequently 2 mA at max. which is transformed into a $2,8 \text{ V}$ max. voltage sweep at the output of the shunt feed-back amplifier V1026. This means that the trigger amplifier is completely driven at a trace height of 1 div. Which division on the screen this is, depends on the position of the LEVEL control R7.

With AC (S4A) or DC (S4C) depressed, the range of the LEVEL control is fixed. The DC voltage at the wiper of LEVEL control R7, which is fed to the FET (V1006) can vary between +2,8 V and -2,8 V. Diodes V1001 and V1002 are then turned-off, and the voltage on the gate of the FET is then adjustable between +0,86 V and -0,86 V. At a signal level on the gate of the other FET of 100 mV/div., there will be a control range of $\pm 8,6$ divisions.

2.3.3. Peak to peak level detector

If the AUTO push-button S4B is depressed, the supply voltages for the level control circuit are interrupted. A trigger signal (300 mV/div.) which is derived from the emitter follower stage and amplified by V1007, gives after peak to peak detection a DC voltage across the level control. This DC voltage is approx. proportional to the amplitude of the trigger signal. This is the auto trigger level control. The peak to peak level of the signal then determines the range of the level control.

2.3.4. T.V. Synchronisation separator

If the TVL mode of the TVF mode is selected, the LEVEL control is switched off. The wiper of R7 is then connected to mass. A synchronisation separator for the television signals is then inserted into the trigger signal path.

A composite video signal contains, besides the video information, also synchronisation pulses with line and frame frequency which can be distinguished by their pulse width.

The TV synchronisation separator circuit is able to:

1. separate the synchronisation pulses from the video information.
2. distinguish between frame synchronisation pulses and line synchronisation pulses.

The first requirement is met by V1024, acting as a DC restorer and limiter, the second requirement by the integrating network R1044, C1009 and C1011.

The TV signal is picked-off from the emitter follower D1001 (678/91011) and fed to the \pm slope selection circuit. The \pm slope selector switch S8 can be set for the right polarity of the TV signal. The TV trigger signal is then amplified by the series feed-back push-pull stage V1008, V1009 and applied to synchronisation separator V1024 via emitter follower V1023.

The signal on the base of V1024 could be as follows:

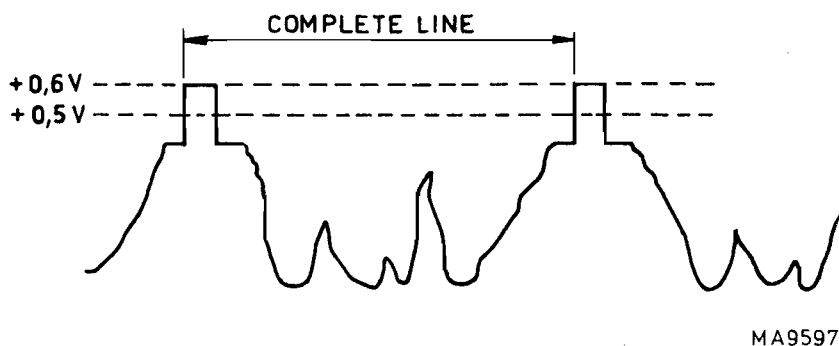

Fig. 2.3. Signal on the base of transistor V1024

The peaks of the synchronisation pulses are all at one level by the DC restorer action of C1007, R1042 and the base emitter diode of V1024. The base voltage will never exceed +0,6 V by a large amount, but the complete waveform will appear at the base. The signal level is at this point approx. 280 mV per screen division. Change in signal of approx. 100 mV is sufficient to turn off V1024. V1024 looks only to the peaks of the synchronisation pulses.

The rest of the TV signal has no influence. On the collector of V1024 we find only the synchronisation signal consisting of line synchronisation pulses and the wider frame synchronisation pulses.

In the TVL mode (push-buttons AC and AUTO depressed), this complete signal is transmitted to the time-base generator and we have line triggering.

In the TVF mode (push-buttons AUTO and DC depressed), C1009 and C1011 are connected to mass. The narrower line synchronisation pulses are then integrated out of the signal, but the wider frame synchronisation pulses remain and frame triggering is obtained. A second threshold is built-up by V1027.

V1028 reacts to the signal that still passes and consists of pure line or frame synchronisation pulses. After this the signal is fed to the time base generator via V1026.

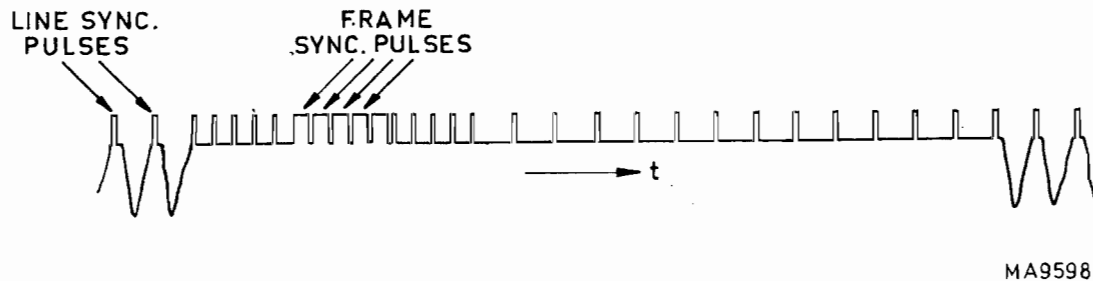

Fig. 2.4. A vertical interval with frame synchronisation pulse group.

2.4. MAIN TIME-BASE GENERATOR

The main time-base generator comprises a sweep gating logic, a sweep generator, a hold-off circuit and an auto sweep circuit.

Before considering these stages in detail, the general principle is briefly described. Basically, the sweep gating logic, under the control of trigger signals from the trigger comparator and also feedback pulses from the hold-off circuit, supplies square-wave pulses to the switching transistor V1208 of the sawtooth generator.

The time-base capacitors (effectively in parallel with the switching transistor) are charged linearly through a constant-current source to provide the forward sweep, and are discharged rapidly by the switching transistor to provide the flyback period. The resulting sawtooth is fed via the X deflection selector to the X final amplifier.

2.4.1. Main time-base sweep generator

The sweep speed or time coefficient is determined by the value of the time-base capacitance in circuit, and also by the magnitude of the charging resistor selected.

The time-base capacitors are C1203 and C1206. Capacitor C1203 is always in circuit, the other one is selected by the transistor V1212. This transistor operates as an electronic switch and is either fully cut-off or fully conducting. It is switched on by the application of a positive voltage to its base from the TIME/DIV switch S15.

According to the position of S15, this transistor V1212 switches in the capacitor C1206 in parallel with C1203. As mentioned, the sweep speed is also dependent upon the magnitude of the accurate constant-current supplied by transistor V1209. This current can be adjusted in steps by selecting the emitter resistance of V1209 by means of the TIME/DIV switch S15. Continuous control of the charging current can be effected by varying the base drive to V1209 with the continuous sweep control, TIME/DIV potentiometer R12. In the CAL position of this potentiometer, switch S16 closes and the charging current is solely determined by the calibrated emitter resistance.

To compensate for the temperature coefficient of the transistor, the base voltage of V1209 is supplied via transistor V1214. This also has the advantage of reducing the load on the TIME/DIV potentiometer R12. This transistor, in turn, has its base controlled by preset potentiometer R1216 when TIME/DIV switch S15 is in one of the positions 0,5 s/div ... 0,5 ms/div. This provides an adjustment for the timing circuit in the slower sweep speeds. In these positions the preset potentiometer R1216 provides an additional measure of control over the base voltage of V1209. In the positions of S15 when C1206 is not in circuit, the diode V1217 is blocked and the preset control R1216 is inoperative.

The discharge circuit for the capacitors C1203 and C1206 consists of resistor R1210 and transistor V1208.

This switching transistor is driven by the sweep gating logic.

Transistor V1207, the other switching transistor, short-circuits the charging current to earth when the time-base capacitors are being discharged. This means that the voltage across C1203 and C1206 is independent of the charging current at the moment that the sweep starts. Both switching transistors are driven with the same control signal, supplied by the sweep gating multivibrator.

The resulting sawtooth voltage is taken from two transistors V1218 and V1221 in a Darlington configuration. C1208 improves the transfer of faster sawtooth signals at the expense of the input impedance which need not to be that high then. The sawtooth voltage amplitude is approx. 5 V. This sawtooth voltage is then fed via the X deflection selector to the X final amplifier.

2.4.2. Main time-base hold-off circuit

The hold-off circuit prevents the sweep gating logic from responding to trigger pulses before the time-base capacitor has fully discharged. The sawtooth output from the Darlington pair V1218 and V1221 is applied to the base of emitter follower V1219.

The switching transistor V1213 switches the hold-off capacitor C1207 in circuit, parallel to C1204 according to the position of the TIME/DIV switch S15, in a similar manner to that described for the time-base integrator timing capacitor. Capacitor C1204 is always in circuit irrespective of the TIME/DIV switch position.

Charging current for the hold-off capacitors follows via transistor V1219. When V1219 cuts off the discharge current flows through R1221 and R16. This discharge current is adjustable to vary the hold-off time.

The voltage across hold-off capacitor C1204 or C1204 + C1207 follows the sawtooth voltage fairly fast in positive going direction via emitter follower V1219. When a certain value is reached, integrated Schmitt-trigger D1201 reacts and the end of the sweep is initiated.

This is followed by a hold-off period in which the voltage across the hold-off capacitor decreases fairly slowly until the lower switching level of the Schmitt-trigger is reached. The system can now be triggered again. In the mean-time also the time-base integrator timing capacitor C1203 or C1203 + C1206 has reached its quiescent state. The output (point 3) of D1201 is low during the hold-off time, at any other moment this output is high.

2.4.3. Main time-base sweep gating logic

The main time-base sweep gating logic which consists of TTL logic circuits is controlled by the following signals:

- The trigger signals supplied by the trigger comparator.
- The voltage supplied by the hold-off circuit.
- The voltage supplied by the auto circuit.

The TTL circuit D1201 contains 2-input NAND-gates with Schmitt-trigger properties. D1202 is a retriggerable monostable multivibrator. D1203 contains two D-type flip-flops and D1204 contains normal 2-input NAND-gates.

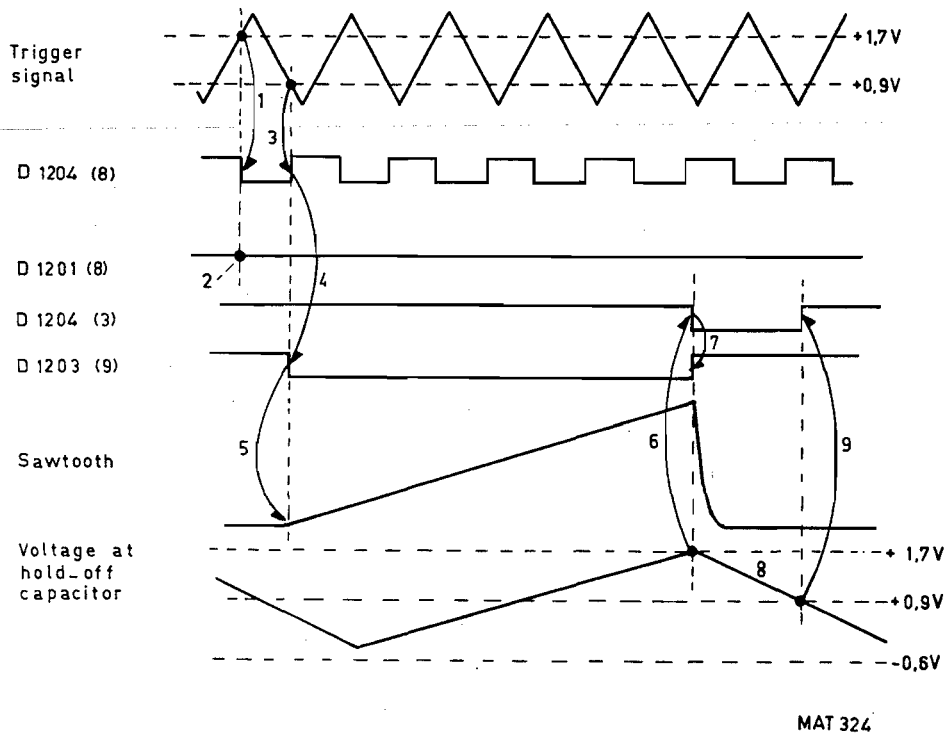

Fig. 2.5. The relation diagram of the main time-base sweep-gating logic in the AC or DC mode.

See for the following explanation time relation diagram Fig. 2.5.

1. The incoming trigger signal from the trigger comparator switches the Schmitt-trigger output (D1204 point 8) to zero after a positive going edge has exceeded the upper switching level (+1,7V) of this Schmitt-trigger.
2. The Schmitt-trigger output (D1201, point 8) is at logic 1 state, while input 10 of this Schmitt-trigger is connected to logic 0 via the switches S4B (AUTO) and S4A (AC) or S4C (DC).
3. If the negative going edge of the incoming trigger signal drops below the lower switching level (+0,9V) of the Schmitt-trigger, the output (D1204 point 8) switches to logic 1 level again.
4. After this, the D-type flip-flop output (D1203, point 9) is set to the logic 0-state by the trigger signal on its clock input.
5. The output signal of this flip-flop is applied via D1201, gates 12 and 6 to switching transistors V1207 and V1208 and causes the sweep to start.
6. The end of the sweep is reached when the signal across the hold-off capacitors C1204 and C1207 exceeds the upper switching level (+1,7V) of the hold-off Schmitt-trigger. The output (D1204, point 3) of this Schmitt-trigger switches then to logic 0 level.
7. The D-type flip-flop is now reset. Switching transistors V1207 and V1208 start conducting and the time-base capacitors C1203 and C1206 will discharge.
8. The voltage across the hold-off capacitors C1204 and C1207 decreases slowly until the lower switching level (+0,9V) of the Schmitt-trigger is reached. The hold-off time is variable by the HOLD-OFF control.
9. This is the end of the hold-off period. The output (D1204, point 3) of the hold-off Schmitt-trigger rises to 1 again and the system can be triggered again.

2.4.4. Auto sweep circuit

In the absence of a trigger signal we would still like to see a display on the screen. The auto sweep circuit serves this purpose.

The oscilloscope can be set in AUTO free run mode by pushing the AUTO push-button of the MTB trigger mode selector switch.

In the absence of a trigger signal, the output of the retriggerable monostable multivibrator (D1202, point 6) remains at logical 1-level. On the Schmitt-trigger output (D1201, point 8) appears the inverted signal of D1204, point 3 because input 9 is set to logic 1 via R1201 (S4A, S4B and S4C are open).

The hold-off signal on point 3 of D1204, now can reach the switching transistors V1207 and V1208 via D1201 (8,12, 6) and the loop is then closed and the time-base generator is in the free-running mode.

If D1204 (3) is low (sweep is running), a trigger signal appears at the output of the Schmitt-trigger D1204 (8) and when the oscilloscope is set in AUTO mode, the output point 9 of the D-flip flop D1203 will be set to logical 0-level.

Then output 6 of the retriggerable monostable multivibrator will be set to logical 0 and the circuit works as in the normal trigger mode.

2.5. DELAYED TIME-BASE TRIGGERING

The trigger source switches for triggering the delayed time-base generator, can select any of the following input sources:

- an internal signal from the vertical A channel.
- an internal signal from the vertical B channel.
- an internal composite signal of channel A and channel B.
- an internal triggering signal derived from the main time-base to start the delayed time-base immediately after the selected delay time.

Source selection is done by means of a trigger selector switch S21 that feeds the trigger signals to the trigger amplifier.

2.5.1. Delayed time-base trigger source selection and preamplifier

The signal currents ($60 \mu\text{A}/\text{div.}$) of the three trigger pick-off stages are, after selection by S21C and S21D, amplified to a level of $150 \text{ mV}/\text{div.}$ by a shunt feed-back stage + emitter follower stage consisting of V451, V452 and V453. After this stage there is a selection between its output signal and a signal on the external socket by means of S21B.

Signals that are not used are short-circuited to mass.

The externally applied signal is attenuated by a factor of two allowing standardisation of the input impedance of the EXT socket to $1 \text{ M}\Omega // 20 \text{ pF}$.

2.5.2. Impedance convertor and trigger comparator

The trigger signal of $150 \text{ mV}/\text{div.}$ is fed via the AC-DC coupling circuit to a FET (V1102) in source follower configuration.

From here the signal is applied via an emitter follower and a common emitter amplifier D1101 (123/345) to the \pm slope selection circuit.

The selection switch S6 enables triggering on either the positive-going or the negative-going edge of the triggering signal.

From the \pm slope selector circuit, the signal is fed to the output shunt feed-back amplifier V1109.

The range of the LEVEL control is fixed. The DC voltage at the wiper of LEVEL control R5, which is fed to the FET (V1102) can vary between $+12 \text{ V}$ and -12 V . The voltage on the gate of the FET is then adjustable between $+1,3 \text{ V}$ and $-1,3 \text{ V}$. At a signal level on the gate of the other FET of $150 \text{ mV}/\text{div.}$ there will be a control range of $\pm 9 \text{ div.}$

2.6. DELAYED TIME-BASE GENERATOR

The delayed time-base generator comprises a sweep gating logic, a sweep generator and an end of the sweep-detector.

Before considering these stages in detail, the general principle is briefly described.

Basically, the sweep gating logic, under the control of trigger signals from the trigger comparator and also feed-back pulses from the hold-off circuit, supplies square-wave pulses to the switching transistor V1314 of the sawtooth generator. The time-base capacitors (effectively in parallel with the switching transistor) are charged linearly through a constant-current source to provide the forward sweep, and are discharged rapidly by the switching transistor to provide the flyback period. The resulting sawtooth is fed via the X-deflection selector to the X-final amplifier.

2.6.1. Delayed time-base sweep generator

The sweep speed or time coefficient is determined by the value of the time-base capacitance in circuit, and also by the magnitude of the charging resistor selected.

The time-base capacitors are C1302 and C1303. Capacitor C1302 is always in circuit, the other one is selected by the transistor V1319. This transistor operates as an electronic switch and is either fully cut-off or fully-conducting. It is switched on by the application of a positive voltage to its base from the TIME/DIV switch S13. According to the position of S13, this transistor V1319 switches in the capacitor C1303 in parallel with C1302.

As mentioned, the sweep speed is also dependent upon the magnitude of the accurate constant-current supplied by transistor V1316. This current can be adjusted in steps by selecting the emitter resistance of V1316 by means of the TIME/DIV switch S13. Continuous control of the charging current can be effected by varying the base drive to V1316 with the continuous sweep control, TIME/DIV potentiometer R11.

In the CAL position of this potentiometer, switch S14 closes and the charging current is solely determined by the calibrated emitter resistance.

To compensate for the temperature coefficient of the transistor, the base voltage of V1316 is supplied via transistor V1318. This has also the advantage of reducing the load on the TIME/DIV potentiometer R11. This transistor, in turn, has its base controlled by preset potentiometer R1336 and by preset potentiometer R1344 only when TIME/DIV switch S13 is in one of the positions 20 μ s/div. ... 1 ms/div. Potentiometer R1336 enables the sweep speeds of the delayed time-base generator to be equalized to those of the main time-base generator. This provides a fine adjustment for the timing circuit in the slower sweep speeds.

In these positions the preset potentiometer R1344 provides an additional measure of control over the base voltage of V1316.

In the positions of S13 when C1303 is not in circuit, the diode V1326 is blocked and the preset control R1344 is inoperative.

The discharge circuit for the capacitors C1302 and C1303 consists of resistor R1328 and transistor V1314. This switching transistor is driven by the sweep gating logic.

The resulting sawtooth voltage is taken from two transistors V1321 and V1322 in a Darlington configuration. C1304 improves the transfer of faster sawtooth signals at the expense of the input impedance which need not to be that high then. The sawtooth voltage amplitude is approx. +5 V. This sawtooth voltage is then fed via the X-deflection selector to the X-final amplifier.

2.6.2. Delayed time-base end of the sweep detector circuit

This circuit prevents the sweep gating logic from responding to trigger pulses before the time-base capacitor has fully discharged. The sawtooth output from the Darlington V1321 and V1322 is applied to the base of emitter-follower V1324.

When the emitter of the emitter-follower V1324 has reached a certain value, integrated Schmitt-trigger D1301 reacts and the end of the sweep is initiated.

This is followed by a period in which the sawtooth voltage decreases until the lower switching level of the Schmitt-trigger is reached. The flip-flop formed by the two NAND-gates can now be reset by the signal from point 8 of NAND D1301 (8-9-10) i.e. at the end of the main time-base gate.

During one sweep of the main time-base only one sweep of the delayed time-base can be generated.

The DTB sweep is always reset at the end of the main time-base sweep via the main time-base gate signal.

The system can now be triggered again.

2.6.3. Delay time function

The function of the DELAY TIME potentiometer R4 is to provide an adjustable d.c. voltage for comparison with the sweep voltage of the main time-base generator. This comparison is then used to start the delayed time-base generator at a pre-determined time during the sweep of the main time-base. The DELAY-TIME potentiometer R4 is a 10-turn front-panel control.

2.6.4. Comparator circuit

The comparator comprises the transistors V1302, V1303 and V1304. V1303 is a constant-current source for V1302 and V1304.

The d.c. voltage set by the DELAY TIME potentiometer R4 is fed to the base of the left hand transistor V1304 via the emitter followers V1307 and V1306. The sawtooth voltage of the main time-base generator is fed to the right-hand transistor V1302. As soon as the amplitude of the sawtooth exceeds the set d.c. voltage, the collector voltage of the right-hand transistor V1302 drops. This voltage drop is, fed via inverter V1301 to the delayed time-base sweep gating logic. The circuit is switched off in the OFF position of the DTB TIME/DIV switch S13 by interrupting the +12 V supply to R1305.

2.6.5. Delayed time-base sweep gating logic

The delayed time-base sweep gating logic which consists of TTL logic circuits is controlled by the following circuits:

The TTL circuit D1301 contains 2 - input NAND-gates with Schmitt-trigger properties. D1204 and D1302 contain normal 2-input NAND-gates and D1203 contains two D-type flip-flops.

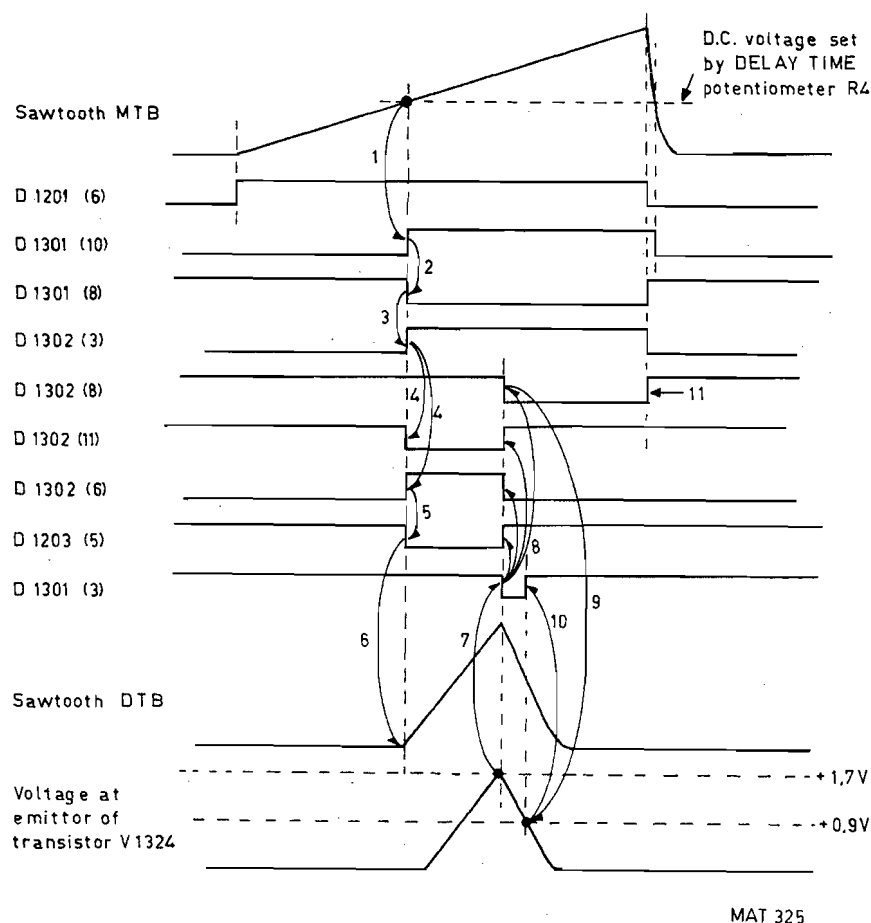

Fig. 2.6. Time relation diagram of the delayed time-base sweep gating logic in the MTB trigger mode.

Relating to the numerical sequence of Fig. 2.6.:

1. Comparing the main time-base sawtooth signal with the d.c. voltage set by the DELAY TIME potentiometer R4 results in a positive going signal at the input 10 of Schmitt-trigger D1301.
2. Only during a main time-base sweep, the main time-base gate at the input 9 of Schmitt-trigger D1301 will be at logical 1 level. The output (point 8) of this Schmitt-trigger will go to logical 0 level on the positive-going edge of the comparator output signal.
3. The output signal of the Schmitt-trigger is inverted in NAND-gate D1302 (output 3).
4. Assume that output 8 of the flip-flop formed by the two NAND-gates is at logical 1 level. Then the output 11 of D1302 will go to logical 0 level and the input 4 of D-type flip-flop D1203 to logical 1 level.
5. The switches S21B, S21C and S21D are closed in the MTB trigger mode and input 1 of D - type flip-flop D1203 is set to logical 0 level. In this situation the D - type flip-flop part between input 4 and output 5 will act as an inverter.
6. Output 5 of D1203 will go to zero level and this signal is applied to switching transistor V1314 and causes the sweep to start.
7. The end of the sweep is reached when the signal at the emitter of transistor V1324 exceeds the upper switching level (+1,7 V) of the hold-off Schmitt-trigger. The output (D1301, point 3) of this Schmitt-trigger switches then to logic 0 level.
8. The output of the flip-flop formed by the two NAND-gates is now set to 0 level.
9. The voltage at the emitter of transistor V1324 decreases slowly until the lower switching level (+0,9 V) of the Schmitt-trigger is reached.
10. This is the end of the hold-off period. The output (D1301, point 3) of the hold-off Schmitt-trigger rises to 1 again.
11. At the end of the main time-base sweep, the output 8 of the flip-flop formed by the two NAND-gates is switched to logical 1 level and the system can be triggered again.

A, B or EXT triggering

If one of the DTB trigger source selector switches A, B or EXT is selected, the level at input 1 of the D-type flip-flop D1203 will go to logical 1 level.

The D-type flip-flop can now only be set to zero by means of a trigger signal from the delayed time-base trigger comparator which is applied to the clockpulse input of the flip-flop.

2.7. X DEFLECTION SELECTOR AND ALTERNATE TIME-BASE LOGIC

Depending on the selected position of X deflection source selector switch S3, the circuit provides for X deflection by the main time-base signal, the delayed time-base signal, a signal from an external source or X deflection by one of the internal signals derived from channel A, channel B or the mains voltage.

The source selector is described according to the selected mode.

- MTB — In this position of the switch S3, the +12 V supply is routed via the contacts of S3A and via diode V1651 to the base of transistor V1658 which results in a collector voltage of $-1,7$ V. This voltage is routed to the junction of the two diodes V1401 and V1404, the diodes are blocked and there is no signal path for the delayed time-base output sawtooth signal to the X final amplifier.
- At the same time the other transistor (V1659) of the alternate flip-flop is conducting and its collector voltage is about +10,5 V. This voltage is applied to the junction of the diodes V1403 and V1412, these diodes conduct and provide a path for the output sawtooth signal of the main time-base to the X final amplifier.
- This means that only the main time-base sawtooth signal is fed to the X final amplifier and not the delayed time-base sawtooth signal and the X deflection signal.

- DTB**
- In this position of the switch S3, the +12 V supply is routed via the contacts of S3A and S3B and via diode V1653 to the base of transistor V1659. This results in a voltage of $-1,7$ V at the collector of V1659 and a voltage of $+10,5$ V at the collector of V1658. The diodes V1403 and V1412 are blocked and there is no signal path for the main time-base output sawtooth signal to the X-final amplifier.
A signal path is now provided via the diodes V1401 and V1404 for the delayed time-base output sawtooth signal.
With DTB selected the main time-base signal and the X deflection signal are blocked.
- X DEFL**
- In the position X DEFL of the switch S3 +12 V voltages are fed to the bases of the transistors V1658 and V1659. Both collector voltages are at a level of $-3,9$ V and the diodes V1401, V1404, V1403 and V1412 are blocked. The signal paths for the main time-base sawtooth signal as well as for the delayed time-base sawtooth signal are blocked.
At the same time the constant-current source V1011 in the main time-base trigger circuit is blocked and no trigger signals are fed to the sweep gating logic.
In the sweep gating logic there is a 0 V signal applied to the input 10 of D1204 and as result a 0 V is fed to the Z-amplifier. This means that the trace will be totally unblanked.
The X deflection signals are transmitted to the X final amplifier via transistor V1409 as described in the description of the X final amplifier.
- ALT TB**
- With both push-buttons S3A and S3B depressed, the oscilloscope is set in the alternate time-base mode and the main and delayed time-bases are selected alternately.
In this mode there is no +12 V applied to the bases of the transistors V1658 and V1659, the alternate circuit is bi-stable and one of the diodes V1654 and V1656 is conductive. MTB-gate pulses derived from the main time-base generator are fed to the junction of the diodes V1654 and V1656 to switch the circuit at the end of each main time-base sweep and the main and delayed time-base are alternately selected.
The collector signal of transistor V1658 is fed to the junction of diodes V1401 and V1404 to block or open the DTB signal path and the collector signal of transistor V1659 is fed to the junction of diodes V1403 and V1412 to block or open the MTB signal path.
These collector signals are also applied to the trace separation circuit which allow an adjustable trace separation potential to be alternatively applied to the two paths of the vertical final amplifier depending on whether MTB or DTB is selected by the alternate flip-flop. Trace separation is adjustable by front-panel control R14. The trace separation potentials are routed from the collector of V1664 via R864 and from the collector of V1666 via R866 to the vertical final amplifier.
The generation of switching pulses for the channel multivibrator depends on the selection of ALT and ALT TB.
 - With ALT TB not selected and ALT selected, negative going pulses derived from the main time-base gate are routed directly from R1653 to the channel multivibrator to switch the A and B channel alternately.
 - With ALT TB selected and ALT mode not selected the signal path from R1653 to the channel multivibrator is blocked by a +12 V signal which is applied via switch S3B to R1671.

Transistor V1668 is conducting if ALT is not selected because a 0 V signal is fed to R1686 via R708 and the alternate signals from the switching of the alternate flip-flop are blocked.
 - With ALT TB as well as ALT selected the signal path from R1653 to the channel multivibrator is blocked by a +12 V signal which is applied via switch S3B to R1671.
Transistor V1668 is conducting now because a -12 V signal is fed to its base via S1A, S1C, S1D, S1E and R1686. Negative going alternate pulses derived from the alternate time-base logic are fed to the channel multivibrator. These pulses appear at the end of every two sweeps of the main time-base.

2.8. X FINAL AMPLIFIER

Transistor V1414 is driven by the main time-base generator via diodes V1403 and V1412 when R1408 is kept at +12 V level, or by the delayed time-base generator via diodes V1401 and V1404 when V1406 is kept at +12 V level or the amplifier stage V1409 when R1409 is kept at +12 V level via the X deflection mode selector switch S3C (X DEFL).

Transistor V1409 receives its input signal from D1001 point 8 of the trigger amplifier. This signal is derived from one of the sources, channel A, channel B, line or an external source, depending on the setting of the X deflection selector switch S22.

The final X amplifier consists of two amplifier stages in parallel (one for each deflection plate). Only one half is described.

The actual amplifier is the cascode circuit with transistors V1418 and V1419. The resistors R1429 and R1431 are feedback resistors. The bias current for the amplifier is supplied by transistor V1417. The average voltage on the deflection plate is kept at +26 V by means of zener diodes V1427 and V1428. Capacitor C1413 improves the h.f. response.

The final stage is supplied from the +180 V and -180 V because the X plates of the C.R.T. are mechanically displaced such that they are less sensitive than the Y plates.

The cascode amplifier stages are controlled via the transistors V1413 and V1414.

The bias of transistor V1413 can be varied with the X POSITION potentiometer R6, which consists of a tandem potentiometer with back-lash, giving a nice vernier control. Variation of the bias causes the balance of the amplifier to be disturbed, which results in a horizontal trace shift on the screen.

The X amplifier allows choice from X deflection by the time-base signals or one of the sources, channel A, channel B, line or an external signal. The deflection source is selected with the aid of X deflection mode selector switch S3 and the X deflection source selector switch S22.

The X amplifier offers the possibility of using either the nominal gain (x1 position of XMAGN switch S7), or the gain increased by a factor of 10 (x10 position of the XMAGN switch S7).

When the front-panel XMAGN switch is operated for x10 magnification, the emitter resistance R1416 + R1417 of transistors V1413 and V1414 is shunted by resistors R1418 + R1419 reducing the value by a factor of 10. Consequently, the gain of the stage is increased by the same factor.

The x1 gain can be set by potentiometer R1417 and the x10 gain by potentiometer R1419. The x10 gain is also operative when XDEFL is selected.

Both outputs of the X final amplifier are connected to the X deflection plates of the C.R.T.

2.9. CATHODE-RAY TUBE CIRCUIT

The cathode-ray tube circuit consist of the c.r.t. and its associated controls: focus, trace rotation and the beam blanking amplifier.

2.9.1. C.R.T. controls

By means of the INTENS potentiometer R1, the brightness of the display can be continuously controlled. The display can be focused by means of the FOCUS potentiometer R8. Both INTENS and FOCUS controls are front panel controls.

Furthermore the C.R.T. circuitry comprises preset potentiometers for trace rotation, astigmatism and geometry.

The FOCUS control R8 forms a part of a voltage divider network across the 1,5 kV output of the power supply. The slider of this potentiometer is connected direct to the focus, grid G3.

TRACE ROTATION is achieved by means of the trace rotation coil L1501. This coil mounted inside the mu-metal screen, provides a magnetic field for rotational control of the entire scan. The degree and direction of rotation is determined by the setting of front panel potentiometer R13 (screwdriver operated). The slider of R13 is connected to the bases of the complementary transistors V1527 and V1528. The trace rotation coil L1501 is supplied by these transistors.

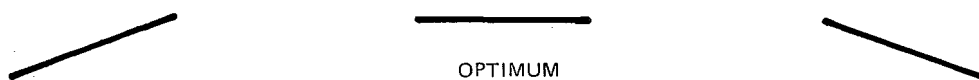

With the ASTIGMATISM control R1543, the form of the spot can be adjusted by influencing the voltage on the grids G2 and G4.



With the GEOMETRY control R1549 the barrel and pin-cushion distortion is corrected by influencing the voltage on the grid G7.

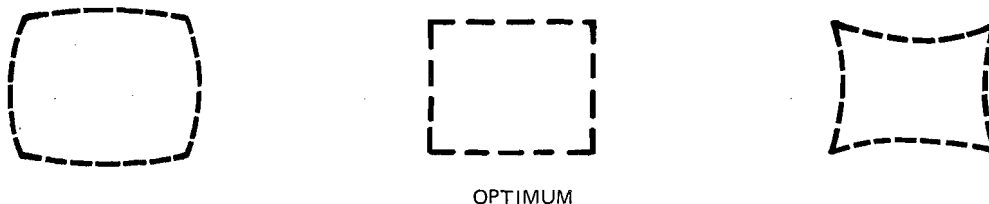

MA9595

2.9.2. Beam blanking amplifier

The beam blanking amplifier receives three input signals.

Two signals originate in the main and delayed time-bases and are applied to the amplifier to unblank the trace during the sweeps. The third one is supplied by the channel multivibrator to blank the trace during switching from channel to channel in the chopped mode.

The INTENS potentiometer R1 determines the amount of input current fed to the amplifier.

In all the X deflection modes with the exception of XDEFL, input 10 of NAND-gate D1204 is kept at +5 V. The output point 8 of this NAND is now at logic 1-level when input 9 is low. In other words only during a sweep.

In the XDEFL position of the X deflection mode selector switch S3, input 10 of NAND D1204 is at a logic 0 level, and in that case the output point 8 of this NAND is steady at logic 1 level. This output signal (the MTB unblanking signal) is inverted by a NAND and fed via diode V1502 to diode V1512 of the beam unblanking amplifier.

The DTB unblanking signal is taken off from D-type flip-flop D1203 point 5 and fed via diode V1308 and V1503 to diode V1512 of the beam unblanking amplifier.

The chopped mode blanking signal from the channel multivibrator is fed to transistor V1511 via R1501. The inverted and amplified signal is applied to diode V1508.

MTB selected — With the TIME/DIV switch S13 of the delayed time-base in the "OFF" position, only the MTB unblanking pulse is fed to the shunt feed-back amplifier and a bright main time-base trace is displayed on the screen.

- With the TIME/DIV switch S13 of the delayed time-base operative; i.e. not in the "OFF" position, R1508 is connected to the +12 V and a current flows through brilliance ratio potentiometer R1507. During the part of the sweep where only the main time-base is running, a part of the MTB current (controlled by R1507) flows into the Z-amplifier; i.e. the trace is less bright. During the delayed time-base gate there will flow more current into the Z-amplifier and the trace is then intensified as long as the delayed time-base is running. The ratio between the intensified and the non-intensified part is constant for high and low intensity.

High intensity

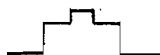

Low intensity



DTB selected

- If the delayed time-base is selected, the MTB unblanking pulse is suppressed and only the DTB unblanking pulse is fed to the shunt feed-back amplifier. The trace will be unblanked during the delayed time-base sweep.

All the signals are joined together at the base of transistor V1521 point A in figure 2.7. . This is the virtual earth point of the shunt feed-back amplifier.

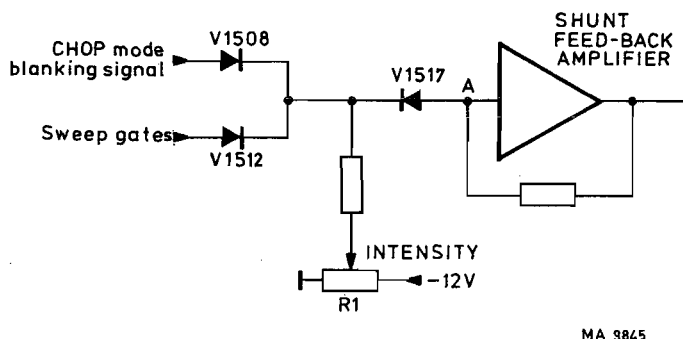

Fig. 2.7. Shunt feed-back amplifier.

Assume that V1508 and V1512 are turned-off by applying a logic zero to both inputs. Then the output voltage of the amplifier can be varied with the aid of INTENS potentiometer R1. The light on the screen is variable then e.g. during a main and/or delayed sweep or in the X deflection mode. A logic 1 on either one or both inputs of the diodes V1508 and V1512 turns V1517 off. The C.R.T. is then blank e.g. between sweeps or during the sweep when there is channel switching in the chop mode.

The blanking signal is amplified in the stage with transistors V1518, V1519 and V1521. At the output of this amplifier the a.c. and d.c. components of the blanking signal are guided along different paths. The a.c. path runs straight to the Wehnelt cylinder of the C.R.T. via capacitor C1511.

A d.c. signal is fed to the emitter of transistor V1523 via a low-pass filter R1531/C1507/R1529. Transistor V1523 constitutes a multivibrator together with transistor V1522. The a.c. voltage on the collector of V1523 has a peak-to-peak value which depends on the voltage fed to the emitter of V1522 by the shunt feed-back amplifier.

The a.c. voltage supplied by multivibrator V1522/V1523 is applied to a peak detector. This peak detector rectifies this a.c. voltage.

The reason for the a.c. and d.c. paths is isolation of the cathode and Wehnelt cylinder, which are on a -1.5 kV potential, from the other circuits. The a.c. component of the blanking signal is transmitted straight away to the high-voltage part via blocking capacitor C1511, which is a high voltage capacitor. The d.c. signal, however, is converted into an a.c. voltage and then transmitted to the high-voltage part, via capacitor C1508, after which it is rectified by means of diode V1526. The dark level can be adjusted with the aid of potentiometer R1537 in the emitter circuit of transistor V1523 in the d.c. amplifier.

2.10. POWER SUPPLY

2.10.1. General

The power supply is designed on the switching regulator principle and permits the instrument to be connected to nominal voltages of 110V, 127V, 220V or 240V by switch selection, or an external battery supply of 22 ... 27V.

The mains supply via POWER ON switch S23 is protected by fuse F202. The battery input is protected by fuse F201 and diode V206 safe-guards the circuit against reversed battery connection.

Basically, the power supply consists of:

- Mains transformer
- Converter and stabilized power supply
- Illumination circuit

2.10.1. Mains transformer

An incoming mains voltage is fed via the thermal fuse (F101) and the voltage selector S24 to the appropriate primary taps on the mains transformer T101. Transformer T101 has three primary windings which can be combined by means of voltage adapter S24. This combination allows the instrument to be used with mains voltages of 110 V, 127 V, 220 V and 240 V.

The voltage on the secondary windings of this transformer is full-wave rectified. The resulting negative d.c. voltage (approx. 24V) across electrolytic capacitor C203, or alternatively a negative battery voltage on the rear panel DC POWER IN input socket X7, is applied to the voltage stabilizer and converter.

Part of the a.c. voltage on the secondary winding of the mains transformer is fed via C201, R368 and R367 to LINE trigger source selector switch S22A, to enable internal triggering on the line frequency.

2.10.2. Converter and stabilized power supply

The converter is a square-wave generator operating at a frequency of approx. 18 kHz and driven by the d.c. voltage across the electrolytic capacitor C203.

A basic diagram of the converter is shown in figure 2.8.

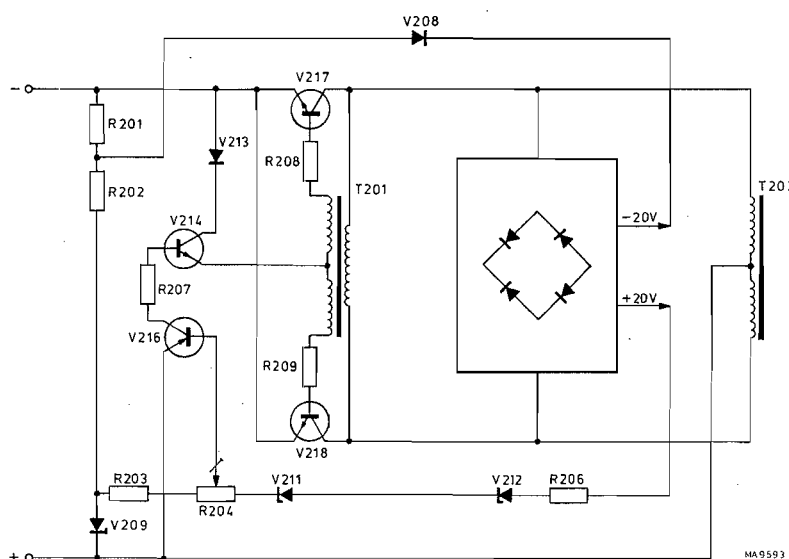

Fig. 2.8. Basic diagram of the converter.

In the converter, transistors V217 and V218 function as switches and regulators and alternately connect the negative supply voltage to either end of the primary of T201/T202. Assume that transistor V217 has a slightly higher current gain than V218. Then the positive voltage from the feed-back winding quickly drives transistor V217 into saturation. The current in the top half of the primary of T201/T202 increases linearly at a rate determined by the inductance of the primary. This current increase continues until the iron in transformer coil T201 is saturated.

Then the magnetic lines of flux stop changing and consequently no voltage is induced any longer in the feed-back winding. When its base drive ceases, the transistor is cut off. This reverses the polarity of the feed-back voltage and transistor V218 is turned hard on. The bottom half of the primary then passes an increasing current until the core is saturated in the opposite direction.

The subsequent absence of feed-back voltage initiates the switching back to V217 and the cycle starts again.

The regulation works as follows. When input voltage is applied to the converter, the negative voltage across Zener diode V209 turns transistor V216 fully on, as there is no positive voltage from temperature compensation stabistors V211 and V212. Then a bias current flows via transistor V216 through resistor R207, through the base-emitter junction of transistor V214 (operating as a diode since diode V213 interrupts the collector circuit) and from base to emitter of both transistors V217 and V218.

As there is then an a.c. voltage across the primary of T201/T202, diodes V222 and V223 produce a positive d.c. voltage of +20 V across capacitor C209. This voltage reduces the current through transistors V216 and V214 sufficiently to limit the drive to transistors V217 and V218 and produces the desired output level.

The setting of potentiometer R204 determines the value of the regulated output voltage. Possible differences from the set output voltage are fed back via the temperature compensation stabistors V211 and V212 to transistor V216 so that the drive of transistors V217 and V218 is adapted so as to compensate for the differences. This also applies to mains voltage fluctuations.

After rectifying and smoothing, the secondary voltages +5 V, +12 V, -12 V, +38 V, +180 V, -180 V, -1500 V and post acceleration voltage +8500 V are obtained. The voltage quintupler which supplies the +8500 V cannot be repaired and must be replaced when it breaks down.

T202 contains a separate secondary winding for the heater voltage for the C.R.T.

All supply voltages except the +8500 V and the -1500 V can be continuously short-circuited without damage to the components.

Resistor R207 limits the collector current when the output is short-circuited and the switching action is stopped, thereby holding the dissipated power in transistors V217 and V218 at a safe level. Thus, the power supply of the oscilloscope is fully protected against short-circuits. A short-circuit is indicated either by a squeeking noise coming from the power supply or by the pilot lamp B1, which indicates the ON state of the oscilloscope, failing to light up.

If supplied by an external d.c. voltage, the instrument is protected against overloads and wrong polarity by internal fuse F201 and diode V206.

2.10.3. Illumination circuit

The graticule of the C.R.T. can be illuminated by means of the bulbs E1. The intensity can be varied with the aid of ILLUM potentiometer R15 which controls the collector current (which is the current through the bulbs) of transistor V207. The illumination circuit is not short-circuit proof.

2.11. CALIBRATION UNIT

The calibrator circuit consists of transistors V1601 and V1603, which are configured as astable multivibrator such as used in the channel switch. Good shape of the wave-form is obtained by a constant current supplied by transistor V1602 which will flow in turns through the left hand or right hand transistor. The amplitude is 1,2 V or 6 div. in the 20 mV/div. attenuator positions. (The straight through position of the attenuator.) Potentiometer R1607 allows accurate adjustment of the amplitude of the calibrator output voltage. This square-wave output voltage is taken off from the collector of transistor V1603 and fed to socket X1. This is the front panel CAL terminal.

The calibrator output signal can be used for probe compensation and/or checking the vertical deflection accuracy.

2.12. BASIC ANALOG AND DIGITAL CIRCUITS

This section describes briefly the most important characteristics of the analog and digital circuits to be found in the instrument.

2.12.1. Basic analog circuits (see Fig. 2.9.)

– SERIES FEEDBACK AMPLIFIER

This is also called a Cherry configuration.

A voltage signal ΔU is applied to the input; the output produces a

$$\text{current signal } \Delta I = \frac{\Delta U}{R_E}$$

– SHUNT FEEDBACK AMPLIFIER

This is also called a Hooper configuration.

A current signal ΔI is applied to the input; the output produces a voltage signal $\Delta U = \Delta I \cdot R_F$

– SERIES FEEDBACK AMPLIFIER followed by a SHUNT FEEDBACK AMPLIFIER

This combination of the two previous configurations is called a Cherry-Hooper circuit.

In this two-stage amplifier, both the input and the output are voltage signals. The gain of this amplifier is:

$$\frac{\Delta U_{\text{OUT}}}{\Delta U_{\text{IN}}} = \frac{R_F}{R_E}$$

– EMITTER-FOLLOWER

The emitter-follower is used as an impedance converter.

The input impedance is HIGH and the output impedance is LOW. The stage has a voltage gain of x1, and the output voltage signal is identical to the input voltage.

–DARLINGTON PAIR

This circuit consists of two emitter-followers connected in cascade. As a result, the input impedance is very high and the output impedance low.

Again, this stage has a voltage gain of x1 and the output voltage signal is identical to the input voltage signal.

– COMMON BASE CIRCUIT

This type of circuit is frequently used between amplifier stages for d.c. voltage level adaption or for buffering. The input impedance is low and the output impedance is high.

It has a current gain of x1, the output current signal being identical to the input current signal.

– LONG-TAILED PAIR

In the diagram of Fig. 2.9, the long-tailed pair is formed by transistors V1 and V2. Transistor V3 functions as a constant-current source for V1 and V2.

The current drawn from V3 is divided between V1 and V2, the proportion depending on the base voltages applied (U1 and U2).

The division is as follows:

$$I_1 - I_2 = \frac{U_1}{R_{E1}} - \frac{U_2}{R_{E2}}$$

2.12.2. Basic digital circuits (see Fig. 2.10.)

The type of logic used is TTL and the supply voltage +5V.

The logic levels used are defined as follows:

- a high level (H) constitutes an input between 2 ... 5V and an output between 2.4 ... 5V.
- a low level (L) constitutes an input between 0 ... 0.8V and an output of between 0 ... 0.4V.

The following types of logic circuit elements are used in this instrument.

AND-gate: In this gate, the output is only H if all the inputs are H. Therefore, if one input is low, the state of the other inputs is irrelevant and the output is L.

NAND-gate: The output is only L if all the inputs are H. Therefore, if one input is L the state of the other inputs is irrelevant and the output is H.

OR-gate: The output is only L if all inputs are L. If one input is H, then the state of the other inputs is irrelevant and the output is H.

NOR-gate: The output is only H if all inputs are L. Therefore, if one input is H, the state of the other inputs is irrelevant and the output is L.

D-FLIP-FLOP: One integrated circuit incorporates two flip-flops. Each flip-flop has an output (pin 5 or 9) and an inverted output (pin 6 or 8). If the reset input R (pin 1 or 13) is made L it is activated and the flip-flop is forced to the reset state: output L and inverted output H. The set input S (pin 4 or 10) is active when L and forces the flip-flop to the set state: output H and inverted output L. If the set and reset inputs are both H, the condition of the clock input CL (pin 3 or 11) and the data input D (pin 2 or 12) are important. The logic level on the data input (L or H) is clocked into the flip-flop if the clock goes from L to H – now the output also becomes L or H.

JK FLIP-FLOP: One IC contains two flip-flops. Each flip-flop has an output (pin 5 or 9) and an inverted output (pin 6 or 7). If the reset input R (pin 15 or 14) is made L, it is activated and the flip-flop is forced to the reset condition: output L and inverted output H.

The set input S (pin 4 or 10) is active when L and forces the flip-flop to the set condition: output is H and inverted output is L.

If both the set and reset inputs are H, the condition of the clock input C (pin 1 or 13), the J-input (pin 3 or 11) and the K-input (pin 2 or 12) are important.

If the clock input goes from H to L, the following occurs:

- | | |
|---------------------|--|
| If J = L and K = L: | the output states remain unchanged. |
| If J = H and K = L: | the output becomes H and the inverting output L. |
| If J = L and K = H: | the output becomes L and the inverting output H. |
| If J = H and K = H: | the outputs switch to the opposite state. |

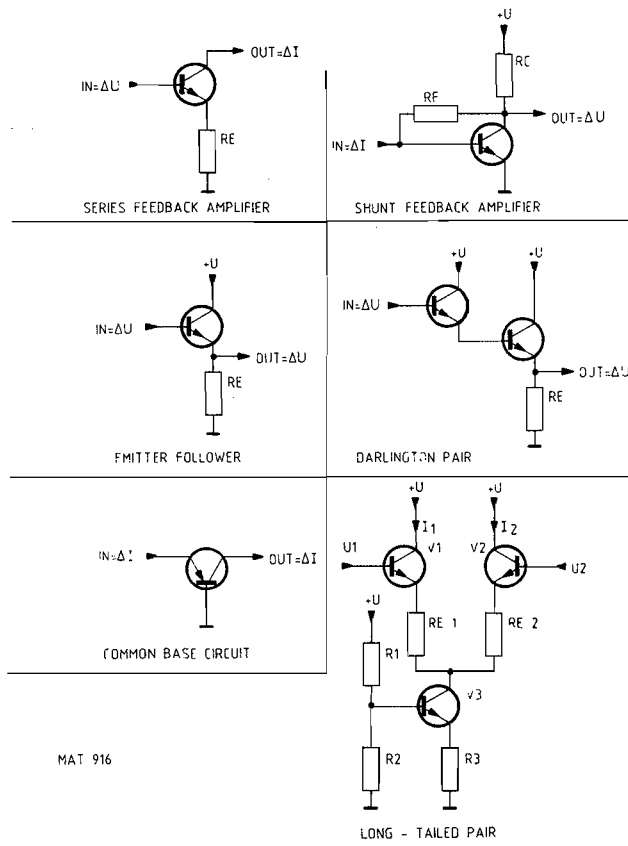

Fig. 2.9. Basic analog circuits

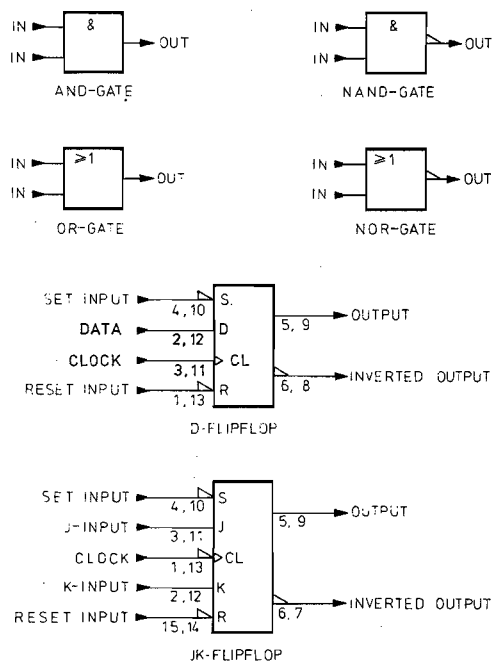

Fig. 2.10. Basic digital circuits

3. DISMANTLING THE INSTRUMENT

3.1. WARNING

The opening of covers or removal of part, except those to which access can be gained by hand, is likely to expose live parts, and also accessible terminals may be live.

The instrument shall be disconnected from all voltage sources before any adjustment, replacement or maintenance and repair during which the instrument will be opened.

If afterwards any adjustment, maintenance or repair of the opened instrument under voltage is inevitable, it shall be carried out only by a qualified person who is aware of the hazard involved.

Bear in mind that capacitors inside the instrument may still be charged even if the instrument has been separated from all voltage sources.

ATTENTION: This section provides the dismantling procedures required for the removal of components during repair operations. All circuit boards removed from the oscilloscope should be adequately protected against damage, and all normal precautions regarding the use of tools must be observed. During dismantling procedures, a careful note must be made of all disconnected leads that they may be reconnected to their correct terminals during assembly.

Damage may result if the instrument is switched on when a circuit board has been removed, or if a circuit board is removed within one minute after switching off the instrument.

3.2. REMOVING THE INSTRUMENT COVERS

The instrument is protected by three covers: a front panel protection cover, a wrap-around cover with carrying handle, and a rear panel.

To facilitate removal of the wrap-around cover and the rear panel, first ensure that the front cover is in position.

Then proceed as follows:

- Hinge the carrying handle clear of the front cover; to this end, push both pivot centre buttons (Fig. 3.1.)
- Stand the instrument on its protective front cover on a flat surface.
- Slacken the two coin-slot screws located on the rear panel.
- Lift the rear panel and unplug the connector on the power supply board.
- Lift off the wrap-around cover.
- For access to the front-panel, stand the instrument horizontally and snap off the front cover.

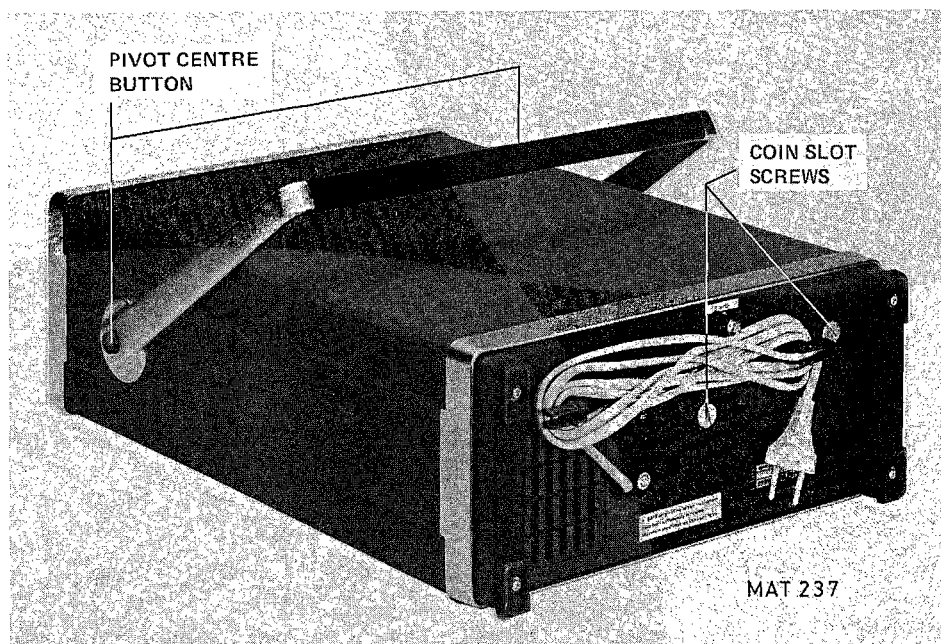

Fig. 3.1. Removing the instrument covers

3.3. REMOVING THE CARRYING HANDLE

- Prise off the centre knobs from each pivot, using a screwdriver (Fig. 3.2.) in one of the small slots at the sides of the knobs.
- Remove the cross-slotted screws that are now accessible.
- Bend both arms of the handle slightly outwards and take it off the cabinet.
- Grip and arms of the carrying handle must be ordered separately (see list of mechanical parts). A complete carrying handle can easily be constructed by pressing the arms into the grip.

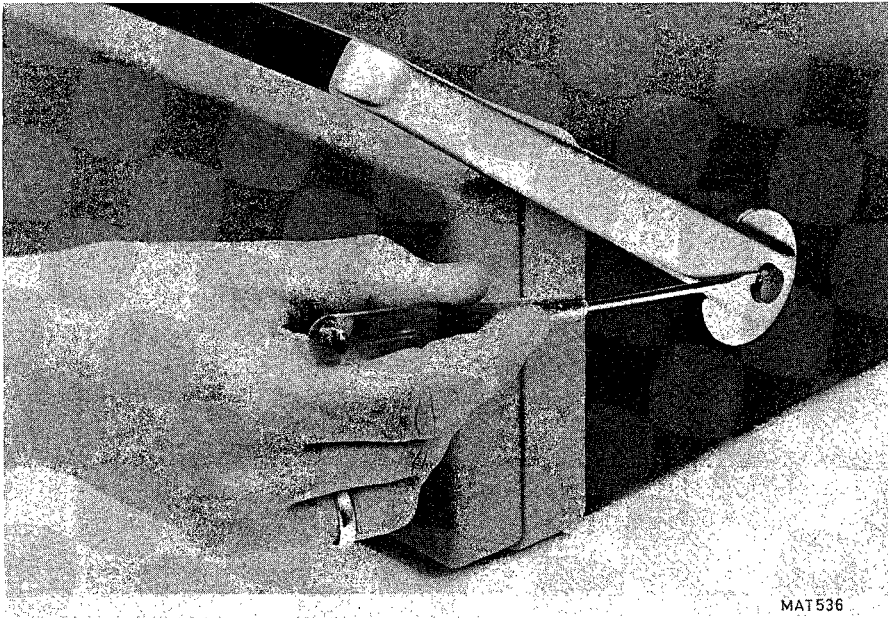

Fig. 3.2. Removing the carrying handle

3.4. ACCESS TO PARTS FOR CHECKING AND ADJUSTING PROCEDURE

All the adjustment elements can be reached after removing the instrument cover.

NOTE: For adjustment always use an insulated adjustment tool.

4. PERFORMANCE CHECK

4.1. GENERAL INFORMATION

WARNING: Before switching on, ensure that the oscilloscope has been installed in accordance with the instructions outlined in chapter 2 of the operating manual, Installation instructions.

This procedure is intended to be used for incoming inspection to determine the acceptability of newly purchased or recently recalibrated instruments.

It does not check every facet of the instrument's calibration; rather it is concerned primarily with those portions of the instrument which are essential to measurement accuracy and correct operation. Removing the instrument covers is not necessary to perform this procedure. All checks are made from the front panel.

If this test is started a few minutes after switching on, bear in mind that test steps may be out of specification, due to insufficient warming-up time. To avoid this situation, allow the specified warming-up time.

The performance checks are made with a stable, well-focused, low-intensity display. Unless otherwise noted, adjust the intensity and trigger-level controls as needed.

Note 1: At the start of every check, the controls always occupy the preliminary settings; unless otherwise stated.

Note 2: The input voltage has to be supplied to the A-input; unless otherwise stated.

Note 3: Set the TIME/DIV switches to a suitable position; unless otherwise stated.

4.2. PRELIMINARY SETTINGS OF THE CONTROLS

- Start this check procedure with **NO** input signals connected, **ALL** pushbuttons released and **ALL** switches in the CAL position.
- Depress the controls as indicated in figure 4.1.

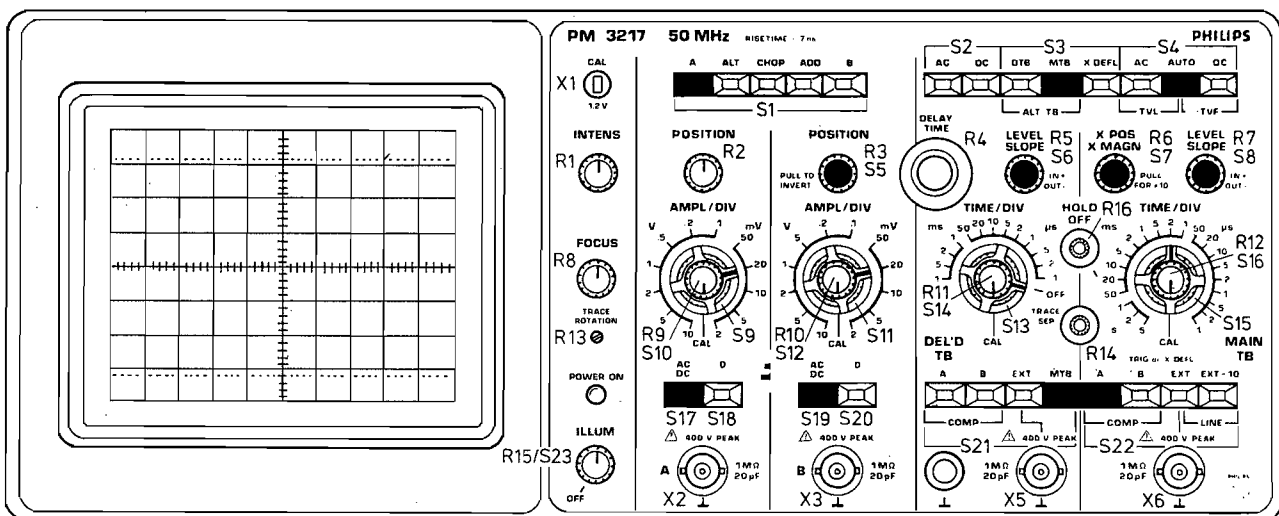

MAT 1052

Fig. 4.1. Preliminary settings of the controls

4.3. RECOMMENDED TEST EQUIPMENT

Type instrument	Required specification	Example of recommended instrument
Function generator	Freq.: 1 mHz ... 10 MHz Sine-wave/Square-wave Ampl.: 0 ... 40 Vp-p DC offset 0 ... ± 10 V Rise-time < 30 ns Duty cycle 50 %	Philips PM 5167
Constant amplitude sine-wave generator	Freq.: 100 kHz ... 60 MHz Constant ampl. of 120 mVp-p and 3 Vp-p	Tektronix SG 503
Square-wave calibration generator	Freq.: 10 Hz ... 1 MHz Ampl.: 50 mV ... 60 V Rise-time < 1 ns Duty cycle 50 %	Tektronix PG 506
Time-marker generator	Repetition rate: 0,5 s ... 0,05 μ s	Tektronix TG 501
Variable mains transformer	Well-insulated output voltage 90 ... 264 Vac	Philips ord. number 2422 529 00005
DC power supply	Adjustable output: 20 ... 28 V Current: 1,5 A	Philips PE 1540
Moving-iron meter		
Dummy probe 2 : 1	1 M Ω \pm 0,1% // 25pF	
Cables, T-piece, terminations for the generators	General Radio types for fast rise-time square-wave and freq. sine-wave. BNC-typer for other applications	





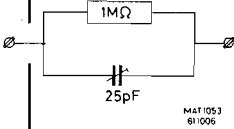



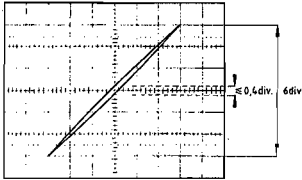

4.4. CHECKING PROCEDURE

STEP	OBJECTIVE	INPUT VOLTAGE	SETTINGS	REQUIREMENTS	MEASURING RESULTS																								
4.4.1.	POWER ON																												
4.4.1.a.	Start POWER ON a.c.		Set POWER ON switch S23 to ON	<ul style="list-style-type: none"> Starts at selected mains voltage $\pm 10\%$ and mains frequency 50-400Hz $\pm 10\%$ Pilot lamp POWER ON lights up 30W from a.c. 																									
4.4.1.b.	Power consumption																												
4.4.1.2.a.	Start POWER ON battery		Set POWER ON switch S23 to ON	<ul style="list-style-type: none"> Starts at battery supply voltages between 22V and 27V Pilot lamp POWER ON lights up 1,1A approx. 																									
4.4.1.2.b.	Current rating																												
4.4.2.	CRT SECTION																												
4.4.2.1.	Intens		INTENS potentiometer R1	Normal intens adjusting																									
4.4.2.2.	Focus		FOCUS potentiometer R8	Trace sharpness adjusting																									
4.4.2.3.	Trace rotation		Screwdriver adjustment TRACE ROT R13	Trace must be in parallel with horizontal graticule lines; if necessary, readjust potentiometer TRACE ROT R13																									
4.4.3.	VERTICAL AXIS																												
4.4.3.1.	Display modes	Sine wave signal 60mVp-p, 2kHz to A and B input	<ul style="list-style-type: none"> AMPL/DIV to 20mV/div Depress A of S1 Depress CHOP of S1 Depress ALT of S1 Depress ADD of S1 Depress B of S1 	<ul style="list-style-type: none"> Signal of 3 div. is visible on the screen Traces of ch. A and ch. B are visible on the screen. Traces of ch. A and ch. B are visible on the screen. Signal of 6 div. is visible on the screen Signal of 3 div. is visible on the screen 																									
4.4.3.2.	Polarity inversion ch.B.	as 4.4.3.1.	Pull the PULL TO INVERT switch S5	Display is inverted																									
4.4.3.3.	Input coupling	Sine-wave signal, 2kHz + DC offset to A (B) input	<ul style="list-style-type: none"> Depress 0 of S18 (S20) Release 0 of S18 (S20) Release S17 (S19) to DC 	<ul style="list-style-type: none"> Set the trace in the centre of the screen Signal is visible on the screen, centre of the sine-wave is on the vertical centre of the screen Signal is visible on the screen, centre of the sine-wave is on DC-offset level 																									
4.4.3.4.	Vertical deflection coefficients	Square wave signal, 2kHz to A (B) input	AMPL/DIV switch position of S9 (S11)																										
		<table border="0"> <tr> <td>Ampl: 12mVp-p</td> <td>2mV</td> </tr> <tr> <td>30mVp-p</td> <td>5mV</td> </tr> <tr> <td>60mVp-p</td> <td>10mV</td> </tr> <tr> <td>120mVp-p</td> <td>20mV</td> </tr> <tr> <td>300mVp-p</td> <td>50mV</td> </tr> <tr> <td>600mVp-p</td> <td>0,1V</td> </tr> <tr> <td>1,2Vp-p</td> <td>0,2V</td> </tr> <tr> <td>3 Vp-p</td> <td>0,5V</td> </tr> <tr> <td>6 Vp-p</td> <td>1 V</td> </tr> <tr> <td>12 Vp-p</td> <td>2 V</td> </tr> <tr> <td>30 Vp-p</td> <td>5 V</td> </tr> <tr> <td>30 Vp-p</td> <td>10 V</td> </tr> </table>	Ampl: 12mVp-p	2mV	30mVp-p	5mV	60mVp-p	10mV	120mVp-p	20mV	300mVp-p	50mV	600mVp-p	0,1V	1,2Vp-p	0,2V	3 Vp-p	0,5V	6 Vp-p	1 V	12 Vp-p	2 V	30 Vp-p	5 V	30 Vp-p	10 V		<ul style="list-style-type: none"> Trace height 6 div. $\pm 3\%$ ($\pm 0,9$ subdiv.) Trace height 6 div. $\pm 3\%$ ($\pm 0,9$ subdiv.) Trace height 6 div. $\pm 3\%$ ($\pm 0,9$ subdiv.) Trace height 6 div. $\pm 3\%$ ($\pm 0,9$ subdiv.) Trace height 6 div. $\pm 3\%$ ($\pm 0,9$ subdiv.) Trace height 6 div. $\pm 3\%$ ($\pm 0,9$ subdiv.) Trace height 6 div. $\pm 3\%$ ($\pm 0,9$ subdiv.) Trace height 6 div. $\pm 3\%$ ($\pm 0,9$ subdiv.) Trace height 6 div. $\pm 3\%$ ($\pm 0,9$ subdiv.) Trace height 6 div. $\pm 3\%$ ($\pm 0,9$ subdiv.) Trace height 3 div. $\pm 3\%$ ($\pm 0,45$ subdiv.) 	
Ampl: 12mVp-p	2mV																												
30mVp-p	5mV																												
60mVp-p	10mV																												
120mVp-p	20mV																												
300mVp-p	50mV																												
600mVp-p	0,1V																												
1,2Vp-p	0,2V																												
3 Vp-p	0,5V																												
6 Vp-p	1 V																												
12 Vp-p	2 V																												
30 Vp-p	5 V																												
30 Vp-p	10 V																												
4.4.3.5.	Continuous control	Square wave signal 120mVp-p, 2kHz to A.(B) input	<ul style="list-style-type: none"> AMPL/DIV switch position of S9 (S11) to 20mV/div. Continuous control R9 (R10) 	Continue range 1 : $\geq 2,5$ ($\leq 2,4$ div.)																									

STEP	OBJECTIVE	INPUT VOLTAGE	SETTINGS	REQUIREMENTS	MEASURING RESULTS
4.4.3.6.	Vertical deflection via dummy 	Square wave signal, 2kHz to A (B) input via dummy AMPL: 24mVp-p 60mVp-p 120mVp-p 240mVp-p 600mVp-p 1,2Vp-p 2,4Vp-p 6 Vp-p 12 Vp-p 24 Vp-p 30 Vp-p 40 Vp-p	AMPL/DIV switch position of S9 (S11) 2mV 5mV 10mV 20mV 50mV 0,1V 0,2V 0,5V 1 V 2 V 5 V 10 V	Trace height 6 div. ± 3% (± 0,9 subdiv.) Trace height 6 div. ± 3% (± 0,9 subdiv.) Trace height 6 div. ± 3% (± 0,9 subdiv.) Trace height 6 div. ± 3% (± 0,9 subdiv.) Trace height 6 div. ± 3% (± 0,9 subdiv.) Trace height 6 div. ± 3% (± 0,9 subdiv.) Trace height 6 div. ± 3% (± 0,9 subdiv.) Trace height 6 div. ± 3% (± 0,9 subdiv.) Trace height 6 div. ± 3% (± 0,9 subdiv.) Trace height 6 div. ± 3% (± 0,9 subdiv.) Trace height 6 div. ± 3% (± 0,9 subdiv.) Trace height 3 div. ± 3% (± 0,45 subdiv.) Trace height 2 div. ± 3% (± 0,3 subdiv.)	
4.4.3.7.	Common mode rejection	Sine-wave signal 480mV, 1MHz to A and B input	– AMPL/DIV switches to 20mV – Pull the PULL TO INVERT switch S5 – Depress ADD of S1	Rejection > 100 (signal < 0,25 div.)	
4.4.3.8.	Dynamic range	Sine-wave signal 2,4V, 10MHz to A (B) input	– AMPL/DIV to 0,1V – Position control R2 (R3)	24 div. trace height distortion free visible on the screen	
4.4.3.9.	Vertical positioning	Sine-wave signal 2,4V 10kHz to A (B) input	as 4.4.3.8.	Top of sine-wave signal visible on the screen in both extreme positions of the POSITION CONTROL	
4.4.3.10.	Trace jump a. attenuator b. 20mV → 10mV c. normal/invert		– Depress 0 of S18 (S20) – Set trace in centre of the screen – All positions of AMPL/DIV S9 (S11) except b. – AMPL/DIV switch S9 (S11) between 20mV → 10mV – Pull and push switch S5	Trace jump ≤ 0,1 div. Trace jump ≤ 1 div. Trace jump ≤ 1 div.	
4.4.3.11.	Square wave response	Square wave signal 120mVp-p, 1MHz risetime ≤ 1nsec.	– AMPL/DIV switch S9 (S11) to 20mV	Trace height 6 div. Pulse aberrations ≤ 3% (≤ 5% p-p) Risettime ≤ 7nsec.	
4.4.3.12.	Visible signal delay	as 4.4.3.11.	– AMPL/DIV to 20mV – PULL X MAGN S7 – MTB TIME/DIV to 0,1μs	Leading edge visible on the screen	
4.4.3.13.	Bandwith	Sine-wave signal to A (B) input 1MHz 1MHz - 50MHz		Adjust the sine-wave amplitude for a trace height of 6 div. Trace height ≥ 4,2 div.	
4.4.4.	HORIZONTAL AXIS				
4.4.4.1.	Display modes	Sine-wave signal 120mVp-p, 2kHz	– AMPL/DIV to 50mV – MTB TIME/DIV to 0,2ms – Depress MTB of S3 – DTB TIME/DIV to 50μs – Depress DTB of S3 – Depress DTB and MTB of S3 (=ALT TB) – Depress X DEFL of S3	Sine-wave signal 2,4 div. high (MTB trace) Intensified part DTB is visible on the screen. DTB trace visible on the screen. MTB trace with intensified part and DTB trace visible on the screen Horizontal deflection is determined by the input signal A (2,4 div.)	
4.4.4.2.	Trace separation		– MTB TIME/DIV to 0,2ms – DTB TIME/DIV to 50μs – Depress MTB and DTB (=ALT TB) of S3 – Trace SEP control R12 – Trace SEP control R12	Both time-base lines cover each other (e.g. one line) MTB trace (with intensified part) 2 div. upwards and DTB trace 2 div. downwards.	
4.4.4.3.	X positioning range		X POS control R6 X POS control R6	Starting point of trace to horizontal centre of the screen End of trace to horizontal centre of the screen	

STEP	OBJECTIVE	INPUT VOLTAGE	SETTINGS	REQUIREMENTS	MEASURING RESULTS
4.4.5.	MAIN TIME-BASE				
4.4.5.1.	Time coefficients	Marker pulse signal to A input Repetition time: 0,1 μsec 0,2 μsec 0,5 μsec 1 μsec 2 μsec 5 μsec 10 μsec 20 μsec 50 μsec 0,1 msec 0,2 msec 0,5 msec 1 msec 2 msec 5 msec 10 msec 20 msec 50 msec 0,1 sec 0,2 sec 0,5 sec	– Depress MTB of S3 – MTB TIME/DIV switch positions: 0,1 μs 0,2 μs 0,5 μs 1 μs 2 μs 5 μs 10 μs 20 μs 50 μs 0,1 ms 0,2 ms 0,5 ms 1 ms 2 ms 5 ms 10 ms 20 ms 50 ms 0,1 s 0,5 s 0,5 s	Coefficient error ≤ 3% (c.i. 0,3 div. over 10 div. screenwidth)	
4.4.5.2.	X Magnifier	Marker pulse to A input, repetition time 0,1 msec	– MTB TIME/DIV switch to 1 msec – PULL X MAGN S7	Coefficient error ≤ 5% (c.i. 0,5 div. over 10 div. screenwidth)	
4.4.5.3.	Continuous control	as 4.4.5.2.	– MTB TIME/DIV switch to 10 μsec – Continuous control R12	Continuous range 1 : ≥ 2,5	
4.4.6.	DELAYED TIME-BASE				
4.4.6.1.	Time coefficients	Marker pulse signal to A input repetition time 0,1 μsec 0,2 μsec 0,5 μsec 1 μsec 2 μsec 5 μsec 10 μsec 20 μsec 50 μsec 0,1 msec 0,2 msec 0,5 msec 1 msec	Depress DTB of S3 MTB TIME/ DIV S15 DTB TIME DIV S13 0,2 μs 0,1 μs 0,5 μs 0,2 μs 1 μs 0,5 μs 2 μs 1 μs 5 μs 2 μs 10 μs 5 μs 20 μs 10 μs 50 μs 20 μs 0,1 ms 50 μs 0,2 ms 0,1 ms 0,5 ms 0,2 ms 1 ms 0,5 ms 2 ms 1 ms	Coefficient error ≤ 3% (c.i. 0,3 div. over 10 div. screenwidth)	
4.4.6.2.	X Magnifier	Marker pulse to A input, repetition time 10 μsec	– MTB TIME/DIV to 0,2ms – DTB TIME/DIV to 0,1ms – PULL X MAGN S7	Coefficient error ≤ 3% (c.i. 0,3 div. over 10 div. screenwidth)	
4.4.6.3.	Continuous control	as 4.4.6.2.	– MTB TIME/DIV to 2 μs – DTB TIME/DIV to 1 μs – Continuous control R11	Continuous range 1 : ≥ 2,5	
4.4.6.4.	Delay time	as 4.4.6.2.	– MTB TIME/DIV to 1ms – DTB TIME/DIV to 10 μs – DELAY TIME control R4 to 0,00 – Set start MTB-trace on first vertical graticule line – DELAY TIME control R4 to 10,00	Intensified part (DTB) starts at the same point as the MTB trace Intensified part (DTB) starts at the last vertical graticule line (incremental delay time error ± 0,5%)	

STEP	OBJECTIVE	INPUT VOLTAGE	SETTINGS	REQUIREMENTS	MEASURING RESULTS
4.4.7.	XY-DEFLECTION				
4.4.7.1.	Mode A (B)	Sine-wave signal 120mVp-p, 2kHz to A (B) input	Depress A (B) of S1 Depress A (B) of S22 Depress X DEFL of S3 AMPL/DIV to 20mV	A line is visible with an angle of 45° with respect to the horizontal graticule line; trace height and trace width 6 div. $\pm 10\%$ (c.i. $\pm 0,6$ div.)	
4.4.7.2.	Mode EXT	Sine-wave signal 1,6Vp-p, 2kHz to EXT input X6	Depress EXT of S22 Depress X DEFL of S3	Trace width 8 div. $\pm 10\%$	
4.4.7.3.	Mode EXT $\div 10$	Sine-wave signal 16Vp-p, 2kHz to EXT input X6	Depress EXT $\div 10$ of S22 Depress X DEFL of S3	Trace width 8 div. $\pm 10\%$	
4.4.7.4.	Mode LINE		Depress LINE of S22 Depress X DEFL of S3	Trace width 8 div. $\pm 10\%$	
4.4.7.5.	Bandwidth	Sine-wave signal, 2kHz to EXT input X6 1MHz 1MHz 1MHz	Depress EXT of S22 Depress X DEFL of S3 Depress DC of S4 Depress AC of S4	Adjust the input voltage for a trace width of 8 div. Trace width $\geq 5,6$ div. Trace width $\geq 5,6$ div. Trace width $\geq 5,6$ div.	
4.4.7.6.	Dynamic range	Sine-wave signal, 100kHz to A input	– Depress X DEFL of S3 – Depress B of S1 – AMPL/DIV to 0,2V – AMPL/DIV to 50mV	Adjust the input voltage for a horizontal deflection of 6 div. Horizontal deflection 24 div.	
4.4.7.7.	Phase shift between X and Y ampl.	Sine-wave signal to 2kHz A-input 100kHz	– Depress X DEFL of S3 – AMPL/DIV to 20mV	Adjust the input voltage for a horizontal deflection of 6 div. Phase shift $\leq 3^\circ$ (c.i. $\leq 0,4$ div.)	
					
4.4.8.	MTB TRIGGERING				
4.4.8.1.	Trigger source A and B	Sine-wave signal, 10kHz to A input and square wave signal, 2kHz to B input	– Depress ALT of S1 – Depress MTB of S3 – Adjust the input signals for a trace height of 6 div. approx. – Depress B of S22 – Depress COMP of S22	Well triggered display of channel A Well triggered display of channel B Well triggered display of channel A and channel B	
4.4.8.2.	Trigger source EXT	Sine-wave signal, 240mV, 2kHz to A input and EXT input X6	Depress EXT of S22	Well triggered display	
4.4.8.3.	Trigger source LINE	Sine-wave signal, related to mains frequency to A input	Depress LINE of S22	Well triggered display	
4.4.8.4.	Slope	Sine-wave signal, 120mV, 2kHz to A input	– Push SLOPE S8 – Pull SLOPE S8	Signal triggers on positive going edge Signal triggers on negative going edge	
4.4.8.5.	Sensitivity INT	Sine-wave signal to A input frequency: 1Hz 5Hz 20Hz 5MHz 50MHz	Depress DC of S4 Depress AC of S5 Depress AUTO of S4	Signal triggers at 0,5 div. Signal triggers at 0,5 div. Signal triggers at 0,5 div. Signal triggers at 0,5 div. Signal triggers at 1 div.	
4.4.8.6.	Sensitivity EXT	Sine-wave signal to A input and EXT input X6 frequency: 5MHz 50MHz 5MHz 50MHz	Depress EXT of S22 Depress EXT $\div 10$ of S22	Signal triggers at 0,15Vp-p Signal triggers at 0,2Vp-p Signal triggers at 1,5Vp-p Signal triggers at 2Vp-p	

STEP	OBJECTIVE	INPUT VOLTAGE	SETTINGS	REQUIREMENTS	MEASURING RESULTS
4.4.8.7.	LEVEL range	Sine-wave signal 60mVp-p, 2kHz to A input	LEVEL control R7 	Trace is triggered in the most extreme positions of the LEVEL control	
			Depress DC of S4 LEVEL control R7 	Trace is not triggered in the most extreme positions of the LEVEL control	
			AMPL/DIV to 10mV LEVEL control R7 	Trace is triggered in the most extreme positions of the LEVEL control (range ≥ 4 div.)	
		Sine-wave signal 1Vp-p, 2kHz to A input and EXT input X6	Depress EXT of S22 LEVEL control R7 	Trace is triggered in the most extreme positions of the LEVEL control (range $\geq 0,8V$)	
4.4.8.8.	EXT trigger input impedance	Sine-wave signal 1Vp-p, 2kHz to A input and to EXT input via dummy	Depress EXT of S22 LEVEL control R7 	Trace is not triggered in the most extreme positions of the LEVEL control	
		Sine-wave signal 2Vp-p, 2kHz to A input and to EXT input via dummy	LEVEL control R7 	Trace is triggered in the most extreme positions of the LEVEL control	
4.4.9.	DTB TRIGGERING				
4.4.9.1.	Trigger source	Sine-wave signal, 10kHz to A input and square wave signal, 2kHz to B input	– Depress ALT of S1 – Depress DTB of S3 – Depress COMP of S22 – Adjust the input voltages for a trace height of 6 div. approx. – Depress A of S21 – Depress B of S21 – Depress COMP of S21	Well triggered display of channel A and channel B Well triggered display of channel A Well triggered display of channel B Well triggered display of channel A and channel B Well triggered display	
		Sine-wave signal, 240mV, 2kHz to A input and EXT input X5	– Depress EXT of S21		
4.4.9.2.	SLOPE	Sine-wave signal, 120mV, 2kHz to A input	– Depress DC of S2 – Depress DTB of S3 – MTB TIME/DIV to 0,5ms – DTB TIME/DIV to 0,2ms – Depress A of S21 – Pull SLOPE S6	Signal triggers on positive going edge Signal triggers on negative going edge	
4.4.9.3.	Sensitivity INT	Sine-wave signal to A input frequency: 1 Hz 5 Hz 5MHz 50MHz	– Depress DC of S2 – Depress DTB of S3 – Depress A of S21 – Depress AC of S2	Signal triggers at 0,5 div. Signal triggers at 0,5 div. Signal triggers at 0,5 div. Signal triggers at 2 div.	
4.4.9.4.	Sensitivity EXT	Sine-wave signal to A input and EXT input X5 frequency: 5MHz 50MHz	– Depress DC of S2 – Depress DTB of S3 – Depress EXT of S21	Signal triggers at 0,15Vp-p Signal triggers at 0,4Vp-p	
4.4.9.5.	LEVEL range	Sine-wave signal 60mVp-p, 2kHz to A input	– Depress DC of S2 – Depress DTB of S3 – MTB TIME/DIV to 0,5ms – DTB TIME/DIV to 0,2ms – Depress A of S21 – LEVEL control R5 	Trace is not triggered in the most extreme positions of the LEVEL control	
			– AMPL/DIV to 5mV – LEVEL control R5 	Trace is triggered in the most extreme positions of the LEVEL control (range ≥ 8 div.)	
		Sine-wave signal 2Vp-p, 2kHz to A input and EXT input X5	– AMPL/DIV to 1V – Depress EXT of S21 – LEVEL control R5 	Trace is triggered in the most extreme positions of the LEVEL control (range $\geq 1,6V$)	
4.4.9.6.	EXT trigger input impedance	Sine-wave signal 2Vp-p, 2kHz to A input and to EXT input X5 via dummy	– Depress DC of S2 – Depress DTB of S3 – Depress EXT of S21 – LEVEL control R5 	Trace is not triggered in the most extreme positions of the LEVEL control	
		Sine-wave signal 1,5Vp-p, 2kHz to A input and to EXT input X5 via dummy	– LEVEL control R5 	Trace is triggered in the most extreme positions of the LEVEL control	
4.4.10	CALIBRATION			Calibration voltage is 1,2Vp-p Calibration frequency is ≈ 2 kHz square wave	
4.4.11.	Z-MODULATION (additional)	TTL compatible signal to Z-MOD input at the rear side		Logic "1" is normal intensity Logic "0" is blanked	

5. CHECKING AND ADJUSTING

WARNING: The opening of covers or removal of parts, except those to which access can be gained by hand, is likely to expose live parts, and also accessible terminals may be live. The instrument shall be disconnected from all voltage sources before any adjustment, replacement or maintenance and repair during which the instrument will be opened. If afterwards any adjustment, maintenance or repair of the opened instrument under voltage is inevitable, it shall be carried out only by a qualified person who is aware of the hazard involved. Bear in mind that capacitors inside the instrument may still be charged even if the instrument has been separated from all voltage sources.

5.1. GENERAL INFORMATION

The following information provides the complete checking and adjusting procedure for the oscilloscope. As various control functions are interdependent, a certain order of adjustment is often necessary.

The procedure is, therefore, presented in a sequence which is best suited to this order, cross-reference being made to any circuit which may affect a particular adjustment.

Before any check or adjustment, the instrument must attain its normal operating temperature.

- Where possible, instrument performance is checked before an adjustment is made.
- Warming-up time under average conditions is 30 minutes.
- All limits and tolerances given in this section are calibration guides and should not be interpreted as instrument specifications unless they are also published in chapter 1.2. characteristics.
- Tolerances given are for the instrument under test and do not include test equipment error.
- The most accurate display adjustments are made with a stable, well-focused, low-intensity display. Unless otherwise noted, adjust the Intensity, Focus and Trigger Level controls as needed.
- Unless otherwise noted the controls occupy the same position as in the previous check.

5.2. RECOMMENDED TEST EQUIPMENT

As indicated in chapter 4.3.

Additional equipment for the checking and adjusting procedure:

Digital multimeter e.g. PM 2522 (A).

Trimming tool set e.g. Philips 800 NTX.

5.3. PRELIMINARY SETTINGS OF THE CONTROLS

As indicated in chapter 4.2.

5.4. SURVEY OF ADJUSTING ELEMENTS AND AUXILIARY EQUIPMENT

ADJUSTMENT	ADJUSTING ELEMENT	ADJUSTING RESULT	RECOMMENDED INSTRUMENT AND INPUT SIGNALS	CHAPTER	FIGURES
Power supply Supply voltage adjustment	R204	+ 12V, + or - 0,25V	Digital multimeter	5.5.1.	5.3.
Cathode-ray tube circuit					
Intensity	R1537	Spot just not visible	—	5.5.2.	5.1.
Intens ratio	R1507	MTB trace just visible	—	5.5.2.	5.1
Trace rotation	R13	Trace runs exactly in parallel with horizontal graticule lines.	—	5.5.2.	—
Focus and astigmatism	R1543	Sharp and well-defined trace.	Function generator, sine-wave signal 10kHz.	5.5.2.	5.3.
Geometrie	R1549	Displayed vertical lines as straight as possible and signal must fall in area.	Function generator, sine-wave signal 10kHz.	5.5.2.	5.3.
Y-Amplifier balance.					
DC balance	R504 (R604)	Minimum jump when switching 10mV - 20mV	—	5.5.3.	5.1.
Gain balance	R514 (R614)	Minimum jump when rotating AMP/L/DIV control	—	5.5.3.	5.1.
Normal/invert balance ch.B	R647	Minimum jump when switching normal-invert.	—	5.5.3.	5.1.
Shift balance	R547 (R674)	Sine-wave displayed distortion free.	Function generator, sine-wave signal 10kHz.	5.5.3.	5.1.
Trigger balances					
A-balance	R456 (R351)	Starting point DTB and MTB is the same	Function generator, sine-wave signal 2kHz.	5.5.4.	5.2.
B-balance	R458 (R356)	Starting point DTB and MTB is the same	Function generator, sine-wave signal 2kHz.	5.5.4.	5.2.
COMP-balance	R453 (R353)	Starting point DTB and MTB is the same	Function generator, sine-wave signal 2kHz.	5.5.4.	5.2.
Time-base generators.					
MTB time coefficients	R1417	Centre 8 cycles occupy 8 divisions.	Time marker generator, time marker pulse 1 μ sec.	5.5.5.	5.1.
	R1419	Centre 8 cycles occupy 8 divisions.	Time marker generator, time marker pulse 0,1 μ sec.	5.5.5.	5.1.
	R1216	Centre 8 cycles occupy 8 divisions	Time marker generator, time marker pulse 1msec.	5.5.5.	5.1.
	R1409	Beginning of the time-base as linear as possible.	Time marker generator, time marker pulse 10nsec.	5.5.5.	5.1.

DTB time coefficients	R1336	Centre 8 cycles occupy 8 divisions	Time marker generator, time marker pulse 1 μ sec.	5.5.5.	5.1.
	R1344	Centre 8 cycles occupy 8 divisions	Time marker generator, time marker pulse 0,1msec.	5.5.5.	5.1.
Delay time multiplier	R1319	DTB spot on the second time marker pulse	Time marker generator, time marker pulse 1 μ sec.	5.5.5.	5.1.
	R1318	DTB spot on the tenth time marker pulse	Time marker generator, time marker pulse 1 μ sec.	5.5.5.	5.1.
Trace separation	R1420	Difference between MTB and DTB trace at least 3div.	—	5.5.5.	5.1.
Vertical channels					
Gain sensitivity x1	R848 (R543)	Signal occupies 6 divisions.	Function generator, square-wave signal 2kHz.	5.5.6.	5.1.
Gain sensitivity x10	R621 (R521)	Signal occupies 6 divisions.	Function generator, square-wave signal 2kHz.	5.5.6.	5.1.
Square-wave resp. attenuators	C407 (C307) C413 (C313) C414 (C314) C416 + C418 (C316 + C318) C417 + C419 (C317 + C319)	Optimal square-wave response pulse top errors + or - 0,5 subdiv. trace height 6div. + or - 0,5 subdiv. AMPL/DIV 20mV AMPL/DIV 50mV AMPL/DIV 0,1 V AMPL/DIV 0,2 V AMPL/DIV 2 V	Square-wave calibration generator, frequency 10kHz and risetime \leq 100nsec.	5.5.6.	5.2.
Square-wave response final amplifier	R813 R812 R814 C809 C811 R817 C809 C811 L801 L802 C602 (C502) C508	Optimal square-wave response pulse top errors + or - 0,5 subdiv. and risetime \leq 7nsec. freq. 10 Hz 100kHz 100kHz-1MHz 100kHz-1MHz 100kHz-1MHz 1MHz 1MHz 1MHz 1MHz 1MHz 1MHz	Square-wave calibration generator frequency 10kHz - 1MHz and risetime \leq 3nsec.	5.5.6.	5.1.
Cross talk	R812 + R813	Minimum cross talk	Square-wave calibration generator, frequency 10kHz, risetime \leq 3nsec.	5.5.6.	5.1.
Triggering					
Trigger sensitivity	R1016-R1107	MTB - DTB trace is triggered	Function generator, square wave signal 2kHz.	5.5.7.	5.1.
Calibration					
Calibration voltage	R1607	Square-wave voltage 1,2Vp-p \pm 0,7%	—	5.5.9.	5.1.

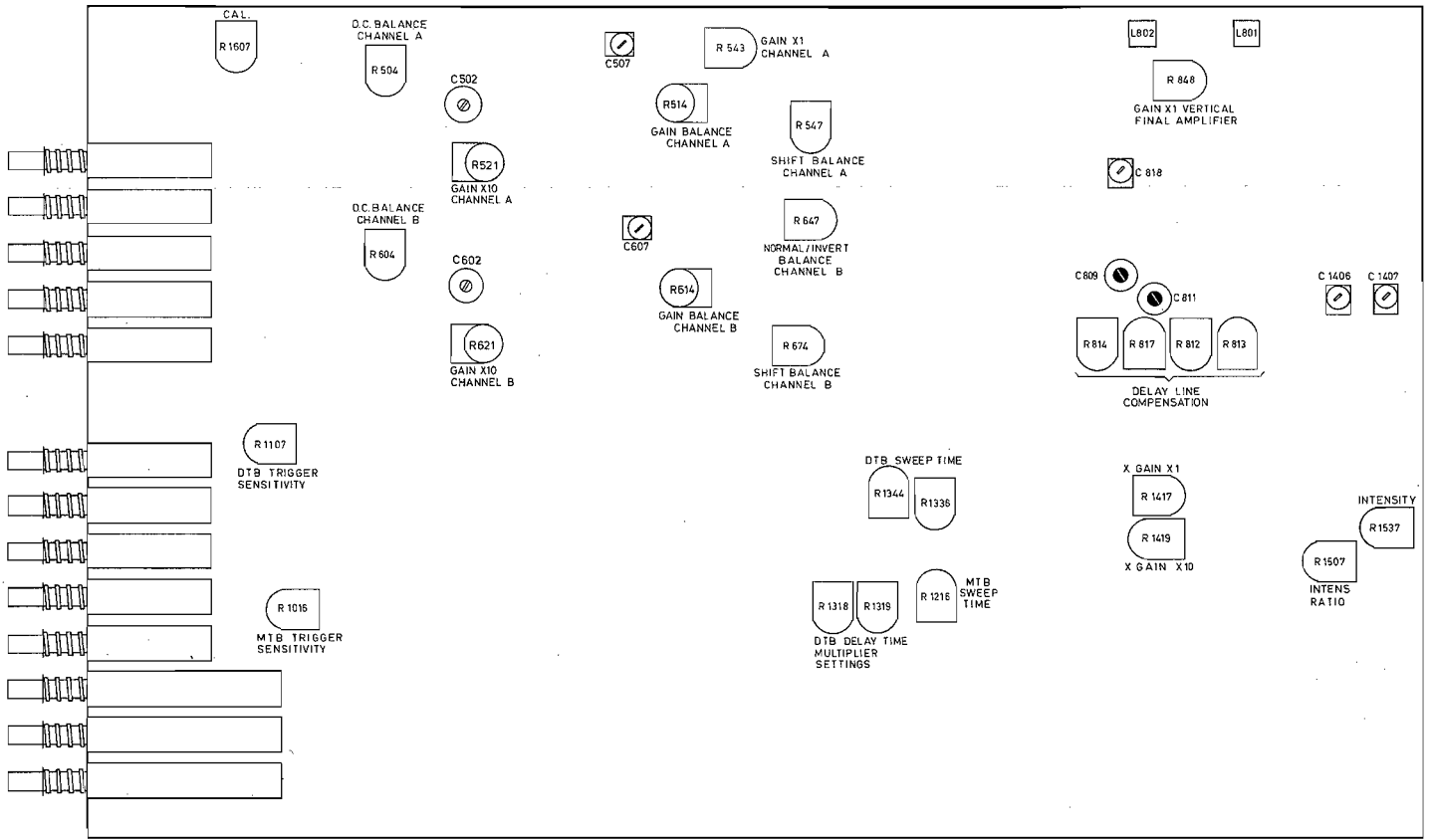

Fig. 5.1.

MAT1064
81027

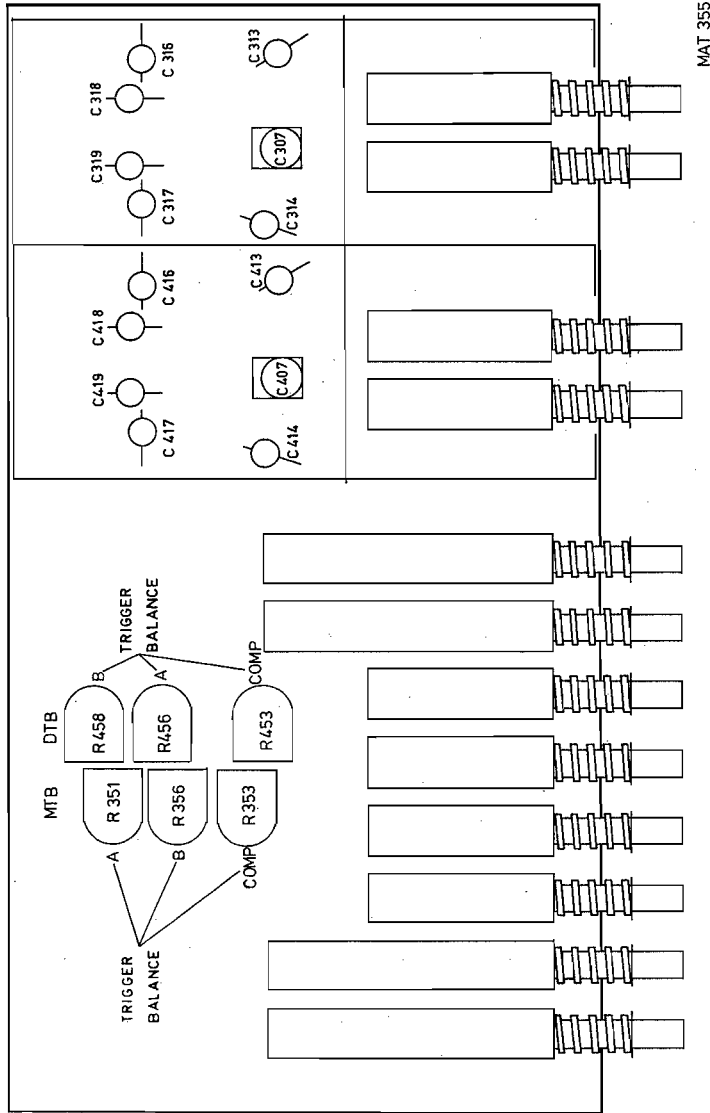

Fig. 5.2.

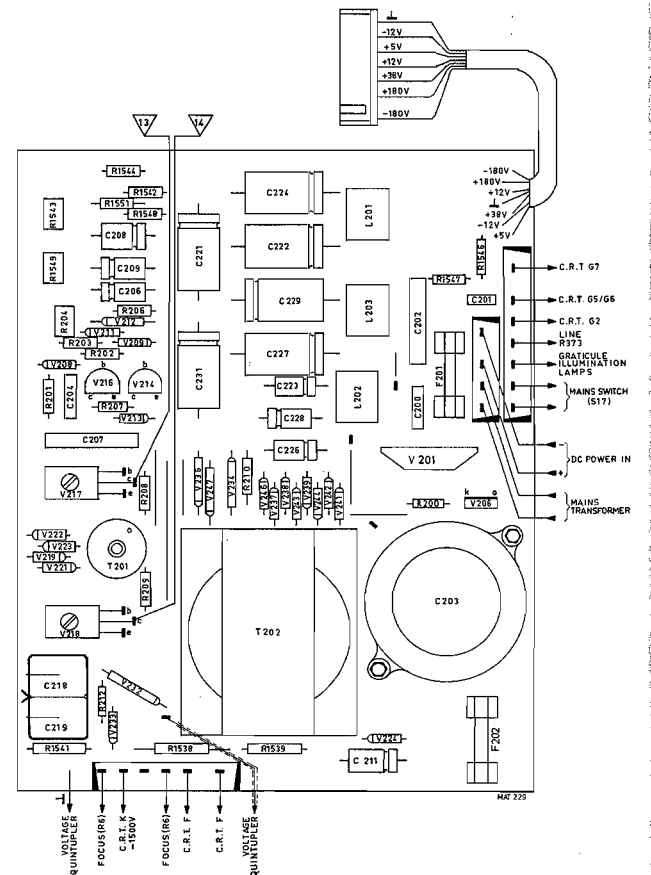

Fig. 5.3.

MR 228

5.5. CHECKING AND ADJUSTING PROCEDURE

The adjusting elements are indicated in Fig. 5.1., 5.2. and 5.3.

5.5.1. Power supply

Mains current

- Check that the mains voltage adapter has been set to the local mains voltage and connect the instrument to such a voltage.
- Switch the oscilloscope on and check that the pilot lamp on the front panel lights up.
- Check that the current consumption does not exceed 160mA at 220V local mains and 320mA at 117V local mains . (Measured with a moving iron meter).

Supply voltages (Fig. 5.3.).

- Check that the voltage on capacitor C224 is +12V, + or -0,25V; if necessary, readjust potentiometer R204.
- Check the supply voltages in accordance with the following table:

Voltage	Measuring point	Required value	Max. allowable ripple
+5 V	C227	+ 4,8 V to + 5,2 V	2mVp-p
+12V	C224	+11,75V to +12,25V	4mVp-p
- 12V	C229	- 11,75V to - 12,25V	4mVp-p
+38V	C222	+ 37 V to + 39 V	40mVp-p
+6,3V	C211	+5,7 V to +6,9 V	
+180V	C221	+171 V to +189 V	1 Vp-p
-180V	C231	-171 V to -189 V	1 Vp-p

- Vary the a.c. voltage to which the instrument is connected with + or -10% of the nominal voltage.
- Check that the supply voltage does not vary more than 2%.

5.5.2. Cathode-ray tube circuit

Intensity

- Set the controls as indicated in Fig. 4.1.
- Depress X DEFL of S3.
- Set the INTENS control R1 to 90° from its left hand stop.
- Adjust potentiometer R1537 so that the spot is just not visible.
- Turn the INTENS control R1 fully anti-clockwise.

Intens ratio

- Set MTB TIME/DIV switch to 0,2ms/div.
- Set DTB TIME/DIV switch to 0,1ms/div.
- Set the INTENS control R1 to 180° from its left hand stop.
- Check that the MTB trace is just visible; if necessary, readjust potentiometer R1507.

Trace rotation

- Set the TIME/DIV switch to 0,1ms/div.
- Set DTB TIME/DIV switch to OFF
- Centre the time-base line using the A POSITION control R2.
- Check that the time-base line runs exactly in parallel with the horizontal graticule lines; if necessary readjust the front panel TRACE ROTATION potentiometer R13.

Focus and astigmatism

- Set A AMPL/DIV switch to 0,1V/div.
- Set MTB TIME/DIV switch to 50 μ s/div.
- Apply a sine-wave voltage of approx. 600mVp-p, 10kHz to the A input socket X2.
- Set the INTENS control R1 for normal brightness.
- Adjust the FOCUS control R8 for a sharp and well-defined trace over the whole screen area; if necessary, readjust potentiometer R1543 (astigmatism).

Geometrie

- Set MTB TIME/DIV switch to 0,1ms/div.
- Apply a sine-wave voltage of 1,2Vp-p, 10kHz to the channel A-input X2.
- Check that the displayed vertical lines are as straight as possible and that the signal falls between 95x75mm² and 92,3x73,4mm²; if necessary, readjust potentiometer R1549.
- Remove the input signal.

5.5.3. Y-amplifier balance*General information*

The adjustments of the vertical amplifier channels A and B are identical. The knobs, sockets and adjusting elements of channel B are shown in brackets after those of channel A.

D.C. balance

- Set the controls as indicated in Fig. 4.1.
- Depress A (B) of S1.
- Depress O of S18 and S20.
- Centre the trace using the A (B) POSITION control R2 (R3).
- Check that the trace does not jump if AMPL/DIV switch S9 (S11) is rotated; if necessary, readjust potentiometer R504 (R604).

Gain balance

- Depress A (B) of S1.
- Check that the trace does not move when the AMPL/DIV control R9 (R10) is rotated; if necessary, readjust potentiometer R514 (R614).

Normal/invert balance channel B

- Depress B of S1.
- Check that the trace does not jump when PULL TO INVERT switch S5 is switched between normal and invert; if necessary, readjust potentiometer R647.

Shift balance

- Depress A (B) of S1.
- Depress A (B) of S22.
- Set the MTB TIME/DIV switch to 50 μ s/div.
- Release O of S18 and S20.
- Apply a sine-wave voltage of 480mVp-p, 10kHz to the A (B) input socket X2 (X3).
- Check if the extremes of the sine-wave can be displayed distortion free on the screen by rotating the A (B) POSITION control R2 (R3); if necessary; readjust potentiometer R547 (R674).
- Remove the input signal.

5.5.4. Trigger balances

A-balance

- Set the controls as indicated in Fig. 4.1.
- Depress ALT of S1.
- Release S17 and S19 to DC.
- Set the A AMPL/DIV switch and B AMPL/DIV switch to 0,1V/div.
- Set the DTB TIME/DIV switch to 50 μ s/div.
- Depress AC of S2.
- Depress MTB and DTB (=ALT TB) of S3.
- Depress A of S21.
- Turn the TRACE SEPARATION control R14 to its left-hand stop.
- Shift both traces to the central horizontal graticule line, using the A and B position controls R2 and R3.
- Apply a sine-wave voltage of 480mVp-p, 2kHz to both A and B input sockets X2 and X3.
- Depress AC of S4.
- Set the DTB LEVEL control R5 and the MTB LEVEL control R7 in such a way that the DTB and MTB start at a point on the central horizontal graticule line.
- Depress DC of S2.
- Depress DC of S4.
- Check that the starting point of the DTB and MTB is the same as above; if necessary, readjust potentiometers R456 (DTB) and R351 (MTB).

B-balance

- Depress B of S21.
- Depress B of S22.
- Check that the starting point of the DTB and MTB is again the same as above; if necessary, readjust potentiometers R458 (DTB) and R356 (MTB).

Comp.-balance

- Depress A and B (= COMP) of S21.
- Depress A and B (= COMP) of S22.
- Check that the starting point of the DTB and MTB is again the same as above; if necessary, readjust potentiometers R453 (DTB) and R353 (MTB).
- Remove the input signal.

5.5.5. Time-base generators

MTB time-coefficients

- Set the controls as indicated in Fig. 4.1.
- Set the MTB TIME/DIV switch to 1 μ s/div.
- Depress DC of S2.
- Depress MTB of S3.
- Release S17 to DC.
- Apply a time-marker voltage with a repetition time of 1 μ s and an amplitude of 80mVp-p to the A input socket X2.
- Check that the central 8 cycles occupy 8 divisions; if necessary, readjust potentiometer R1417.
- Pull the X MAGN switch S7 to x10.
- Change the repetition time of the applied input signal to 0,1 μ s.
- Check that the central 8 cycles occupy 8 divisions; if necessary, readjust potentiometer R1419.
- Push the X MAGN switch S7 to x1.
- Set the MTB TIME/DIV switch to 1ms/div.
- Change the repetition time of the applied input signal to 1ms.
- Check that the central 8 cycles occupy 8 divisions; if necessary, readjust potentiometer R1216.
- Pull the X MAGN switch S7 to x10.
- Set the MTB TIME/DIV switch to 0,1 μ s/div.
- Change the repetition time of the applied input signal to 10ns.
- Set the X POS control R6 fully clockwise.

- Check that the beginning of the time-base is as linear as possible; if necessary, readjust trimmers C1406 and C1407
- Push the X MAGN switch S7 to x1.
- Check all MTB TIME/DIV switch positions.
The repetition time of the applied input signal should correspond to the position of the MTB TIME/DIV switch. The central 8 cycles should always occupy 8 divisions; tolerance + or - 1 subdivision (2 subdivisions with the X MAGN switch S7 to x10).
- Check that in all the positions of the MTB TIME/DIV switch, the time-base length is at least 10 divisions.
- Check the control range of the MTB TIME/DIV potentiometer R12 in the position 0,2ms/div. of the MTB TIME/DIV switch. The range must be between 1 : 2,6 and 1 : 3,5.

DTB time coefficients

- Turn potentiometer DELAY TIME R4 to its left-hand stop.
- Set the MTB TIME/DIV switch to 2 μ s/div.
- Set the DTB TIME/DIV switch to 1 μ s/div.
- Depress DTB of S3.
- Depress A of S4.
- Apply a time-marker voltage with a repetition time of 1 μ s and an amplitude of 80mVp-p to the A input socket X2.
- Check that the central 8 cycles occupy 8 divisions; if necessary, readjust potentiometer R1336.
- Set the MTB TIME/DIV switch to 0,2ms/div.
- Set the DTB TIME/DIV switch to 0,1ms/div.
- Change the repetition time of the applied input signal to 0,1ms.
- Check that the central 8 cycles occupy 8 divisions; if necessary, readjust potentiometer R1344.
- Check all the other positions of the DTB TIME/DIV switch. The repetition time of the applied input signal should correspond to the position of the DTB TIME/DIV switch. The position of the MTB TIME/DIV switch should be always one step lower.
The central 8 cycles should always occupy 8 divisions: tolerance + or - 1 subdivision.
- Check the control range of the DTB TIME/DIV potentiometer R11 in the position 0,2ms/div. of the DTB TIME/DIV switch. The range must be between 1 : 2,6 and 1 : 3,5.

Delay time multiplier

- Set the MTB TIME/DIV switch to 1 μ s/div.
- Set the DTB TIME/DIV switch to 0,2 μ s/div.
- Depress MTB of S3.
- Depress MTB of S21.
- Apply a time-marker voltage with a repetition time of 1 μ s and an amplitude of 80mVp-p to the A input socket X2.
- Set the DELAY TIME control R4 to 1.00.
- Check that the intensified spot on the trace coincides with the starting point of the second time marker pulse; if necessary, readjust potentiometer R1319.
- Set the DELAY TIME control R4 to 9.00.
- Check that the intensified spot on the trace coincides with the starting point of the tenth time marker pulse; if necessary, readjust potentiometer R1318.
- As both adjustments are slightly interdependent, they must be repeated until both conditions are fulfilled.
- Remove the input signal.

Trace separation

- Set the MTB TIME/DIV switch to 50 μ s/div.
- Set the DTB TIME/DIV switch to 20 μ s/div.
- Depress DTB and MTB (= ALT TB) of S3.
- Set the DELAY TIME control R4 to 1.00.
- Turn the TRACE SEP control R14 fully anti-clockwise.
- Check that the two traces overlap each other.
- Turn the TRACE SEP control R14 fully clockwise.
- Check that the difference between the two traces is at least 3 divisions; if necessary, readjust potentiometer R1420.

Hold off

- Depress MTB of S3
- Set the MTB TIME/DIV switch to $1\mu\text{s}/\text{div}$.
- Set the DTB TIME/DIV switch to OFF.
- Turn the HOLD OFF control R16 fully clockwise.
- Turn the HOLD OFF control slowly anti-clockwise and check that the brightness of the trace decreases. Also check that the starting point of the trace does not change.

5.5.6. Vertical Channels*General Information*

The adjustments of the vertical amplifier channel A and B are identical. The knobs, sockets and adjusting elements of channel A are shown in brackets after those of channel B.

Gain sensitivity x1

- Set the controls as indicated in Fig. 4.1.
- Depress B (A) of S1.
- Release S17 and S19 to DC.
- Set B (A) AMPL/DIV switch to $20\text{mV}/\text{div}$.
- Set MTB TIME/DIV switch to $0,2\text{ms}/\text{div}$.
- Depress B (A) of S22.
- Apply a square-wave voltage of 120mVp-p frequency 2kHz , to the B (A) input socket X3 (X2).
- Check that the signal occupies 6 divisions; if necessary, readjust potentiometer R848 (R543).
- Repeat the measurement for channel A.

Gain sensitivity x10

- Depress B (A) of S1.
- Set B (A) AMPL/DIV switch to $2\text{mV}/\text{div}$.
- Depress B (A) of S22.
- Apply a square-wave voltage of 12mVp-p , frequency 2kHz , to the B (A) input socket X3 (X2).
- Check that the signal occupies 6 divisions; if necessary, readjust potentiometer R621 (R521).
- Repeat the measurement for channel A.

Square-wave response attenuators

- Depress B (A) of S1.
- Set the MTB TIME/DIV switch to $20\mu\text{s}/\text{div}$.
- Depress B (A) of S22.
- Apply a square-wave voltage with an amplitude as indicated in the following table, a frequency of 10kHz and a risetime $\leq 100\text{ns}$ to the B (A) input socket X3 (X2).
- Check that the pulse top errors do not exceed + or - $0,5$ subdivision and that the trace height is 6 divisions + or - $0,5$ subdivision; if necessary, readjust the relevant trimmer.

B (A) Ampl.	YB (YA) input signal	Adjuster
2mV	12mV	
5mV	30mV	
10mV	60mV	
20mV	120mV	C407 (C307)
50mV	300mV	C413 (C313)
0,1V	600mV	C414 (C314)
0,2V	1,2V	C416 + C418 (C316 + C318)
0,5V	3 V	
1 V	6 V	
2 V	12 V	C417 + C419 (C317 + C319)
5 V	30 V	
10 V	60 V	

- Remove the input signal.

Input capacitance

- Apply a square-wave voltage with an amplitude as indicated in the following table, frequency 10kHz and rise time $\leq 100\text{ns}$ to the B (A) input socket X3 (X2) via a dummy probe.

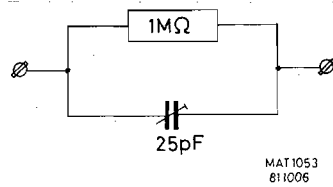

Dummy probe
2 : 1 // 25pF

- Check that the pulse top errors do not exceed + or - 0,5 subdivision and that the trace height is 6 divisions + or - 0,5 subdivision.

B (A) Ampl.	YB (YA) input signal	Adjuster
2mV	24mV	Cv dummy
5mV	60mV	Cv dummy
10mV	120mV	Cv dummy

- Check that the difference in input capacitance do not exceed 1pF.
- Remove the input signal.

Square-wave response final amplifier

- Depress B of S1.
- Set the B AMPL/DIV switch to 20mV/div.
- Depress B of S22.
- Apply a square-wave voltage of 120mVp-p, risetime $\leq 5\text{ns}$ to the B input socket X3. The frequency should be in accordance with the table below.
- Check the square-wave response; pulse top errors may not exceed 0,5 subdivision and the rise time may not exceed 7ns.

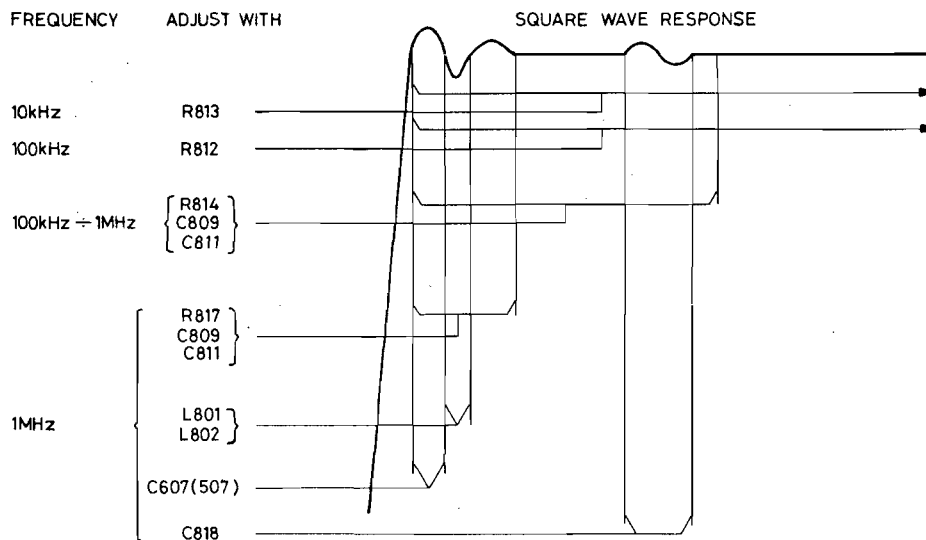

MAT 269

- Check and readjust the square-wave response according to the table below.

Channel	AMPL/DIV	Input signal	Trace height	Rep rate	TIME/DIV	Adj. with	Max. error
B	2mV/div.	12mV	6div.	1MHz	.2 μs	C602	0,5 subdivision
A	20mV/div.	120mV	6div.	1MHz	.2 μs	C508	0,5 subdivision
A	2mV/div.	12mV	6div.	1MHz	.2 μs	C502	0,5 subdivision

Cross talk

- Depress CHOP of S1.
- Set the A and B AMPL/DIV switches to 20mV/div.
- Set the MTB TIME/DIV switch to 0,5ms/div.
- Depress O of S18.
- Depress B of S22.
- Apply a square-wave voltage of 120mVp-p, frequency 10kHz and a risetime ≤ 3 ns to the B input socket X3.
- Check that the crosstalk between both channels is as small as possible; if necessary, readjust potentiometers R812 and R813.
- Remove the input signal.

Bandwidth

- Depress A (B) of S1.
- Set A (B) AMPL/DIV switch to 2mV/div.
- Set MTB TIME/DIV switch to 0,1ms/div.
- Release O of S18 and S20.
- Depress A (B) of S22.
- Apply a sine-wave signal of 12mVp-p, frequency 100kHz and risetime ≤ 3 ns to the A (B) input socket X2 (X3).
- Check that the trace height is 6 div.
- Increase the frequency of the input signal to 50MHz and check that the trace height is at least 4,8 div. at all input frequencies to 50MHz.
- Repeat the measurement for channel B.

Common-mode rejection

- Depress ADD of S1.
- Pull S5 to INVERT
- Set A and B AMPL/DIV switches to 20mV/div.
- Apply a sine-wave signal of 480mVp-p frequency 1MHz to both A and B input sockets X2 and X3.
- Check that the rejection factor is ≥ 100 x.
- Increase the frequency of the input signal to 10MHz.
- Check that the rejector factor is ≥ 50 x.
- Push S5 to NORM.
- Remove the input signal.

Alternate and chopped mode

- Depress ALT of S1.
- Set MTB TIME/DIV switch to 10ms.
- Depress O of S18 and S20.
- Check that the two traces are displayed alternately.
- Depress CHOP of S1.
- Check that the two traces are displayed simultaneously.

5.5.7. Triggering*Trigger sensitivity*

- Set the controls as indicated in Fig. 4.1.
- Depress AC of S2.
- Depress DTB and MTB (= ALT TB) of S3.
- Set MTB TIME/DIV switch to 0,5ms/div.
- Set DTB TIME/DIV switch to 0,2ms/div.
- Depress A of S21.
- Set the TRACE SEP control R14 fully clockwise.
- Apply a sine-wave signal of 14mVp-p, frequency 2kHz to the A input socket X2.
- Set the DTB LEVEL control to its mid-position.
- Check that the MTB trace is triggered; if necessary, readjust potentiometer R1016.
- Check that the DTB trace is triggered; if necessary, readjust potentiometer R1107.

Trigger level internal

- Depress AC of S4.
- Push the MTB and DTB slope switches S8 and S6 to the + position.
- Apply a sine-wave signal of 80mVp-p, frequency 2kHz to the A-input socket X2.
- Check that the traces start with a positive-going edge.
- Pull the MTB and DTB SLOPE switches S8 and S6 to the – position.
- Check that the trace start with a negative-going edge.
- Check that the starting points of the traces move upwards when the MTB and DTB LEVEL controls R7 and R5 are turned clockwise.
Both traces may not be triggered if the MTB and DTB LEVEL controls are set in their both extreme positions.
- Increase the amplitude of the applied input signal to 400mVp-p.
- Check that the both traces are triggered if the LEVEL control R5 is set in their both extreme positions.

Trigger level auto

- Depress MTB of S3.
- Depress AUTO of S4.
- Apply a sine-wave signal for a trace equivalent of 6 divisions, frequency 100Hz to the A input socket X2.
- Check that the starting point of the sine-wave can be shifted across approx. 3 divisions with the aid of the MTB LEVEL control R7.

Trigger level EXT and EXT ÷ 10

- Depress AC of S4.
- Depress EXT of S22.
- Apply a sine-wave signal of 800mVp-p, frequency 2kHz to the A input socket X2 and the EXT input socket X6.
- Check that the starting point of the sine-wave can be shifted across the entire amplitude with the aid of the MTB LEVEL control R7.
- Depress EXT ÷ 10 of S22.
- Increase the input voltage to 8Vp-p.
- Check that the starting point of the sine-wave can be shifted across the entire amplitude with the aid of the MTB LEVEL control R7.

Trigger sensitivity MTB

- Apply a sine-wave signal with a frequency as given in the table below, to the A-input X2; B-input X3 or EXT input X6.
- Adapt the setting of MTB TIME/DIV switch to the frequency of the input signal.
- Check the trigger sensitivities in accordance to the table below.

<i>Signal to</i>	<i>Frequency</i>	<i>S22</i>	<i>S4</i>	<i>Trace height</i>
YA	10 Hz	A	AUTO	≤ 0,7 div.
YA	10 kHz	A	AUTO	≤ 0,7 div.
YA	50 MHz	A	AUTO	≤ 0,8 div.
YA	20 Hz	A	AC	≤ 0,7 div.
YA	50 MHz	A	AC	≤ 0,8 div.
YA	50 MHz	A	DC	≤ 0,8 div.
YB	20 Hz	B	DC	≤ 0,7 div.
YB	50 MHz	B	DC	≤ 0,8 div.
YB	50 MHz	COMP	DC	≤ 0,8 div.
EXT	20 Hz	EXT	DC	≤ 140mV
EXT	50 MHz	EXT	DC	≤ 140mV
EXT	50 MHz	EXT ÷ 10	DC	≤ 1,4V

Trigger sensitivity DTB

- Depress DTB of S3.
- Depress AUTO of S4.
- Apply a sine-wave signal with a frequency as given in the table below, to the A-input X3; B-input X4 or EXT input X5.
- Adapt the setting of MTB and DTB TIME/DIV switches to the frequency of the input signal.
- Check the trigger sensitivities in accordance to the table below.

<i>Signal to</i>	<i>Frequency</i>	<i>S22</i>	<i>S4</i>	<i>Trace height</i>
YA	20 Hz	A	AC	≤ 0,7 div.
YA	50MHz	A	AC	≤ 1,4 div.
YA	50MHz	A	DC	≤ 1,4 div.
YB	20 Hz	B	DC	≤ 0,7 div.
YB	50MHz	B	DC	≤ 1,4 div.
YB	50MHz	COMP	DC	≤ 1,4 div.
EXT	20 Hz	EXT	DC	≤ 140mV
EXT	50MHz	EXT	DC	≤ 180mV

- Remove the input signal.

Line-triggering

- Depress A of S1.
- Depress MTB of S3.
- Depress AUTO of S4.
- Set the A AMPL/DIV switch to 20mV/div.
- Set the MTB TIME/DIV switch to 2ms/div.
- Set the DTB TIME/DIV switch to OFF.
- Release S17 to DC.
- Depress B of S22.
- Apply a mains voltage derived signal of 10mVp-p via a mains transformer to the A input X2.
- Check that the trace is not triggered.
- Depress EXT and EXT ÷ (= LINE) of S22.
- Check that the trace is triggered.
- Remove the input signal.

TV triggering

- Depress AUTO and DC (= TVF) of S4.
- Apply a TV signal with a synchronisation pulse of 14mVp-p to the A input X2.
- Push SLOPE S8 to "+" for a TV signal with positive video.
- Check that a triggered display is visible on the screen.
- Pull SLOPE S8 to "-" for a TV signal with negative video.
- Check that a triggered display is visible on the screen.
- Depress AC and AUTO (= TVL) of S4.
- Set MTB TIME/DIV switch to 10µs/div.
- Check that a triggered display is visible on the screen.

5.5.8. X-Deflection*Sensitivity*

- Set the controls as indicated in Fig. 4.1.
- Depress X DEFL of S3.
- Depress EXT of S22.
- Apply a sine-wave voltage of 1,6Vp-p, frequency 2kHz to the EXT input socket X6.
- Check that the trace length is 8 divisions ± 1 division.
- Remove the input signal.

Bandwidth X-ampl.

- Apply a sine-wave voltage with a frequency of 2kHz to the EXT input socket X6 and adjust the amplitude of the input voltage so that the trace length is 8 divisions.
- Increase the frequency of the input voltage to 1MHz.
- Check that the trace length is at least 5,6 divisions.
- Remove the input signal.

X-Deflection with a line signal

- Depress EXT and EXT ÷ 10 (= LINE) of S22.
- Check that the trace length is ≥ 8 divisions.

Horizontal sensitivity via YA

- Depress B of S1.
- Depress A of S22.
- Apply a sine-wave voltage of 120mVp-p, frequency 2kHz to the A input socket X2.
- Check that the trace length is 6 divisions $\pm 0,6$ division.
- Remove the input signal.

Horizontal sensitivity via YB

- Depress A of S1.
- Depress B of S22.
- Apply a sine-wave voltage of 120mVp-p, frequency 2kHz to the B input socket X3.
- Check that the trace length is 6 divisions $\pm 0,6$ division.

Phase difference between X and Y channels

- Depress B of S1.
- Check that the line is displayed under an angle of 45° with the horizontal central line.
- Increase the frequency of the input to 100kHz.
- Check that the phase error does not exceed 3° (≤ 2 subdivisions).
- Remove the input signal.

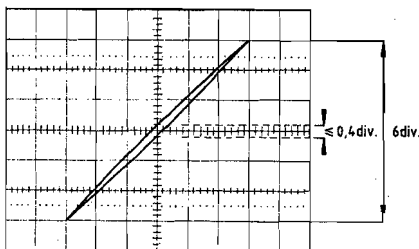

MAT 985

5.5.9. Calibration voltage

- Check that the voltage on the CAL output X1 is a square-wave voltage of 1,2Vp-p $\pm 0,7\%$; if necessary, readjust potentiometer R1607.
- Check that the frequency of the CAL voltage is 2kHz $\pm 10\%$.

6. CORRECTIVE MAINTENANCE

6.1. REPLACEMENTS

WARNING: The opening of covers or removal of parts, except those to which access can be gained by hand, is likely to expose live parts, and also accessible terminals may be live.

The instrument shall be disconnected from all voltage sources before any adjustment, replacement or maintenance and repair during which the instrument will be opened.

If afterwards any adjustment, maintenance or repair of the opened instrument under voltage is inevitable, it shall be carried out only by a qualified person who is aware of the hazard involved. Bear in mind that capacitors inside the instrument may still be charged even if the instrument has been separated from all voltage sources.

Standard parts

Electrical and mechanical replacement parts can be obtained through your local Philips organisation or representative. However, many of the standard electronic components can be obtained from other local suppliers.

Before purchasing or ordering replacement parts, check the parts list for value tolerance, rating and description.

Note: Physical size and shape of a component may affect instrument performance, particularly at high frequencies. Always use direct-replacement components, unless it is known that a substitute will not degrade instrument performance.

Special parts

In addition to the standard electronic components, some special components are used.

These components are manufactured or selected by Philips to meet specific performance requirements.

Transistors and integrated circuits

Transistors and I.C.'s (integrated circuits) should not be replaced unless they are actually defective. If removed from their sockets during routine maintenance return them to their original sockets. Unnecessary replacement or switching of semiconductor devices may affect the calibration of the instrument. When a transistor is replaced, check the operation of the part of the instrument that may be affected.

WARNING: Handle silicone grease with care. Avoid getting silicone grease in the eyes. Wash hands thoroughly after use.

Any replacement component should be of the original type or a direct replacement. Bend the leads to fit the socket and cut the leads to the same length as on the component being replaced.

6.1.1. Replacing internal fuses and mains transformer

- Remove the rear cover and instrument cover as described in chapter 3.2.
- Now three fuses are accessible:
 - Thermal fuse of the mains transformer.
 - Fuse 201 of external battery supply protection.
 - Fuse 202 of power supply protection.

6.1.1.1. Replacing the mains transformer

- Take the lid of the voltage adapter compartment after removing the 4 cross-slotted screws.
- Remove the 4 cross-slotted screws that hold the lid of the transformer compartment.
- Lift the lid with the attached transformer, simultaneously sliding the wire from between transformer and voltage adapter out of the slit in the transformer compartment.
- The transformer is then accessible for replacement.

6.1.1.2 Replacing the thermal fuse

- Remove the mains transformer.
- Unsolder fuse terminals 1 and 2 (Fig. 6.1. and Fig. 6.2.).
- Only the fuse wire of the old fuse is replaced and not the complete fuse; to this end, bend the housing of the fuse slightly outwards, disengage the locking pin and pull out the wire.
- Take the new fuse and remove the fuse wire out of its housing in the same way as described above.
- Push the new fuse wire into the housing of the old one until the locking pin snaps into the hole. The loop in the fuse wire must point to terminal 1.
- Solder the fuse wire to terminals 1 and 2.

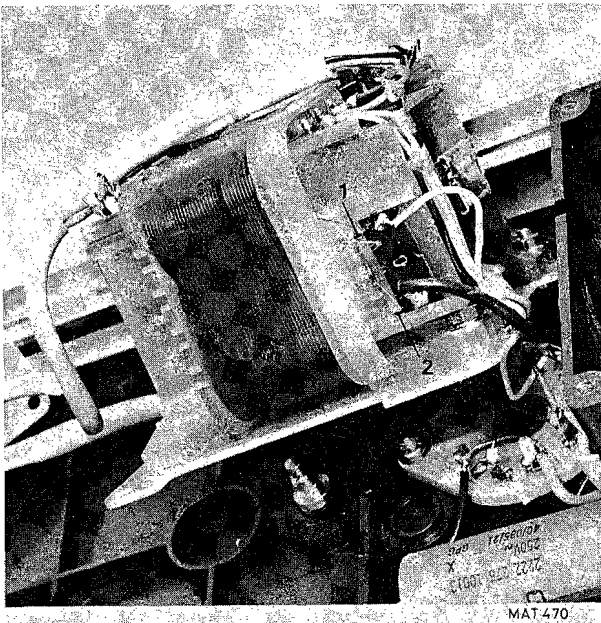

Fig. 6.1.

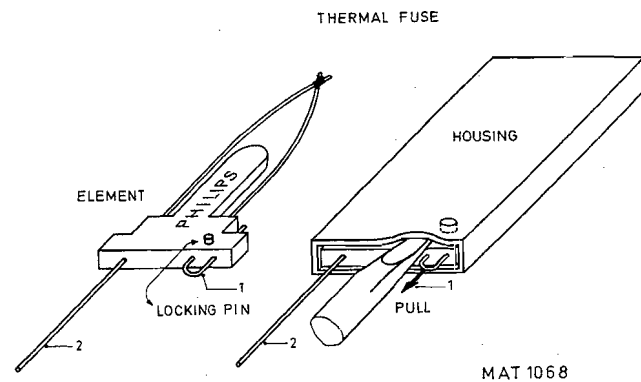

Fig. 6.2.

6.1.1.3. Replacing fuse F201 and F202

These fuses are situated on the power supply unit and can easily be replaced.

6.1.2. Replacing single knobs

- Prise off cap A.
- Slacken screw (or nut) B.
- Pull the knob from the spindle.

When fitting a knob or cap, ensure that the spindle is in a position which allows reference lines to be coincident with the markings on the text plate of the oscilloscope.

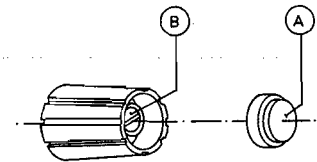

Fig. 6.3.

6.1.3. Replacing double knobs

- Prise off cap A and slacken screw B.
- Pull the inner knob from the spindle.
- Slacken nut C and pull the outer knob from the spindle.

When fitting a knob or cap, ensure that the spindle is in a position which allows reference lines to be coincident with the markings on the text plate of the oscilloscope.

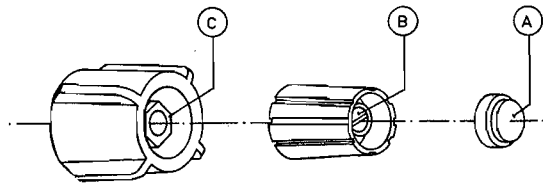
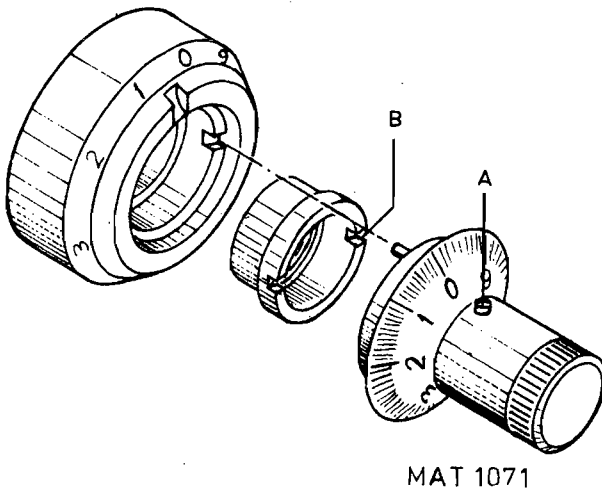

Fig. 6.4.

MAT 163

6.1.4. Replacing the delay-time multiplex knob

- Slacken screw A using an Allen-key and pull the knob of the spindle.
- Remove the nut B and withdraw the ring from the spindle.
- When fitting this control, turn the spindle of the potentiometer fully anticlockwise. Place the ring on the spindle so that the reference line corresponds to the zero mark on the calibrated scale. Then lock it with nut B. Fit the inner knob so that its cam is engaged with the slot in the ring. Rotate the inner knob until its zero mark coincides with the reference line on the ring. Secure the assembly by tightening screw A.



MAT 1071

Fig. 6.5.

6.1.5. Removing the textplate

- After having removed all knobs the textplate can be removed by loosening the four hexaconal nuts of the AMPL/DIV and TIME/DIV switches.

6.1.6. Removing the front assembly

In order to gain access to parts on the AMPL/DIV switches, to replace trimmer capacitors or other components on the attenuator board, it is best to remove the front panel assembly as a whole in accordance with the following procedure:

- Remove the instrument covers in accordance with section 3.2.
- Remove the INTENS, FOCUS and ILLUM knobs by pulling them off the shaft.
- Remove the earthing terminal at the front.
- Remove the two screws C (Fig. 6.7.)
- Remove the four hexagon screws D that secure the pushbutton switches to the front panel (Fig. 6.7.).
- Remove the two screws E that hold the attenuator to the frame bar (Fig. 6.7.).
- Remove the three screws F (Fig. 6.8.).
- Make a note of the positions of the miniature socket connections on the amplifier board.
- Remove all plugs, miniature sockets, coaxial sockets and clamping terminals from the unit and the amplifier board.
- Remove the complete front assembly from the instrument: screening covers can then be removed to gain access to and remove parts.
- Before the pushbutton switches are refitted to the front panel, it is advisable to stick the two parts of each clamping device together by means of adhesive tape or non-hardening glue, in order to facilitate replacement, refer to Fig. 6.9.
- When the front panel assembly is reinstalled, make sure not to interchange the connections of the Y position controls. The connections are correct when the trace shifts upwards if the Y position control is rotated clockwise.

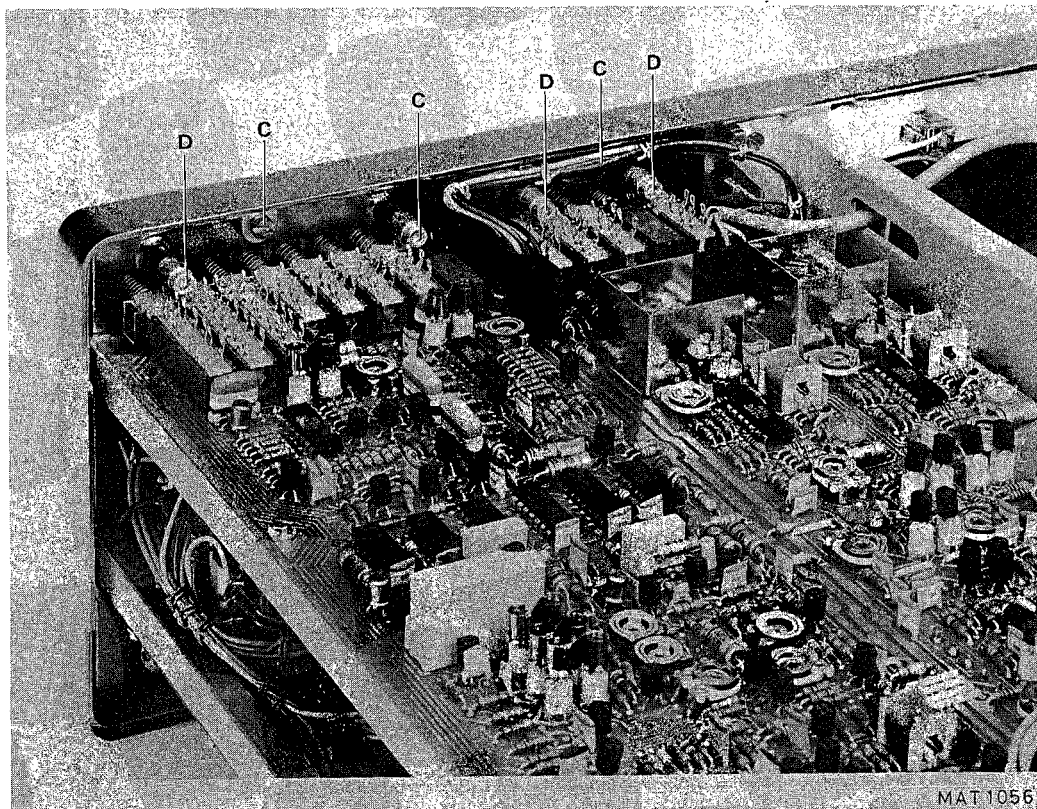
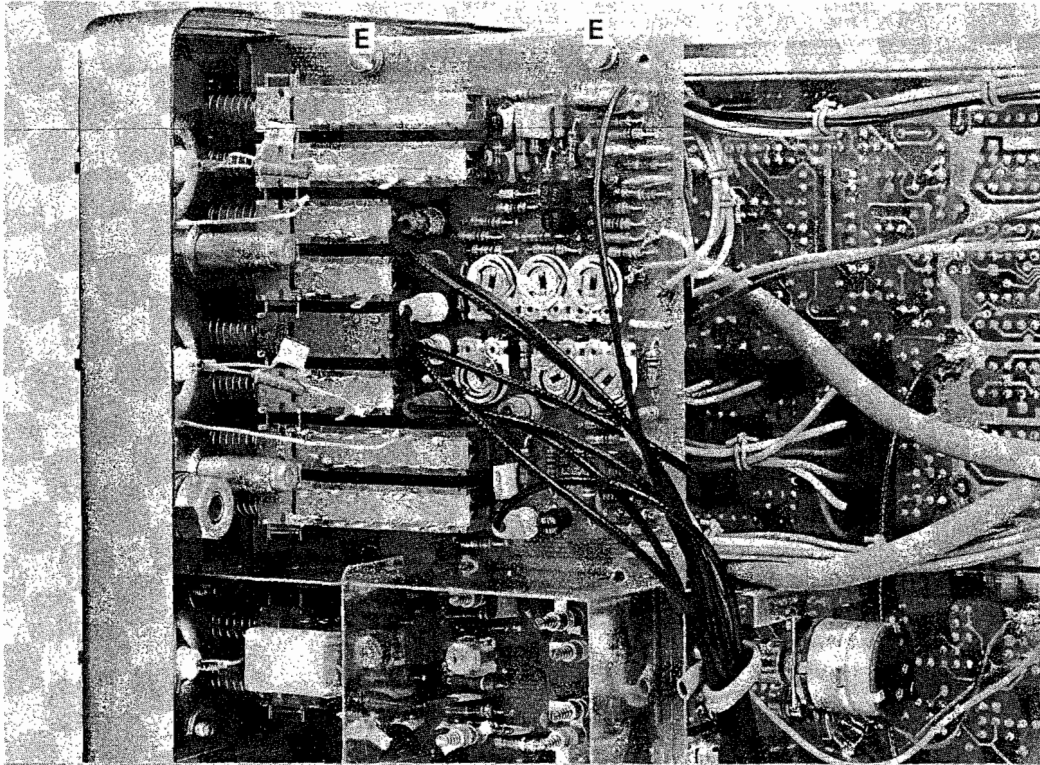
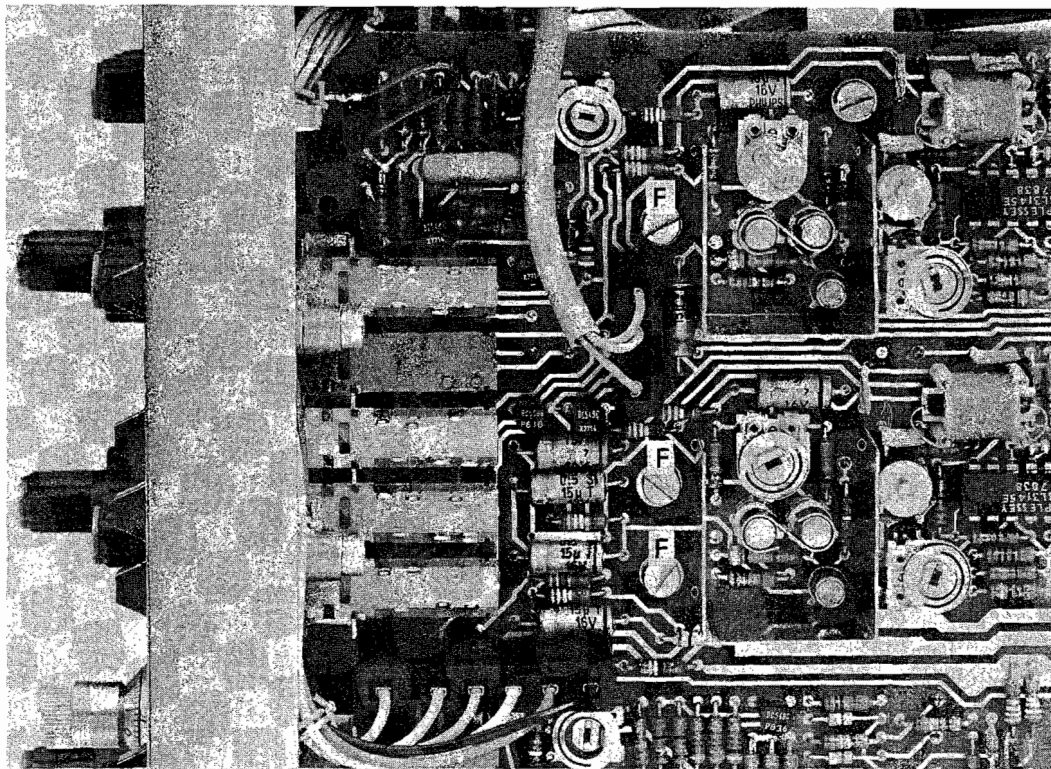

Fig. 6.6. Removing screws C and D



MAT 318

Fig. 6.7. Removing screws E



MAT 319

Fig. 6.8. Removing screws F

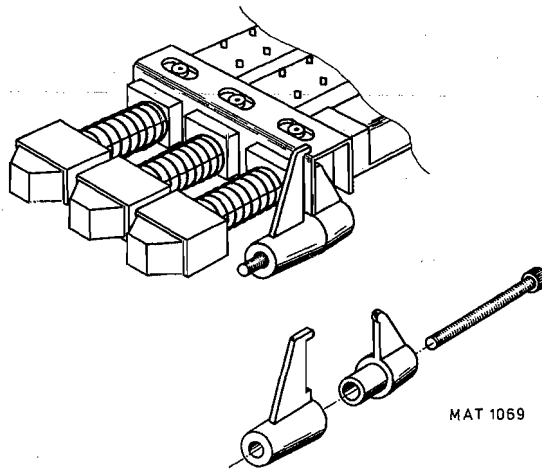

Fig. 6.9.

6.1.7. Replacing switches

6.1.7.1. General

- To replace the AMPL/DIV switches, first remove the front panel assembly (section 6.1.6.)
- To replace the TIME/DIV switch, first remove knobs and text plate (section 6.1.2. – 6.1.5.)
- If one of the pushbutton switches of the main and delayed trigger source selectors (A, B, EXT, MTB or A, B, EXT, LINE) or an input coupling switch (AC/DC 0) must be replaced, it is best to remove the front panel assembly first (section 6.1.6.).
The defective switch is then replaced in accordance with the procedure described below.
- To replace one of the pushbutton switches of the vertical mode switch (A, ALT, CHOP, ADD, B) or the trigger and X deflection mode switch (AC, DC, MTB, X DEFL, AC, AUTO, DC) the amplifier board can be removed if so desired and the defective switch is then replaced as described below.

6.1.7.2. Replacing a switch of a pushbutton unit

- Straighten the 4 retaining lugs of the relevant switch as shown in Fig. 6.10.
- Break the body of the relevant switch by means of a pair of pliers and remove the pieces. The soldering pins are then accessible.
- Remove the soldering pins and clean the holes in the printed-wiring board (e.g. with a suction soldering iron).
- Solder the new switch on to the printed-wiring board.
- Bend the four retaining lugs back to their original positions.

NOTE: The ALT switch and the AC and MTB switch on the delayed time base compartment are dummy switches which can be replaced by a not self-releasing type.

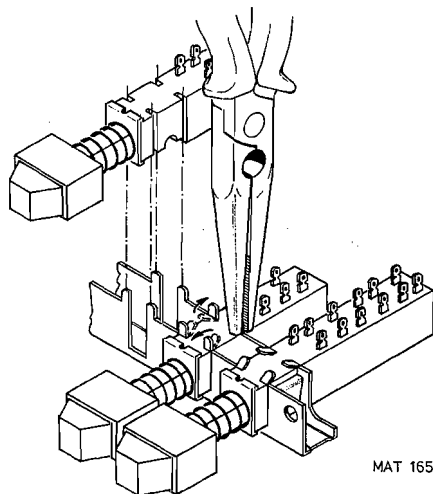

Fig. 6.10.

6.1.8. Replacing the delay line unit

- If there is a defect in the delay line, the complete delay line unit must be replaced.
- Replacement is self-evident, but take care not to interchange the connections at the same end of the delay line; interchange of the connections results in a downward movement of the trace when rotating the POSITION control clockwise.
- Before mounting it must be checked, that the new delay line is placed in its housing like shown in Fig. 6.11.

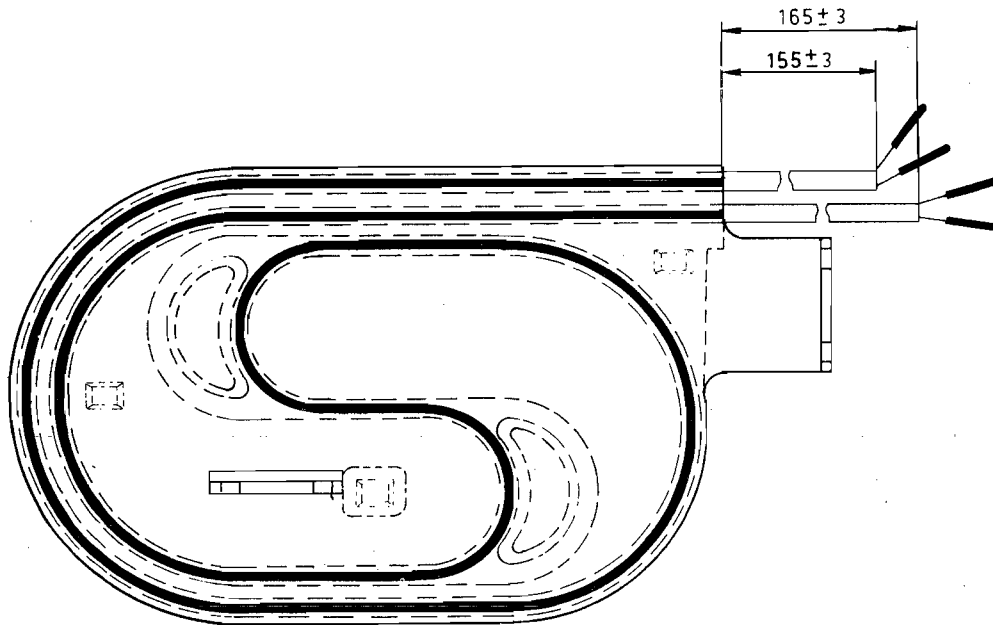

Fig. 6.11.

6.1.9. Replacing the cathode-ray tube

- Remove the instrument covers and rear frame (section 3).
- Remove bezel and contrast plate.
- Unplug the connectors on the c.r.t. neck.
- Ease the base socket off the c.r.t.
- Slacken the brace around the c.r.t. neck.
- Unplug the trace rotation coil connector on the amplifier board and pull cable and plug through the elongated hole in the centre frame.
- Withdraw the c.r.t. through the front panel until the e.h.t. connector at the side of the tube becomes accessible.
- Remove the e.h.t. connector.
- Take the c.r.t. out of the instrument via the front panel; mind the wire and plug of the trace rotation coil.
- Install a c.r.t. in reverse order; position the c.r.t. screen flush with the contrast plate. The torque applied to the screw of the brace around the c.r.t. neck must be between 0,4 and 0,6Nm.

WARNING: Handle the CRT carefully. Rough handling or scratching can cause the CRT to implode. In particular be very careful with the side connections of the CRT. If these pins are bent the CRT is likely to develop a loss of vacuum.

6.2. SOLDERING TECHNIQUES

Working method:

- Carefully unsolder one after the other the soldering tags of the semi-conductor.
- Remove all superfluous soldering material. Use a sucking iron or sucking copper litze wire.
- Check that the tags of the replacement part are clean and pre-tinned on the soldering places.
- Locate the replacement semi-conductor exactly on its place, and solder each tag to the relevant printed conductor on the circuit board.

Note: Bear in mind that the maximum permissible soldering time is 10 seconds during which the temperature of the tags must not exceed 250 deg. C. The use of a solder with a low melting point is therefore recommended.

Take care not damage the plastic encapsulation of the semi-conductor.

TENTION: When you are soldering inside the instrument it is essential to use a low-voltage soldering iron, the tip of which must be earthed to the mass of the oscilloscope.

Suitable soldering irons are:

- ORYX micro-miniature soldering instrument, type 6A, voltage 6 V, in combination with PLATO pin-point tip type 0-569.
- ERSA miniature soldering iron, type minot 040 B, voltage 6 V.
- Low Voltage Mini Soldering Iron, Type 800/12 W - 6 V, power 12 W, voltage 6 V, order no. 4822 395 10004, in combination with 1 mm-pin-point tip, order no. 4822 395 10012.

Ordinary 60/40 solder and 35- to 40-watt pencil-type soldering iron can be used to accomplish the majority of the soldering. If a higher wattage-rating soldering iron is used on the etched circuit boards, excessive heat can cause the etched circuit wiring to separate from the board base material.

6.3. SPECIAL TOOLS

Trimming Tool Kit (Type 800/NTX)

This useful kit contains 3 twin-coloured holders, 2 extension holders and 21 interchangeable trimming pins. The wide variety of pin allows almost every type of trimming function to be carried out in instruments to be calibrated (e.g. measuring instruments, radio and T.V. sets).

Ordering number 4822 310 50015.

(A spare set containing the 8 most commonly used pins is available under the ordering number 4822 310 50016).

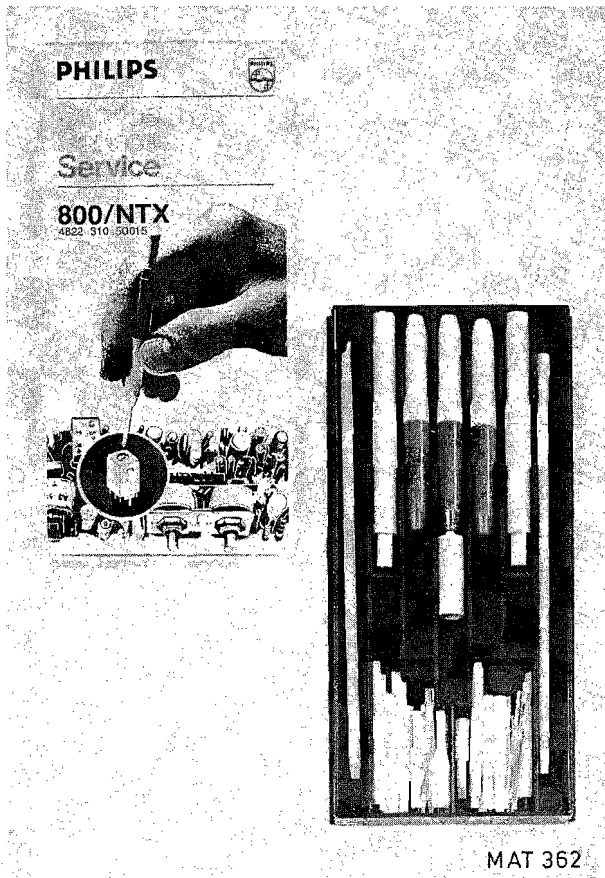

Fig. 6.12.

6.4. RECALIBRATION AFTER REPAIR

After any electrical component has been replaced the calibration of that particular circuit should be checked, as well as the calibration of other closely related circuit.

Since the power supply affects all circuits, calibration of the entire instrument should be checked if work has been done in the power supply or if the transformer has been replaced.

6.5. INSTRUMENT REPACKAGING

If the instrument is to be shipped to a Service Centre for service or repair, attach a tag showing owner (with address) and the name of an individual at your firm that can be contacted. The Service Centre needs the complete instrument serial number and a fault description.

Save and re-use the packing in which your instrument was shipped. If the original packing is unfit for use or not available, repack the instrument in such a way that no damage during transport occurs.

6.6. TROUBLE-SHOOTING

6.6.1. Introduction

The following information is provided to facilitate trouble shooting. Information contained in other sections of this manual should be used along with the following information to aid in locating the defective component. An understanding of the circuit operation is helpful in locating troubles, particularly where integrated circuits are used. Refer to the Circuit Description section for this information.

6.6.2. Trouble-shooting hints

If a fault appears, the following test sequence can be used to find the defective circuit part:

- Check if the settings of the controls of the oscilloscope are correct. Consult the operating instructions in the Operating manual.
- Check the equipment to which the oscilloscope is connected and the interconnection cables.
- Check if the oscilloscope is well-calibrated. If not refer to section 5 (checking and adjusting).
- Visually check the part of the oscilloscope in which the fault is suspected. In this way, it is possible to find faults such as bad soldering connections, bad interconnection plugs and wires, damaged components or transistors and IC's that are not correctly plugged into their sockets.
- Location of the circuit part in which the fault is suspected: the symptom often indicates this part of the circuit. If the power supply is defective the symptom will appear in several circuit parts.

After having carried out the previous steps, individual components in the suspected circuit parts must be examined:

- Transistors and diodes. Check the voltage between base and emitter (0,7Volt approx. in conductive state) and the voltage between collector and emitter (0,2Volt approx. in saturation) with a voltmeter or oscilloscope. When removed from the p.c.b. it is possible to test the transistor with an ohmmeter since the base/emitter and base/collector junctions can be regarded as diodes. Like a normal diode, the resistance is very high in one direction and low in the other direction. When measuring take care that the current from the ohmmeter does not damage the component under test.
Replace the suspected component by a new one if you are sure that the circuit is not in such a condition that the new one will be damaged.
- Integrated circuit. In circuit testing can be done with an oscilloscope or voltmeter. A good knowledge of the circuit part under-test is essential. Therefore first read the circuit description in section 2.
- Capacitors. Leakage can be traced with an ohmmeter adjusted to the highest resistance range. When testing take care of polarity and maximum allowed voltage. An open capacitor can be checked if the response for AC signals is observed. Also a capacitance meter can be used: compare the measured value with value and tolerance indicated in the parts list.
- Resistors. Can be checked with an ohmmeter after having unsoldered one side of the resistor from the p.c.b. Compare the measured value with value and tolerance indicated in the parts list.
- Coils and transformers. An ohmmeter can be used for tracing an open circuit. Shorted or partially shorted windings can be found by checking the wave-form response when HF signals are passed through the circuit. Also an inductance meter can be used.

NOTE: *If a component must be replaced always use a direct-replacement. If not available use an equivalent after carefully checking that it does not degrade the instrument's performance. See also section 6.1. (replacement).*

After replacement of a component the calibration of the instrument may be affected due to component tolerances. If necessary do the required adjustments.

6.6.3. Mains transformer data

The available unloaded voltage tapings and the number of turns per winding are listed in the circuit diagram (Fig. 8.5.) in the form of a table.

6.6.4. Voltages and waveforms in the instrument

The d.c. voltage levels at the electrodes of the transistors and the voltage waveforms in the time-base generator are shown at the relevant points on the circuit diagrams (Fig. 8.5., Fig. 8.6. and Fig. 8.7.)

The oscilloscope under test must be set in the following way to measure the voltage wave-forms as shown in Fig. 8.5. and Fig. 8.6.

- Display mode switch S1 to position "A".
- X deflection selector switch S3 to position "MTB".
- MTB trigger mode switch S4 to position "AUTO".
- A POSITION potentiometer R2 at mid-range
- A AMPL/DIV switch S9 to 1V/div. and potentiometer R9 to CAL.
- Input signal on A input socket X2: 2,5kHz sine-wave voltage for 8 div. deflection.
- X POSITION potentiometer R6 at mid-range.
- X MAGN switch S7 to position "X1".
- MTB LEVEL potentiometer R7 at mid-range.
- DTB LEVEL potentiometer R5 at mid-range.
- MTB SLOPE switch S8 in position "+".
- DTB SLOPE switch S6 in position "+".
- MTB TRIGGER source selector switch S22 to position "A".
- DTB TRIGGER source selector switch S21 to position "A".
- MTB TIME/DIV switch S15 to 0,2ms/div. and potentiometer R12 to CAL.
- DTB TIME/DIV switch S13 to OFF for measuring the diagrams 1-2-3-4-5-6-7-8-9-10-13-14-18a-18b-18d-19a en 19b.
- DTB TIME/DIV switch S13 to 50 μ s/div. for measuring the diagrams 11-12-15-16-17-18c-18e and 19c.

6.7. MAINS VOLTAGE SETTING (PM3217U only)

If the instrument is to be used with 127V, 220V or 240V mains supply, the appropriate voltage should be selected by switching the adaptor on the rear panel until the required voltage is indicated.

If the mains plug has to be adapted, the mains cord must be connected as stated below:

green	: protective earth
black	: phase
white	: neutral

6.8. CHECKS AFTER REPAIR AND MAINTENANCE.

6.8.1. Checking the protective leads.

The correct connection and condition is checked by visual control and by measuring the resistance between the protective-lead connection at the plug and the cabinet.

The resistance should be $< 0,5\Omega$. During measurement the mains cable should be moved. Resistance variations indicate a defect.

6.8.2. Checking the insulating resistance.

Measure the insulating resistance at $U_{dc} = 500V$ between the mains connections and the protective lead connections. For this purpose set the mains switch to ON. The insulating resistance should be $> 2M\Omega$.

6.9. EXTRA IN- AND OUTPUT CIRCUITS

The PM 3217 is equipped with Z-mod input mounted at the rear panel and with facilities to add two extra output circuits with a minimum of components. The in- and output BNC sockets are mounted in the holes above the c.r.t. socket; only 15-mm-holes must be drilled in the plastic rear cover (Fig. 6.13.) on the positions as indicated.

6.9.1. External Z-modulation input

Characteristics

- TTL Compatible
- Current drain at 0 V: -3 mA; at +5 V: +1 mA
- Brightness: light from +2 V to +7 V maximum
dark from +0.8 V to -1.2 V minimum
- Rise time from light to dark and vice versa: 50 ns
- Delay time from input socket to screen: 85 ns

Used components

– Coax. cable (per metre)	5322 320 10003
– BNC connector	5322 267 10004
– Filler ring for BNC connector	5322 532 24319
– Nut for BNC connector	5322 506 14001
– Solder tag	5322 290 34022

6.9.2. Main time base sweep output

Characteristics

- Output voltage: minimum level $-1,8$ V
maximum level $+3,8$ V \pm 0,5 V
- Internal resistance: 1 kohm
- The output is protected against short-circuits

Required components

– Coax. cable (per metre)	5322 320 10003
– BNC connector	5322 267 10004
– Filler ring for BNC connector	5322 532 24319
– Nut for BNC connector	5322 506 14001
– Resistor 1 kohm	5322 116 54549
– Resistor 1,27 kohm	5322 116 50555
– Transistor BC548C	5322 130 44196
– Solder tag	5322 290 34022

Fitting the output

- Fit the BNC connector as described in section 6.9.
- Fit the resistors as indicated in Fig. 6.14.
- Fit the transistor as indicated in Fig. 6.14.

- Connect one end of the coaxial cable to the points indicated in Fig. 6.14. and the other end to the BNC connector.
- Make sure that the coaxial cable is also earthed at the BNC connector end.

6.9.3. Main time base gate output

Characteristics

- Output voltage: high level more than +2,7 V
low level less than 0,5 V
- TTL output.
- The output is protected against short-circuits.

Required components

- | | |
|---------------------------------|----------------|
| – Coax. cable (per metre) | 5322 320 10003 |
| – BNC connector | 5322 267 10004 |
| – Filler ring for BNC connector | 5322 532 24319 |
| – Nut for BNC connector | 5322 506 14001 |
| – Solder tag | 5322 290 34022 |

Fitting the output

- Fit the BNC connector as described in section 6.9
- Connect one end of the coaxial cable to the points indicated in Fig. 6.14. and the other end to the BNC connector.
- Make sure that the coaxial cable is also earthed at the BNC connector end.

6.9.4. Delayed time base gate output

Characteristics

- Output voltage: high level more than +2,7 V
low level less than 0,5 V
- TTL output.
- The output is protected against short-circuits.

Required components

- | | |
|---------------------------------|----------------|
| – Coax. cable (per metre) | 5322 320 10003 |
| – BNC connector | 5322 267 10004 |
| – Filler ring for BNC connector | 5322 532 24319 |
| – Nut for BNC connector | 5322 506 14001 |
| – Solder tag | 5322 290 34022 |

Fitting the output

- Fit the BNC connector as described in section 6.9.
- Connect one end of the coaxial cable to the points indicated in Fig. 6.14. and the other end to the BNC connector.
- Make sure that the coaxial cable is also earthed at the BNC connector end.

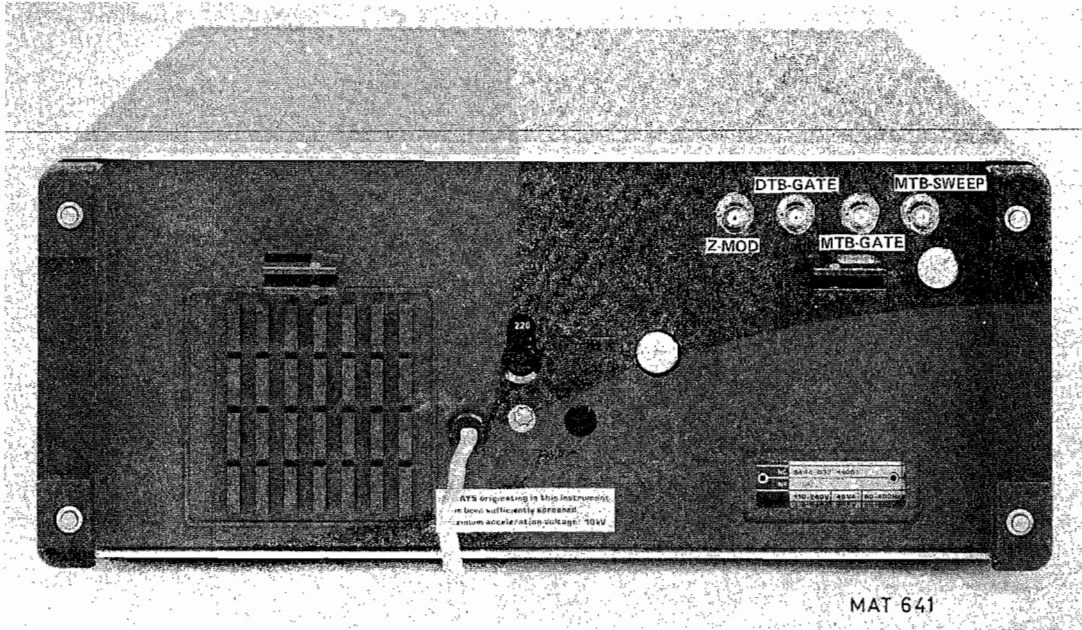

Fig. 6.15. Rear view of the oscilloscope

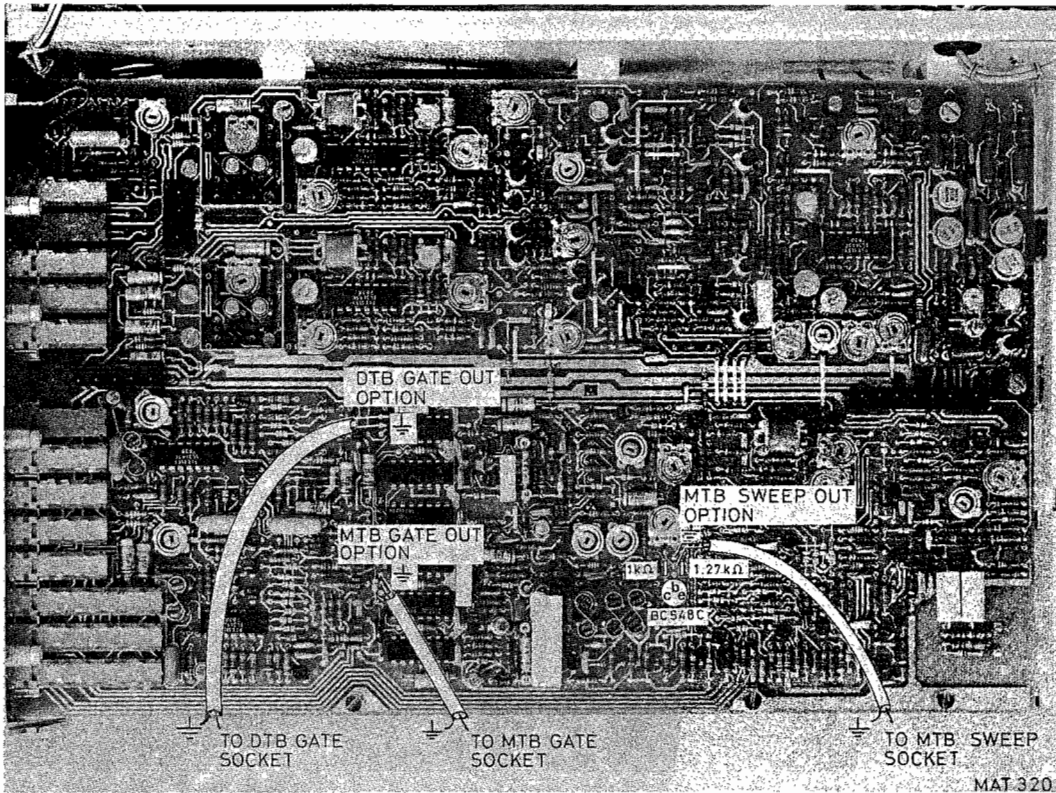

Fig. 6.16. Mounting the components and the cables

6.10. ACCESSORY INFORMATION

Dismantling

Dismantling the probe (see Fig. 6.17.)

The front part 11 of the probe can be screwed from the rear part 13. Item 11 can then be slid from 12 and 13. The RC combination 12 is soldered to 13. For replacement of 12 refer to the next section.

Dismantling the compensation box (see Fig. 6.17.)

Unscrew the ribbed collar of the compensation box to the cable. The case 14 can then be slid sideways off the compensation box. The electrical components on the printed-wiring board are then accessible.

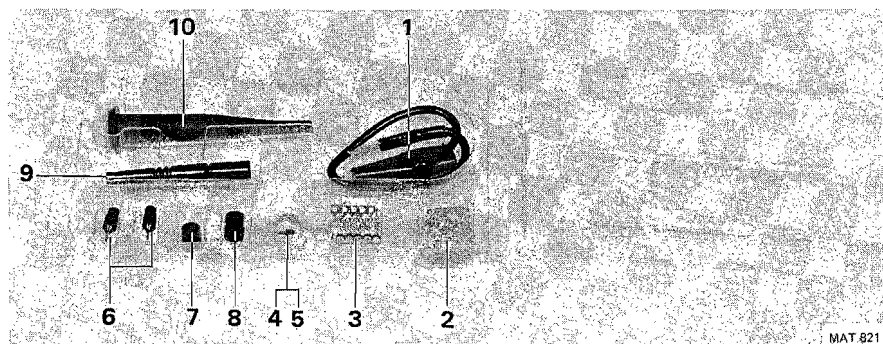
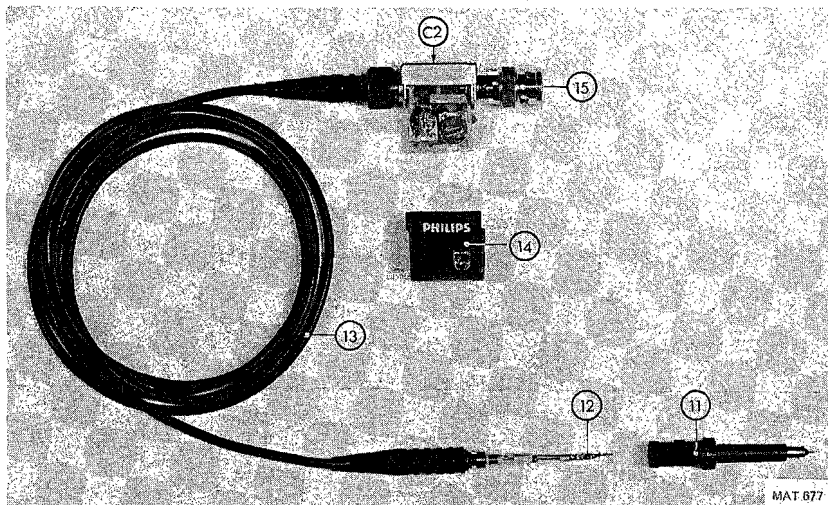

Fig. 6.17.

Replacing parts

Assembling the probe

A new RC network is slid over the cable nipple, after which the cable core is soldered on to the resistor wire. When a measuring probe is assembled, the RC network must be at dead centre in the probe tip.

Replacing the cable assembly

Dismantle the compensation box.

Unsolder the connection between the inner conductor and the printed-wiring board. Keep the frame of the compensation box steady and loosen the cable nipple with a 5 mm spanner on the hexagonal part. Replace the cable and fit it, working in the reverse order.

Replacing the BNC

Dismantle the compensation box.

Unsolder the connection to the printed-wiring board. Hold the frame of the compensation box firmly and loosen the BNC with a 3/8 inch spanner. Replace the BNC and fit it, working in the reverse order.

Replacing the probe tip

The damaged tip can be pulled out by means of a pair of pliers. A new tip must be firmly pushed in.

Parts list

Mechanical parts (see Fig. 6.17. and Fig. 6.18.)

Items 1 to 10 are standard accessories supplied with the probe.

Item	Order number	Qty	Description
1	5322 321 20223	1	Earth cable
2	5322 256 94136	1	Probe holder
3	5322 255 44026	10	Soldering terminals which may be incorporated in circuits as routine test points
4	5322 532 64223	2	Marking ring red
5	5322 532 64224	2	Marking ring white
	5322 532 64225	2	Marking ring blue (not shown)
6	5322 268 14017	2	Probe tip
7	5322 462 44319	1	Insulating cap to cover metal part of probe during measurements in densely wired circuits
8	5322 462 44318	2	Cap facilitating measurements on dual-in-line integrated circuits
9	5322 264 24018	1	Wrap pin adaptor
10	5322 264 24019	1	Spring-loaded test clip
11	5322 264 24021	1	Probe shell with check-zero button
12	5322 216 54152	1	RC network
13	5322 320 14063	1	Cable assembly
14	5322 447 64016	1	Cap
15	5322 268 44019	1	BNC connector

Electrical parts

Item	Order number	Description
C1	—	Part of RC network (not supplied separately)
C2	5322 125 54003	Trimmer 60 pF, 300 V
R1	—	Part of RC network (not supplied separately)
R2	5322 101 14047	Potmeter 470 Ω , 20 %, 0.5 W
R3	5322 100 10112	Potmeter 1 k Ω , 20 %, 0.5 W

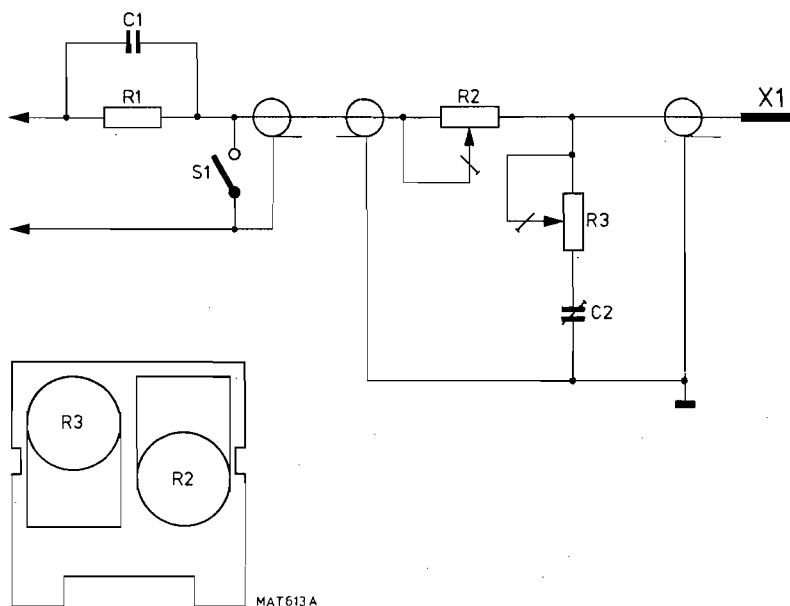

Fig. 6.18.



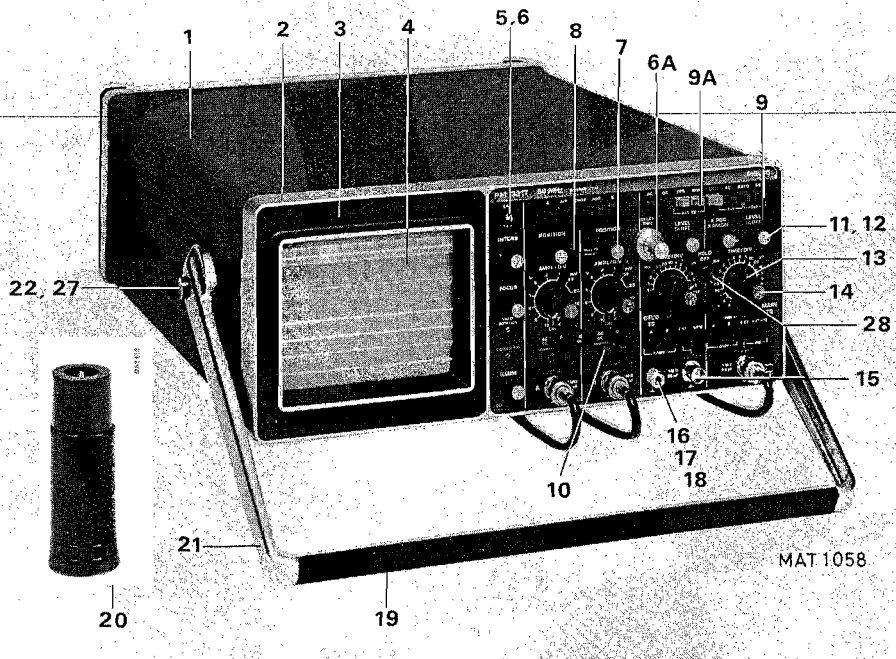

Fig. 7.1. Front view showing item numbers

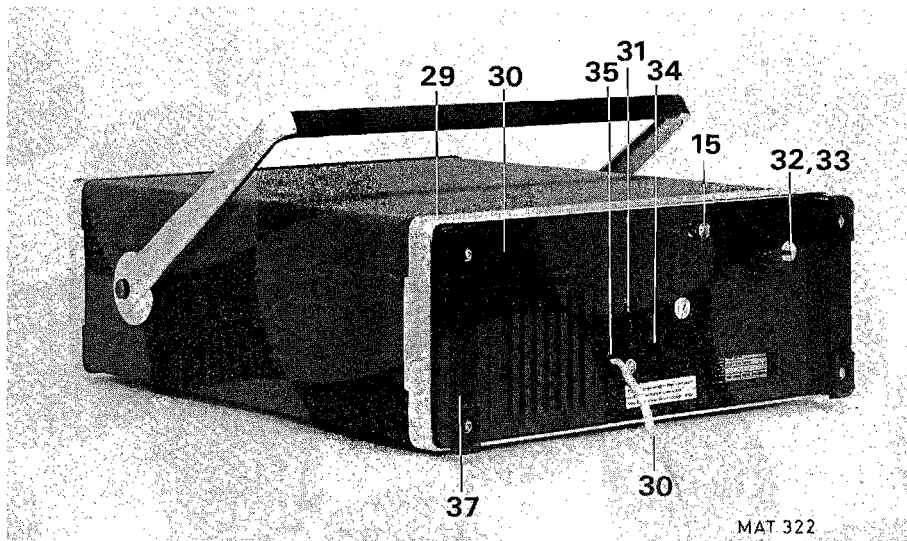

Fig. 7.2. Rear view showing item numbers

7. PARTS LISTS (Subject to alteration without notice)

7.1. Mechanical Parts

Figure 7.1.

<i>Item</i>	<i>Qty</i>	<i>Order number</i>	<i>Designation</i>
1	1	5322 447 94399	Cabinet without handle
2	1	5322 447 94401	Cast aluminium front frame
3	1	5322 450 74009	Bezel
4	1	5322 480 34074	Contrast filter blue
5	1	5322 264 24015	Calibration terminal
6	1	5322 325 84013	Grommet for calibration terminal
6A	1	5322 414 34147	Counter knob
7	2	5322 414 34091	Knob
8	1	5322 456 90013 5322 456 90014	Textplate PM 3217 Textplate PM 3217U
9	20	5322 414 14011	Knob for push-button switch, dark grey
9A	3	5322 414 26019	Knob for push-button switch, light grey
10	2	5322 414 25613	Knob for push-button switch, green
11	10	5322 414 34134	Knob
12	9	5322 414 74015	Knob cover grey
13	4	5322 414 34079	Knob
14	4	5322 414 74029	Knob cover blue
15	4	5322 267 10004	BNC connector
16	1	5322 535 84346	Earthing terminal
17	1	5322 505 14178	Knurled nut for earthing terminal
18	1	5322 506 14005	Hexagonal nut for earthing terminal
19	1	5322 498 54077	Grip
20	1	5322 263 24005	BNC-4 mm adapter
21	2	5322 498 54072	Bracket
22	2	5322 520 14267	Bearing bush
23	2	5322 528 34128	Ratchet
24	2	5322 530 84075	Spring
25	2	5322 414 64053	Knob
26	2	4822 502 30054	Screw
27	2	4822 532 10582	Washer
28	2	5322 414 34217	Knob
	2	5322 492 64327	Spring

Figure 7.2.

29	1	5322 447 94402	Cast aluminium rear frame
30	1	5322 447 94404	Rear panel
31	1	4822 272 10079	Line voltage adapter
32	2	5322 500 14228	Coin slot screw
33	2	4822 530 70126	Circlip
34	1	4822 265 20051	D.C. Power input connector
35	1	5322 325 50101	Line cable cleat
36	1	4822 321 10084	Line cable, European type
		4822 321 10092	Line cable, U.S.A. type
37	2	5322 462 44298	Foot (rear panel)

<i>Item</i>	<i>Qty</i>	<i>Order number</i>	<i>Designation</i>
<i>Not shown</i>			
38	5	5322 276 14102	Self-releasing push-button segment
39	19	5322 276 14117	Mutual-releasing push-button
40	1	5322 255 44088	LED holder
41	2	5322 255 24015	Lamp holder
42	4	5322 462 44297	Foot (cabinet)
43	1	4822 266 20014	D.C. Power input plug
44	1	4822 321 20125	D.C. Power input cord set
45	1	5322 447 94403	Front cover

7.1.1. Spare parts for pushbutton switches

- Dual change over switch with spring for use with a reset bar.
Ordering number 5322 276 14101
In each instrument there are 14 pieces.
- Dual change over switch with spring for use with reset bar (push on - push off function).
Ordering number 5322 276 14117.
In each instrument there are 4 pieces.
- Four change over switch with spring for use with a reset bar.
Ordering number 5322 276 14102.
In each instrument there are 7 pieces.
- Reset bar for max. 6 switches.
The bar can be used for max. 6 switches that have a distance of 10,16mm. from each other.
When the bar is needed for a unit with e.g. four switches it must be sawn to the required size.
When doing this take care that the distance between the last stud and the end of the bar is exactly 4,1mm.
When one switch in a unit needs no reset bar (e.g. an independent switch such as "erase" then remove at the relevant spot the stud from the bar with a pair of pincers.
The spring for the reset bar will be delivered together with the switch segments.
Ordering number 5322 278 74007.
In each instrument are 5 pieces.
- Support for max. 11 switches
The supports can be sawn to the required size.
Ordering number:
Max. 11 switches : 5322 466 85843 Notch distances 10 x 10,16mm.
In each instrument there are 5 pieces.

7.2. ELECTRICAL PARTS

CAPACITORS

POSNR	DESCRIPTION		ORDERING CODE
C 101	220 NF 10%	275V	5322 121 06001
C 200	100NF 10%	250V	4822 121 41161
C 201	22NF-20+80	40	4822 122 30103
C 202	680NF 10%	100V	4822 121 40443
C 203	4700UF-10+50	40	4822 124 70226
C 204	100NF 10%	250V	4822 121 41161
C 206	3,3UF-10+50	63	4822 124 20725
C 207	680NF 10%	100V	4822 121 40443
C 208	47UF-10+50	25	4822 124 20699
C 211	68UF-10+50	6,3	4822 124 20671
C 218	22NF 10%	1600V	4822 121 40196
C 219	22NF 10%	1600V	4822 121 40196
C 221	4UF-10+50	250	4822 124 20316
C 222	100UF-10+50	40	4822 124 20715
C 223	33UF-10+50	16	4822 124 20688
C 224	220UF-10+50	16	4822 124 20693
C 226	68UF-10+50	6,3	4822 124 20671
C 227	470UF-10+50	6,3	4822 124 20673
C 228	33UF-10+50	16	4822 124 20688
C 229	220UF-10+50	16	4822 124 20693
C 231	4UF-10+50	250	4822 124 20316
C 251	15UF-10+50	16	4822 124 20687
C 252	15UF-10+50	16	4822 124 20687
C 253	15UF-10+50	16	4822 124 20687
C 254	15UF-10+50	16	4822 124 20687
C 255	22NF-20+80	40	4822 122 30103
C 256	22NF-20+80	40	4822 122 30103
C 257	15UF-10+50	16	4822 124 20687
C 258	15UF-10+50	16	4822 124 20687
C 259	15UF-10+50	16	4822 124 20687
C 261	22NF-20+80	40	4822 122 30103
C 262	22NF-20+80	40	4822 122 30103
C 263	22NF-20+80	40	4822 122 30103
C 266	15UF-10+50	40	4822 124 20709
C 267	15UF-10+50	16	4822 124 20687
C 268	22NF-20+80	40	4822 122 30103
C 269	15UF-10+50	16	4822 124 20687
C 271	22NF-20+80	40	4822 122 30103
C 272	33UF-10+50	6,3	4822 124 20669
C 273	15UF-10+50	16	4822 124 20687
C 274	15UF-10+50	16	4822 124 20687
C 275	22NF-20+80	40	4822 122 30103
C 276	22NF-20+80	40	4822 122 30103
C 277	22NF-20+80	40	4822 122 30103
C 278	15UF-10+50	16	4822 124 20687
C 279	15UF-10+50	16	4822 124 20687
C 280	22NF-20+80	40	4822 122 30103
C 281	15UF-10+50	16	4822 124 20687
C 282	22NF-20+80	40	4822 122 30103
C 283	22NF-20+80	40	4822 122 30103
C 284	100NF 10%	250V	4822 121 41161
C 285	22NF-20+80	40	4822 122 30103
C 286	100NF 10%	250V	4822 121 41161
C 301	100NF 10%	400V	4822 121 40012

POSNR	DESCRIPTION	ORDERING CODE
C 305	47PF 2 500	4822 122 31072
C 307	18PF	5322 125 50051
C 308	47PF 2 500	4822 122 31072
C 309	15PF 2 500	4822 122 31197
C 310	15PF 2 500	4822 122 31197
C 311	12PF 2 500	4822 122 31196
C 312	3,9PF 0,25PF 500	4822 122 31217
C 313	5,5PF	5322 125 54027
C 314	5,5PF	5322 125 54027
C 315	1,5PF 0,25PF 500	4822 122 31184
C 316	3PF	5322 125 54026
C 317	3PF	5322 125 54026
C 318	3PF	5322 125 54026
C 319	3PF	5322 125 54026
C 320	3,3PF 0,25PF 500	4822 122 31188
C 321	27PF 2 100	4822 122 30045
C 322	120PF 2 100	4822 122 31348
C 324	120PF 2 100	4822 122 31348
C 351	33PF 2 500	4822 122 31202
C 353	22NF-20+80 40	4822 122 30103
C 354	15PF 2 500	4822 122 31197
C 356	150NF 10% 100V	4822 121 40423
C 357	18PF 2 500	4822 122 31198
C 358	150PF 2 100	4822 122 31413
C 359	2,2PF 0,25PF 100	4822 122 31036
C 401	100NF 10% 400V	4822 121 40012
C 405	47PF 2 500	4822 122 31072
C 407	18PF	5322 125 50051
C 408	47PF 2 500	4822 122 31072
C 409	15PF 2 500	4822 122 31197
C 410	15PF 2 500	4822 122 31197
C 411	12PF 2 500	4822 122 31196
C 412	3,9PF 0,25PF 500	4822 122 31217
C 413	5,5PF	5322 125 54027
C 414	5,5PF	5322 125 54027
C 415	1,5PF 0,25PF 500	4822 122 31184
C 416	3PF	5322 125 54026
C 417	3PF	5322 125 54026
C 418	3PF	5322 125 54026
C 419	3PF	5322 125 54026
C 420	3,3PF 0,25PF 500	4822 122 31188
C 421	27PF 2 100	4822 122 30045
C 422	120PF 2 100	4822 122 31348
C 424	120PF 2 100	4822 122 31348
C 451	39PF 2 500	4822 122 31203
C 452	8,2PF 0,25PF 500	4822 122 31194
C 453	1PF 0,25PF 100	4822 122 30104
C 501	33PF 2 100	4822 122 31067
C 502	20PF	4822 125 50045
C 503	180PF 2 100	4822 122 31352
C 504	3,9PF 0,25PF 100	5322 122 34107
C 507	3,5PF	5322 125 50048
C 509	22NF-20+80 40	4822 122 30103
C 510	33PF 2 100	4822 122 31067
C 511	10PF 2 100	4822 122 31054
C 513	22NF-20+80 40	4822 122 30103
C 517	22NF-20+80 40	4822 122 30103
C 518	22NF-20+80 40	4822 122 30103
C 519	22NF-20+80 40	4822 122 30103
C 520	22NF-20+80 40	4822 122 30103
C 521	22NF-20+80 40	4822 122 30103

POSNR	DESCRIPTION	ORDERING	CODE
C 522	150PF 2	100	4822 122 31085
C 523	22NF-20+80	40	4822 122 30103
C 601	33PF 2	100	4822 122 31067
C 602	20PF		4822 125 50045
C 603	180PF 2	100	4822 122 31352
C 604	3,9PF 0,25PF	100	5322 122 34107
C 607	3,5PF		5322 125 50048
C 609	22NF-20+80	40	4822 122 30103
C 610	33PF 2	100	4822 122 31067
C 611	10PF 2	100	4822 122 31054
C 613	22NF-20+80	40	4822 122 30103
C 616	22NF-20+80	40	4822 122 30103
C 617	22NF-20+80	40	4822 122 30103
C 618	22NF-20+80	40	4822 122 30103
C 619	22NF-20+80	40	4822 122 30103
C 620	22NF-20+80	40	4822 122 30103
C 621	22NF-20+80	40	4822 122 30103
C 622	150PF 2	100	4822 122 31085
C 623	22NF-20+80	40	4822 122 30103
C 701	22NF-20+80	40	4822 122 30103
C 702	270PF 10	100	4822 122 30095
C 704	2,7NF 10	100	4822 122 30057
C 705	4,7NF-20+80	40	4822 122 31125
C 706	22NF-20+80	40	4822 122 30103
C 707	22NF-20+80	40	4822 122 30103
C 801	22NF-20+80	40	4822 122 30103
C 802	18PF 2	100	4822 122 31061
C 803	10NF 630V		4822 121 41134
C 804	180PF 2	100	4822 122 31352
C 805	0,56PF 0,25PF	100	5322 122 34039
C 806	1NF 10	100	4822 122 30027
C 807	56PF 2	100	4822 122 31521
C 808	82PF 2	100	4822 122 31243
C 809	40PF		4822 125 50092
C 810	0,56PF 0,25PF	100	5322 122 34039
C 811	40PF		4822 125 50092
C 812	33PF 2	100	4822 122 31067
C 813	22NF-20+80	40	4822 122 30103
C 815	22NF-20+80	40	4822 122 30103
C 817	0,56PF 0,25PF	100	5322 122 34039
C 818	3,5PF		5322 125 50048
C 819	22PF 2	100	4822 122 31063
C 821	22NF-20+80	40	4822 122 30103
C 1001	220NF 10%	100V	4822 121 40427
C 1002	470NF 10%	100V	4822 121 40438
C 1003	470NF 10%	100V	4822 121 40438
C 1004	22NF-20+80	40	4822 122 30103
C 1005	3,9PF 0,25PF	100	5322 122 34107
C 1006	15UF-10+50	16	4822 124 20687
C 1007	22NF-20+80	40	4822 122 30103
C 1008	0,56PF 0,25PF	100	5322 122 34039
C 1009	4,7NF 10	100	4822 122 30128
C 101	330NF 20%	250V	5322 121 44189
C 1011	4,7NF 10	100	4822 122 30128
C 1012	3,9NF 10	100	4822 122 30098
C 1101	220NF 10%	100V	4822 121 40427
C 1102	22NF-20+80	40	4822 122 30103
C 1103	22NF-20+80	40	4822 122 30103
C 1104	0,56PF 0,25PF	100	5322 122 34039
C 1105	22NF-20+80	40	4822 122 30103
C 1106	22NF-20+80	40	4822 122 30103
C 1107	22NF-20+80	40	4822 122 30103
C 1201	47UF-10+50	25	4822 124 20699
C 1202	22NF-20+80	40	4822 122 30103
C 1203	2.4NF 1%	63V	5322 121 54054

POSNR	DESCRIPTION		ORDERING	CODE
C 1204	15NF 10%	630V	5322 121	40324
C 1205	390PF 2	100	4822 122	31426
C 1206	2.2UF 5%	100V	5322 121	44246
C 1207	4,7UF-10+50	63	5322 124	24211
C 1208	1NF 10	100	4822 122	30027
C 1209	22NF-20+80	40	4822 122	30103
C 1210	4,7UF 50%	16V	4822 124	20686
C 1211	56PF 2	100	4822 122	31521
C 1212	22PF 2	100	4822 122	31063
C 1301	0,56PF 0,25PF	100	5322 122	34039
C 1302	1.1NF	630V	5322 121	54134
C 1303	150NF 10%	100V	5322 121	40323
C 1304	1NF 10	100	4822 122	30027
C 1305	22NF-20+80	40	4822 122	30103
C 1306	22NF-20+80	40	4822 122	30103
C 1307	33UF-10+50	6,3	4822 124	20669
C 1308	22NF-20+80	40	4822 122	30103
C 1309	22NF-20+80	40	4822 122	30103
C 1310	22NF-20+80	40	4822 122	30103
C 1311	22NF-20+80	40	4822 122	30103
C 1312	22NF-20+80	40	4822 122	30103
C 1314	22NF-20+80	40	4822 122	30103
C 1315	470PF 10	100	4822 122	30034
C 1316	22NF-20+80	40	4822 122	30103
C 1402	1NF 10	100	4822 122	30027
C 1404	0,56PF 0,25PF	100	5322 122	34039
C 1405	220NF 10%	100V	4822 121	40427
C 1406	3,5PF		5322 125	50048
C 1407	3,5PF		5322 125	50048
C 1408	0,56PF 0,25PF	100	5322 122	34039
C 1409	22NF-20+80	40	4822 122	30103
C 1411	22NF-20+80	40	4822 122	30103
C 1412	22NF-20+80	40	4822 122	30103
C 1413	22NF 10%	250V	4822 121	40407
C 1414	22NF 10%	250V	4822 121	40407
C 1416	100NF 10%	250V	4822 121	41161
C 1417	100NF 10%	250V	4822 121	41161
C 1501	22NF-20+80	40	4822 122	30103
C 1502	22NF-20+80	40	4822 122	30103
C 1503	1PF 0,25PF	100	4822 122	30104
C 1504	10NF-20+80	40	4822 122	30043
C 1506	4,7NF 10	100	4822 122	30128
C 1507	4,7NF 10	100	4822 122	30128
C 1508	1,5NF 10%	1600V	4822 121	40354
C 1509	22NF-20+80	40	4822 122	30103
C 1511	1,5NF 10%	1600V	4822 121	40354
C 1512	1,5NF 10%	1600V	4822 121	40354
C 1513	22PF 2	100	4822 122	31063
C 1601	330NF 10%	100V	4822 121	40434
C 1602	47PF 2	100	4822 122	31072
C 1651	68PF 2	100	4822 122	31349
C 1652	82PF 2	100	4822 122	31243
C 1653	27PF 2	100	4822 122	30045
C 1654	33PF 2	100	5322 122	31556
C 1655	100PF 2	100	4822 122	31316
C 1656	33PF 2	100	5322 122	31556
C 1657	10NF-20+80	40	4822 122	30043
C 1658	10NF-20+80	40	4822 122	30043
C 1659	22NF-20+80	40	4822 122	30103
C 1660	22NF-20+80	40	4822 122	30103
C 1661	22NF-20+80	40	4822 122	30103

RESISTORS

POSNR	DESCRIPTION	ORDERING	CODE
R 1	10K 20	0.1W 5322 101	24117
R 2	1K 20	0.1W 5322 101	24118
R 3	1K 20	0.1W 5322 101	64018
R 4	47K +47K LIN	0.1W 5322 103	50002
R 5	100K 20	0.1W 5322 101	44044
R 6	5K 10T LIN	5322 102	40061
R 7	100K 20	0.1W 5322 101	44044
R 8	2,2M 20	0.1W 5322 101	24098
R 9	1K 20	0.1W 5322 101	44024
R 10	1K 20	0.1W 5322 101	44024
R 11	10K 20	0.1W 5322 101	44023
R 12	10K 20	0.1W 5322 101	44023
R 13	100K 20	0.1W 5322 101	24178
R 14	4,7K 20	0.1W 5322 101	24119
R 15	22K 20	0.1W 5322 101	44025
R 16	47K 20	0.1W 5322 101	20605
R 200	10K 1	MR25 4822 116	51253
R 201	23,7K 1	MR25 5322 116	54646
R 202	1,21K 1	MR25 5322 116	54557
R 203	1K 1	MR25 5322 116	54549
R 204	220 20	0.5W 5322 101	14051
R 206	2,87K 1	MR25 5322 116	50414
R 207	2,74K 1	MR25 5322 116	50636
R 208	30,1 1	MR25 5322 116	50904
R 209	30,1 1	MR25 5322 116	50904
R 210	1M 1	MR30 5322 116	54188
R 212	10K 1	MR25 4822 116	51253
R 227	249 1	MR25 5322 116	54499
R 251	4,99 1	MR25 5322 116	50568
R 252	4,99 1	MR25 5322 116	50568
R 253	4,99 1	MR25 5322 116	50568
R 254	4,99 1	MR25 5322 116	50568
R 256	4,99 1	MR25 5322 116	50568
R 258	4,99 1	MR25 5322 116	50568
R 259	4,99 1	MR25 5322 116	50568
R 261	1 5	CR25 4822 110	73027
R 262	4,99 1	MR25 5322 116	50568
R 263	4,99 1	MR25 5322 116	50568
R 264	4,99 1	MR25 5322 116	50568
R 266	4,99 1	MR25 5322 116	50568
R 267	4,99 1	MR25 5322 116	50568
R 268	1 5	CR25 4822 110	73027
R 269	4,99 1	MR25 5322 116	50568
R 271	4,99 1	MR25 5322 116	50568
R 272	4,99 1	MR25 5322 116	50568
R 274	4,99 1	MR25 5322 116	50568
R 276	1 5	CR25 4822 110	73027
R 277	1 5	CR25 4822 110	73027
R 278	4,99 1	MR25 5322 116	50568
R 279	100 1	MR25 5322 116	54469
R 281	100 1	MR25 5322 116	54469
R 302	1M 1	MR30 5322 116	54188
R 303	100 1	MR25 5322 116	54469
R 304	75 1	MR25 5322 116	54459
R 306	75 1	MR25 5322 116	54459
R 307	191K 1	MR30 5322 116	55319
R 308	681K 1	MR30 5322 116	54263
R 309	845K 1	MR30 5322 116	55379
R 311	549K 1	MR30 5322 116	55139
R 312	205K 1	MR25 5322 116	54727
R 313	732K 1	MR30 5322 116	55321
R 314	806K 1	MR30 5322 116	55078

POSNR	DESCRIPTION			ORDERING CODE		
R 316	8,2M	10	CR25	4822	110	72212
R 317	1M	1	MR30	5322	116	54188
R 318	90,9K	0,25	MR24C	5322	116	50859
R 319	8,25K	0,25	MR24C	5322	116	50979
R 350	10	1	MR25	5322	116	50452
R 351	22K	20	0.5W	5322	101	14069
R 352	20,5K	1	MR25	5322	116	54643
R 353	22K	20	0.5W	5322	101	14069
R 354	20,5K	1	MR25	5322	116	54643
R 355	4,64K	1	MR25	5322	116	50484
R 356	22K	20	0.5W	5322	101	14069
R 357	20,5K	1	MR25	5322	116	54643
R 358	487K	1	MR30	5322	116	55243
R 359	6,81K	1	MR25	5322	116	54012
R 360	7,5K	1	MR25	5322	116	54608
R 361	6,49K	1	MR25	5322	116	54603
R 362	1,62K	1	MR25	5322	116	55359
R 363	2,05K	1	MR25	5322	116	50664
R 364	1,62K	1	MR25	5322	116	55359
R 365	681	1	MR25	4822	116	51233
R 366	10	1	MR25	5322	116	50452
R 367	154K	1	MR25	5322	116	54714
R 368	511K	1	MR30	5322	116	54123
R 369	5,11	1	MR25	5322	116	54192
R 370	10	1	MR25	5322	116	50452
R 371	1M	1	MR30	5322	116	54188
R 372	1K	1	MR25	5322	116	54549
R 373	953K	1	MR30	5322	116	55257
R 374	3,65K	1	MR25	5322	116	54587
R 376	133K	1	MR25	5322	116	54708
R 377	121	1	MR25	5322	116	54426
R 402	1M	1	MR30	5322	116	54188
R 403	100	1	MR25	5322	116	54469
R 404	75	1	MR25	5322	116	54459
R 406	75	1	MR25	5322	116	54459
R 407	191K	1	MR30	5322	116	55319
R 408	681K	1	MR30	5322	116	54263
R 409	845K	1	MR30	5322	116	55379
R 411	549K	1	MR30	5322	116	55139
R 412	205K	1	MR25	5322	116	54727
R 413	732K	1	MR30	5322	116	55321
R 414	806K	1	MR30	5322	116	55078
R 416	8,2M	10	CR25	4822	110	72212
R 417	1M	1	MR30	5322	116	54188
R 418	90,9K	0,25	MR24C	5322	116	50859
R 419	8,25K	0,25	MR24C	5322	116	50979
R 451	3,83K	1	MR25	5322	116	54589
R 452	20,5K	1	MR25	5322	116	54643
R 453	22K	20	0.5W	5322	101	14069
R 454	20,5K	1	MR25	5322	116	54643
R 455	10	1	MR25	5322	116	50452
R 456	22K	20	0.5W	5322	101	14069
R 457	20,5K	1	MR25	5322	116	54643
R 458	22K	20	0.5W	5322	101	14069
R 459	4,99	1	MR25	5322	116	50568
R 460	10	1	MR25	5322	116	50452
R 461	487K	1	MR30	5322	116	55243
R 462	2,49K	1	MR25	5322	116	50581
R 463	1K	1	MR25	5322	116	54549
R 464	1,69K	1	MR25	5322	116	54567
R 466	825	1	MR25	5322	116	54541
R 467	1,69K	1	MR25	5322	116	54567

POSNR	DESCRIPTION		ORDERING	CODE
R 468	3,01K	1	MR25 4822 116	51246
R 469	10	1	MR25 5322 116	50452
R 500	51,1	1	MR25 5322 116	54442
R 501	51,1	1	MR25 5322 116	54442
R 502	806K	1	MR30 5322 116	55078
R 503	12,7K	1	MR25 5322 116	50443
R 504	470	20	0,5W 5322 101	14047
R 506	12,7K	1	MR25 5322 116	50443
R 507	6,19K	1	MR25 5322 116	50608
R 508	6,49K	1	MR25 5322 116	54603
R 509	619	1	MR25 5322 116	54529
R 511	511	0,5	MR25 4822 116	51282
R 512	511	0,5	MR25 4822 116	51282
R 513	105	1	MR25 5322 116	54472
R 514	22K	20	0,5W 5322 101	14069
R 516	51,1K	1	MR25 5322 116	50672
R 517	5,9K	1	MR25 5322 116	50583
R 518	100	1	MR25 5322 116	54469
R 519	162	1	MR25 5322 116	50417
R 521	1K	20	0,5W 5322 100	10112
R 522	44,2	1	MR25 5322 116	50818
R 523	44,2	1	MR25 5322 116	50818
R 524	100	0,5	MR25 5322 116	55549
R 526	100	0,5	MR25 5322 116	55549
R 527	5,62K	0,5	MR25 4822 116	51281
R 527	10K	1	MR25 4822 116	51253
R 528	909	0,5	MR25 5322 116	55278
R 529	51,1	1	MR25 5322 116	54442
R 531	51,1	1	MR25 5322 116	54442
R 532	909	0,5	MR25 5322 116	55278
R 533	5,62K	0,5	MR25 4822 116	51281
R 534	825	1	MR25 5322 116	54541
R 535	825	1	MR25 5322 116	54541
R 536	30,1	1	MR25 5322 116	50904
R 537	866	1	MR25 5322 116	54543
R 538	1,5K	5	0,5W 5322 116	34054
R 539	30,1	1	MR25 5322 116	50904
R 540	402	1	MR25 5322 116	54519
R 541	348	1	MR25 5322 116	54515
R 542	249	1	MR25 5322 116	54499
R 543	100	20	0,5W 5322 101	14011
R 546	953	1	MR25 5322 116	54547
R 547	220	20	0,05W 4822 100	10019
R 548	953	1	MR25 5322 116	54547
R 549	100	1	MR25 5322 116	54469
R 550	10	1	MR25 5322 116	50452
R 551	100	1	MR25 5322 116	54469
R 552	121	1	MR25 5322 116	54426
R 553	121	1	MR25 5322 116	54426
R 554	909	1	MR25 5322 116	55278
R 558	17,8K	1	MR25 5322 116	54637
R 559	5,11K	1	MR25 5322 116	54595
R 568	17,8K	1	MR25 5322 116	54637
R 569	5,9K	1	MR25 5322 116	50583
R 571	178	1	MR25 5322 116	54492
R 572	178	1	MR25 5322 116	54492
R 573	2,26K	1	MR25 5322 116	50675
R 577	100	1	MR25 5322 116	54469
R 600	51,1	1	MR25 5322 116	54442
R 601	51,1	1	MR25 5322 116	54442
R 602	806K	1	MR30 5322 116	55078
R 603	12,7K	1	MR25 5322 116	50443
R 604	470	20	0,5W 5322 101	14047
R 606	12,7K	1	MR25 5322 116	50443

POSNR	DESCRIPTION		ORDERING CODE			
R 607	6,19K	1	MR25	5322	116	50608
R 608	6,49K	1	MR25	5322	116	54603
R 609	619	1	MR25	5322	116	54529
R 611	511	0,5	MR25	4822	116	51282
R 612	511	0,5	MR25	4822	116	51282
R 613	105	1	MR25	5322	116	54472
R 614	22K	20	0.5W	5322	101	14069
R 616	51,1K	1	MR25	5322	116	50672
R 617	5,9K	1	MR25	5322	116	50583
R 618	100	1	MR25	5322	116	54469
R 619	162	1	MR25	5322	116	50417
R 621	1K	20	0,5W	5322	100	10112
R 622	44,2	1	MR25	5322	116	50818
R 623	44,2	1	MR25	5322	116	50818
R 624	100	0,5	MR25	5322	116	55549
R 626	100	0,5	MR25	5322	116	55549
R 627	5,62K	0,5	MR25	4822	116	51281
R 628	909	0,5	MR25	5322	116	55278
R 629	51,1	1	MR25	5322	116	54442
R 631	51,1	1	MR25	5322	116	54442
R 632	909	0,5	MR25	5322	116	55278
R 633	5,62K	0,5	MR25	4822	116	51281
R 634	825	1	MR25	5322	116	54541
R 635	825	1	MR25	5322	116	54541
R 636	30,1	1	MR25	5322	116	50904
R 637	866	1	MR25	5322	116	54543
R 638	1,5K	5	0.5W	5322	116	34054
R 639	30,1	1	MR25	5322	116	50904
R 640	402	1	MR25	5322	116	54519
R 641	158	0,5	MR25	5322	116	55418
R 646	1K	1	MR25	5322	116	54549
R 647	100	20	0,5W	5322	101	14011
R 648	1K	1	MR25	5322	116	54549
R 649	100	1	MR25	5322	116	54469
R 650	10	1	MR25	5322	116	50452
R 651	100	1	MR25	5322	116	54469
R 652	121	1	MR25	5322	116	54426
R 653	121	1	MR25	5322	116	54426
R 654	909	1	MR25	5322	116	55278
R 658	17,8K	1	MR25	5322	116	54637
R 659	5,11K	1	MR25	5322	116	54595
R 661	31,5K	1	MR25	5322	116	54657
R 662	17,8K	1	MR25	5322	116	54637
R 663	14K	1	MR25	5322	116	54629
R 664	8,25K	1	MR25	5322	116	54558
R 668	17,8K	1	MR25	5322	116	54637
R 669	5,9K	1	MR25	5322	116	50583
R 671	178	1	MR25	5322	116	54492
R 672	178	1	MR25	5322	116	54492
R 673	2,26K	1	MR25	5322	116	50675
R 674	47K	20	0,5W	5322	101	14048
R 676	33,2K	1	MR25	4822	116	51259
R 677	100	1	MR25	5322	116	54469
R 701	100	1	MR25	5322	116	54469
R 702	1,27K	1	MR25	5322	116	50555
R 703	750	1	MR25	4822	116	51234
R 704	383	1	MR25	5322	116	54518
R 706	1,27K	1	MR25	5322	116	50555
R 707	22,6K	1	MR25	5322	116	50481
R 708	6,81K	1	MR25	5322	116	54012
R 709	2,49K	1	MR25	5322	116	50581
R 711	2,49K	1	MR25	5322	116	50581
R 712	4,02K	1	MR25	5322	116	55448
R 713	4,02K	1	MR25	5322	116	55448
R 714	4,02K	1	MR25	5322	116	55448

POSNR	DESCRIPTION		ORDERING	CODE
R 716	4,02K	1	MR25 5322 116	55448
R 717	100	1	MR25 5322 116	54469
R 801	4,02K	1	MR25 5322 116	55448
R 802	8,25K	1	MR25 5322 116	54558
R 803	100	1	MR25 5322 116	54469
R 804	100	1	MR25 5322 116	54469
R 806	121	1	MR25 5322 116	54426
R 807	121	1	MR25 5322 116	54426
R 809	1,33K	1	MR25 5322 116	54561
R 811	7,87K	1	MR25 5322 116	50458
R 812	4,7K	20	0.5W 5322 100	10114
R 813	10K	20	0.5W 5322 100	10113
R 814	2,2K	20	0.5W 5322 101	14008
R 816	30,1	1	MR25 5322 116	50904
R 817	100	20	0.05W 4822 100	10075
R 818	30,1	1	MR25 5322 116	50904
R 819	28,7	1	MR25 5322 116	54068
R 821	28,7	1	MR25 5322 116	54068
R 823	169	1	MR25 5322 116	54489
R 824	7,87K	1	MR25 5322 116	50458
R 825	4,99	1	MR25 5322 116	50568
R 826	2,26K	1	MR25 5322 116	50675
R 828	100	1	MR25 5322 116	54469
R 829	100	1	MR25 5322 116	54469
R 831	90,9	1	MR25 5322 116	54466
R 832	90,9	1	MR25 5322 116	54466
R 833	909	1	MR25 5322 116	55278
R 837	909	1	MR25 5322 116	55278
R 838	909	1	MR25 5322 116	55278
R 839	909	1	MR25 5322 116	55278
R 843	464	1	MR25 5322 116	50536
R 847	90,9	1	MR25 5322 116	54466
R 848	100	20	0,5W 5322 101	14011
R 849	90,9	1	MR25 5322 116	54466
R 851	90,9	1	MR25 5322 116	54466
R 852	51,1	1	MR25 5322 116	54442
R 853	51,1	1	MR25 5322 116	54442
R 854	90,9	1	MR25 5322 116	54466
R 856	127	1	MR25 5322 116	54479
R 857	3,48K	1	MR25 5322 116	54585
R 858	3,01K	1	MR25 4822 116	51246
R 859	1,62K	1	MR25 5322 116	55359
R 861	1,62K	1	MR25 5322 116	55359
R 862	1,62K	1	MR25 5322 116	55359
R 863	1,62K	1	MR25 5322 116	55359
R 864	1K	1	MR25 5322 116	54549
R 866	1K	1	MR25 5322 116	54549
R 1001	51,1	1	MR25 5322 116	54442
R 1002	147K	1	MR25 5322 116	54712
R 1003	51,1K	1	MR25 5322 116	50672
R 1004	51,1K	1	MR25 5322 116	50672
R 1006	140K	1	MR25 5322 116	54259
R 1007	511K	1	MR25 5322 116	55258
R 1008	3,83K	1	MR25 5322 116	54589
R 1009	8,25K	1	MR25 5322 116	54558
R 1011	4,02K	1	MR25 5322 116	55448
R 1012	226K	1	MR25 5322 116	54729
R 1013	100K	1	MR25 4822 116	51268
R 1014	12,7K	1	MR25 5322 116	50443
R 1016	470	20	0.05W 4822 100	10038
R 1017	12,7K	1	MR25 5322 116	50443
R 1018	2,87K	1	MR25 5322 116	50414
R 1019	562	1	MR25 5322 116	54009
R 1021	562	1	MR25 5322 116	54009
R 1022	3,65K	1	MR25 5322 116	54587

POSNR	DESCRIPTION		ORDERING	CODE
R 1023	1,54K	1	MR25	5322 116 50586
R 1024	1,54K	1	MR25	5322 116 50586
R 1026	249	1	MR25	5322 116 54499
R 1027	249	1	MR25	5322 116 54499
R 1028	6,19K	1	MR25	5322 116 50608
R 1029	4,02K	1	MR25	5322 116 55448
R 1031	3,32K	1	MR25	5322 116 54005
R 1032	8,25K	1	MR25	5322 116 54558
R 1034	20,5K	1	MR25	5322 116 54643
R 1036	100K	1	MR25	4822 116 51268
R 1037	2,49K	1	MR25	5322 116 50581
R 1038	3,65K	1	MR25	5322 116 54587
R 1039	17,8K	1	MR25	5322 116 54637
R 1041	12,1K	1	MR25	5322 116 50572
R 1042	1M	1	MR30	5322 116 54188
R 1043	10K	1	MR25	4822 116 51253
R 1044	3,01K	1	MR25	4822 116 51246
R 1046	1,4K	1	MR25	5322 116 54562
R 1047	1,78K	1	MR25	5322 116 50515
R 1048	5,9K	1	MR25	5322 116 50583
R 1049	1M	1	MR30	5322 116 54188
R 1051	196K	1	MR25	5322 116 55364
R 1052	4,02K	1	MR25	5322 116 55448
R 1101	51,1	1	MR25	5322 116 54442
R 1102	17,8K	1	MR25	5322 116 54637
R 1103	511K	1	MR25	5322 116 55258
R 1104	1,78K	1	MR25	5322 116 50515
R 1106	12,7K	1	MR25	5322 116 50443
R 1107	470	20	0.05W	4822 100 10038
R 1108	12,7K	1	MR25	5322 116 50443
R 1109	562	1	MR25	5322 116 54009
R 1111	562	1	MR25	5322 116 54009
R 1112	4,02K	1	MR25	5322 116 55448
R 1113	3,65K	1	MR25	5322 116 54587
R 1114	8,25K	1	MR25	5322 116 54558
R 1116	100K	1	MR25	4822 116 51268
R 1117	3,32K	1	MR25	5322 116 54005
R 1118	8,25K	1	MR25	5322 116 54558
R 1119	4,02K	1	MR25	5322 116 55448
R 1121	1,54K	1	MR25	5322 116 50586
R 1122	2,49K	1	MR25	5322 116 50581
R 1123	1,4K	1	MR25	5322 116 54562
R 1124	1,78K	1	MR25	5322 116 50515
R 1201	5,11K	1	MR25	5322 116 54595
R 1202	5,11K	1	MR25	5322 116 54595
R 1203	5,11K	1	MR25	5322 116 54595
R 1204	44,2	1	MR25	5322 116 50818
R 1205	9,09	1	MR25	5322 116 50863
R 1206	1,27K	1	MR25	5322 116 50555
R 1207	402	1	MR25	5322 116 54519
R 1208	10K	1	MR25	4822 116 51253
R 1209	10K	1	MR25	4822 116 51253
R 1210	30,1	1	MR25	5322 116 50904
R 1211	32,4	0,5	MR25	5322 116 55421
R 1212	1,4K	1	MR25	5322 116 54562
R 1213	9,53K	1	MR25	5322 116 54617
R 1214	37,4K	1	MR25	5322 116 54663
R 1215	26,1K	1	MR25	5322 116 54651
R 1216	22K	20	0.5W	5322 101 14069
R 1217	1,54K	1	MR25	5322 116 50586
R 1218	23,7K	1	MR25	5322 116 54646
R 1219	44,2	1	MR25	5322 116 50818
R 1221	7,87K	1	MR25	5322 116 50458
R 1222	33,2K	1	MR25	4822 116 51259
R 1223	316	1	MR25	5322 116 54511

POSNR	DESCRIPTION		ORDERING	CODE		
R 1224	2,05K	1	MR25	5322	116	50664
R 1226	21,5K	1	MR25	5322	116	50451
R 1227	15,4K	1	MR25	5322	116	50479
R 1276	261K	0,5	MR25	5322	116	54736
R 1277	412K	0,5	MR25	5322	116	55424
R 1278	205K	0,5	MR25	5322	116	55387
R 1279	41,2K	0,5	MR25	5322	116	55423
R 1281	8,06K	0,5	MR25	5322	116	55428
R 1282	2K	0,5	MR25	4822	116	51243
R 1283	365	0,5	MR25	5322	116	55422
R 1284	412K	0,5	MR25	5322	116	55424
R 1286	82,5K	0,5	MR25	5322	116	55374
R 1287	20,5K	0,5	MR25	5322	116	55419
R 1288	4,02K	0,1	MR24E	5322	116	54283
R 1289	768	0,5	MR25	5322	116	55427
R 1290	6,19K	1	MR25	5322	116	50608
R 1291	909	1	MR25	5322	116	55278
R 1292	953K	0,5	MR30	5322	116	55382
R 1301	4,99	1	MR25	5322	116	50568
R 1302	2,74K	1	MR25	5322	116	50636
R 1303	5,11K	1	MR25	5322	116	54595
R 1304	909	1	MR25	5322	116	55278
R 1305	5,11K	1	MR25	5322	116	54595
R 1306	5,11K	1	MR25	5322	116	54595
R 1307	2,26K	1	MR25	5322	116	50675
R 1308	100	1	MR25	5322	116	54469
R 1309	5,11K	1	MR25	5322	116	54595
R 1311	2,74K	1	MR25	5322	116	50636
R 1312	33,2K	1	MR25	4822	116	51259
R 1313	365	1	MR25	5322	116	54516
R 1314	154	1	MR25	5322	116	50506
R 1316	2,49K	1	MR25	5322	116	50581
R 1317	2,87K	1	MR25	5322	116	50414
R 1318	22K	20	0.05W	4822	100	10051
R 1319	22K	20	0.05W	4822	100	10051
R 1321	5,11K	1	MR25	5322	116	54595
R 1322	10K	1	MR25	4822	116	51253
R 1324	402	1	MR25	5322	116	54519
R 1326	10K	1	MR25	4822	116	51253
R 1327	383	1	MR25	5322	116	54518
R 1328	10	1	MR25	5322	116	50452
R 1329	4,87K	1	MR25	5322	116	50509
R 1330	20,5	1	MR25	5322	116	50678
R 1331	18,7K	1	MR25	5322	116	50558
R 1332	30,1K	1	MR25	5322	116	54655
R 1333	44,2	1	MR25	5322	116	50818
R 1334	2,26K	1	MR25	5322	116	50675
R 1336	22K	20	0.5W	5322	101	14069
R 1337	78,7K	1	MR25	5322	116	50533
R 1338	61,9K	1	MR25	5322	116	50872
R 1339	33,2K	1	MR25	4822	116	51259
R 1340	48,7K	1	MR25	5322	116	50442
R 1341	51,1K	1	MR25	5322	116	50672
R 1342	316	1	MR25	5322	116	54511
R 1343	2,05K	1	MR25	5322	116	50664
R 1344	22K	20	0.05W	4822	100	10051
R 1346	3,83K	1	MR25	5322	116	54589
R 1347	44,2	1	MR25	5322	116	50818
R 1376	44,2K	0,5	MR25	5322	116	55449
R 1377	8,45K	0,1	MR24E	5322	116	55222
R 1378	1,37K	0,5	MR25	5322	116	55446
R 1379	17,4K	0,5	MR25	5322	116	55447
R 1381	4,02K	0,5	MR25	5322	116	55448
R 1382	487	0,5	MR25	5322	116	55451
R 1383	909	1	MR25	5322	116	55278

POSNR	DESCRIPTION		ORDERING CODE
R 1384	88,7K	0,5	MR25 5322 116 55452
R 1385	6,19K	1	MR25 5322 116 50608
R 1401	3,16K	1	MR25 5322 116 50579
R 1402	4,02K	1	MR25 5322 116 55448
R 1403	3,16K	1	MR25 5322 116 50579
R 1404	20,5K	1	MR25 5322 116 54643
R 1406	5,11K	1	MR25 5322 116 54595
R 1407	5,11K	1	MR25 5322 116 54595
R 1408	5,11K	1	MR25 5322 116 54595
R 1409	715	1	MR25 5322 116 50571
R 1411	2,74K	1	MR25 5322 116 50636
R 1412	8,25K	1	MR25 5322 116 54558
R 1413	8,66K	1	MR25 5322 116 54613
R 1414	8,25K	1	MR25 5322 116 54558
R 1416	3,32K	1	MR25 5322 116 54005
R 1417	1K	20	0,5W 5322 100 10112
R 1418	287	1	MR25 5322 116 54506
R 1419	100	20	0,5W 5322 101 14011
R 1421	2,26K	1	MR25 5322 116 50675
R 1422	3,01K	1	MR25 4822 116 51246
R 1423	16,2K	1	MR25 5322 116 55361
R 1424	20,5K	1	MR25 5322 116 54643
R 1425	100	1	MR25 5322 116 54469
R 1426	36,5K	1	MR25 5322 116 50726
R 1427	12,1K	1	MR25 5322 116 50572
R 1428	154K	1	MR25 5322 116 54714
R 1429	33,2K	1	MR25 4822 116 51259
R 1431	33,2K	1	MR25 4822 116 51259
R 1432	1K	1	MR25 5322 116 54549
R 1433	33,2K	1	MR25 4822 116 51259
R 1434	33,2K	1	MR25 4822 116 51259
R 1436	154K	1	MR25 5322 116 54714
R 1437	30,1	1	MR25 5322 116 50904
R 1438	3,01K	1	MR25 4822 116 51246
R 1439	30,1	1	MR25 5322 116 50904
R 1441	1,15K	1	MR25 5322 116 50415
R 1442	1,15K	1	MR25 5322 116 50415
R 1443	10K	1	MR25 4822 116 51253
R 1444	4,64K	1	MR25 5322 116 50484
R 1446	365K	1	MR30 5322 116 54762
R 1447	365K	1	MR30 5322 116 54762
R 1448	64,9K	1	MR25 5322 116 50514
R 1449	5,11K	1	MR25 5322 116 54595
R 1451	5,11K	1	MR25 5322 116 54595
R 1501	511	1	MR25 4822 116 51282
R 1502	226K	1	MR25 5322 116 54729
R 1503	10K	1	MR25 4822 116 51253
R 1504	10K	1	MR25 4822 116 51253
R 1506	10K	1	MR25 4822 116 51253
R 1507	22K	20	0.05W 4822 100 10051
R 1508	22,6K	1	MR25 5322 116 50481
R 1509	22,6K	1	MR25 5322 116 50481
R 1511	11,5K	1	MR25 5322 116 55358
R 1512	51,1K	1	MR25 5322 116 50672
R 1513	6,19K	1	MR25 5322 116 50608
R 1514	26,1K	1	MR25 5322 116 54651
R 1516	6,19K	1	MR25 5322 116 50608
R 1517	23,7K	1	MR25 5322 116 54646
R 1518	2,05K	1	MR25 5322 116 50664
R 1519	511	1	MR25 4822 116 51282
R 1521	487	1	MR25 5322 116 55451
R 1522	464K	1	MR30 5322 116 54759
R 1524	4,02K	1	MR25 5322 116 55448
R 1526	100	1	MR25 5322 116 54469
R 1527	64,9K	1	MR30 4822 116 51175

POSNR	DESCRIPTION		ORDERING	CODE		
R 1528	511	1	MR25	4822	116	51282
R 1529	24,9K	1	MR25	5322	116	54648
R 1531	26,1K	1	MR25	5322	116	54651
R 1532	5,9K	1	MR25	5322	116	50583
R 1533	12,1K	1	MR25	5322	116	50572
R 1534	1M	1	MR30	5322	116	54188
R 1535	1K	1	MR30	5322	116	54207
R 1536	100	1	MR25	5322	116	54469
R 1537	10K	20	0,5W	5322	100	10113
R 1538	1,2M	5	VR37	4822	110	42189
R 1539	2,2M	5	VR37	4822	110	42196
R 1541	5,6M	5	VR37	4822	110	42207
R 1542	78,7K	1	MR25	5322	116	50533
R 1543	100K	20	0.05W	4822	100	10072
R 1544	121K	1	MR25	5322	116	54704
R 1546	16,2K	1	MR25	5322	116	55361
R 1547	26,1K	1	MR25	5322	116	54651
R 1548	196K	1	MR25	5322	116	55364
R 1549	1M	20	0.05W	4822	100	10103
R 1551	383K	1	MR30	5322	116	54761
R 1552	4,64K	1	MR25	5322	116	50484
R 1553	1M	1	MR30	5322	116	54188
R 1601	301	1	MR25	5322	116	54508
R 1602	12,1K	1	MR25	5322	116	50572
R 1603	2,05K	1	MR25	5322	116	50664
R 1604	10K	1	MR25	4822	116	51253
R 1606	681	1	MR25	4822	116	51233
R 1607	22K	20	0.05W	4822	100	10051
R 1608	36,5K	1	MR25	5322	116	50726
R 1609	909	1	MR25	5322	116	55278
R 1611	10K	1	MR25	4822	116	51253
R 1612	681	1	MR25	4822	116	51233
R 1613	6,19K	1	MR25	5322	116	50608
R 1614	3,16K	1	MR25	5322	116	50579
R 1616	2,05K	1	MR25	5322	116	50664
R 1617	301	1	MR25	5322	116	54508
R 1618	26,1K	1	MR25	5322	116	54651
R 1619	12,1K	1	MR25	5322	116	50572
R 1651	4,02K	1	MR25	5322	116	55448
R 1652	26,1K	1	MR25	5322	116	54651
R 1653	36,5K	1	MR25	5322	116	50726
R 1654	100K	1	MR25	4822	116	51268
R 1656	100K	1	MR25	4822	116	51268
R 1657	17,8K	1	MR25	5322	116	54637
R 1658	3,48K	1	MR25	5322	116	54585
R 1659	7,87K	1	MR25	5322	116	50458
R 1661	7,87K	1	MR25	5322	116	50458
R 1662	26,1K	1	MR25	5322	116	54651
R 1663	7,5K	1	MR25	5322	116	54608
R 1664	8,25K	1	MR25	5322	116	54558
R 1666	4,22K	1	MR25	5322	116	50729
R 1667	4,02K	1	MR25	5322	116	55448
R 1668	8,25K	1	MR25	5322	116	54558
R 1669	7,5K	1	MR25	5322	116	54608
R 1671	30,1K	1	MR25	5322	116	54655
R 1672	7,5K	1	MR25	5322	116	54608
R 1673	562	1	MR25	5322	116	54009
R 1674	562	1	MR25	5322	116	54009
R 1676	14,7K	1	MR25	5322	116	54632
R 1677	24,9K	1	MR25	5322	116	54648

POSNR	DESCRIPTION		ORDERING	CODE
R 1678	24,9K	1	MR25	5322 116 54648
R 1679	14,7K	1	MR25	5322 116 54632
R 1681	10K	1	MR25	4822 116 51253
R 1682	10K	1	MR25	4822 116 51253
R 1683	511	1	MR25	4822 116 51282
R 1684	511	1	MR25	4822 116 51282
R 1686	8,25K	1	MR25	5322 116 54558
R 1687	6,81K	1	MR25	5322 116 54012
R 1688	681	1	MR25	4822 116 51233
R 468	3,01K	1	MR25	4822 116 51246

SEMI CONDUCTORS

POSNR	DESCRIPTION	ORDERING	CODE
V 1	D14-125GH/08	5322 131	24029
V 201	BY225-200	4822 130	50312
V 206	BYX49-300	5322 130	34304
V 207	BD237	4822 130	44235
V 208	BAW62	4822 130	30613
V 209	BZX79-C5V6	4822 130	34173
V 211	BZX75-C3V6	4822 130	30765
V 212	BZX75-C3V6	4822 130	30765
V 213	BAW62	4822 130	30613
V 214	BC548C	4822 130	44196
V 216	BC558B	4822 130	44197
V 217	BD237	4822 130	44235
V 218	BD237	4822 130	44235
V 219	BAW62	4822 130	30613
V 221	BAW62	4822 130	30613
V 222	BAW62	4822 130	30613
V 223	BAW62	4822 130	30613
V 224	BAW62	4822 130	30613
V 232	BY 509	4822 130	41485
V 233	BZX61-C110	5322 130	34671
V 234	BY206	4822 130	30839
V 236	BY206	4822 130	30839
V 237	BAW62	4822 130	30613
V 238	BAX12	5322 130	34605
V 239	BAX12	5322 130	34605
V 241	BAX12	5322 130	34605
V 242	BAX12	5322 130	34605
V 243	BAX12	5322 130	34605
V 244	BAX12	5322 130	34605
V 246	BAW62	4822 130	30613
V 247	BY206	4822 130	30839
V 351	BF450	4822 130	44237
V 352	BF450	4822 130	44237
V 353	BC548C	4822 130	44196
V 354	BZX79-C4V7	4822 130	34174
V 356	BAW62	4822 130	30613
V 357	BAW62	4822 130	30613
V 451	BF450	4822 130	44237
V 452	BF199	4822 130	44154
V 453	BC548C	4822 130	44196
V 454	BAW62	4822 130	30613
V 456	BAW62	4822 130	30613
V 501	BAV45	5322 130	34037
V 504	BFS21A	5322 130	40709
V 508	BF450	4822 130	44237
V 509	BF450	4822 130	44237
V 511	BF450	4822 130	44237
V 512	BF450	4822 130	44237
V 513	BC558B	4822 130	44197
V 514	BC558B	4822 130	44197
V 518	BC548C	4822 130	44196
V 519	BC548C	4822 130	44196
V 521	BAW62	4822 130	30613
V 522	BAW62	4822 130	30613
V 523	BAW62	4822 130	30613
V 524	BF324	4822 130	41448
V 526	BF324	4822 130	41448
V 601	BAV45	5322 130	34037
V 604	BFS21A	5322 130	40709
V 608	BF450	4822 130	44237
V 609	BF450	4822 130	44237
V 611	BF450	4822 130	44237

POSNR	DESCRIPTION	ORDERING CODE
V 612	BF450	4822 130 44237
V 613	BC558B	4822 130 44197
V 614	BC558B	4822 130 44197
V 616	BC558B	4822 130 44197
V 617	BC558B	4822 130 44197
V 618	BC548C	4822 130 44196
V 619	BC548C	4822 130 44196
V 621	BAW62	4822 130 30613
V 622	BAW62	4822 130 30613
V 623	BAW62	4822 130 30613
V 624	BF324	4822 130 41448
V 626	BF324	4822 130 41448
V 701	BAW62	4822 130 30613
V 702	BAW62	4822 130 30613
V 703	BC548C	4822 130 44196
V 704	BC548C	4822 130 44196
V 801	BC558B	4822 130 44197
V 802	BC548C	4822 130 44196
V 803	BC548C	4822 130 44196
V 804	BF199	4822 130 44154
V 806	BF199	4822 130 44154
V 807	BF199	4822 130 44154
V 808	BF199	4822 130 44154
V 809	BC548C	4822 130 44196
V 1001	OA95	4822 130 30191
V 1002	OA95	4822 130 30191
V 1003	BAW62	4822 130 30613
V 1004	BAV45	5322 130 34037
V 1006	ON561	5322 130 40709
V 1007	BF450	4822 130 44237
V 1008	BC548C	4822 130 44196
V 1009	BC548C	4822 130 44196
V 1011	BC548C	4822 130 44196
V 1012	BAW62	4822 130 30613
V 1013	BAW62	4822 130 30613
V 1014	BAW62	4822 130 30613
V 1016	BAW62	4822 130 30613
V 1017	BAW62	4822 130 30613
V 1018	BAW62	4822 130 30613
V 1019	BAW62	4822 130 30613
V 1020	BAW62	4822 130 30613
V 1021	BAW62	4822 130 30613
V 1022	BC548C	4822 130 44196
V 1023	BC548C	4822 130 44196
V 1024	BC548C	4822 130 44196
V 1026	BF450	4822 130 44237
V 1027	BAW62	4822 130 30613
V 1028	BC558B	4822 130 44197
V 1101	BAV45	5322 130 34037
V 1102	ON561	5322 130 40709
V 1103	BC548C	4822 130 44196
V 1104	BAW62	4822 130 30613
V 1106	BAW62	4822 130 30613
V 1107	BAW62	4822 130 30613
V 1108	BAW62	4822 130 30613
V 1109	BF450	4822 130 44237
V 1201	OA95	4822 130 30191
V 1202	BAW62	4822 130 30613
V 1203	BAW62	4822 130 30613
V 1206	BAW62	4822 130 30613
V 1207	BSX20	5322 130 40417
V 1208	BSX20	5322 130 40417
V 1209	BC558B	4822 130 44197
V 1211	BAW62	4822 130 30613
V 1212	BC548C	4822 130 44196

POSNR	DESCRIPTION	ORDERING CODE
V 1213	BC548C	4822 130 44196
V 1214	BC548C	4822 130 44196
V 1216	BAW62	4822 130 30613
V 1217	BAW62	4822 130 30613
V 1218	BC548C	4822 130 44196
V 1219	BC548C	4822 130 44196
V 1221	BC548C	4822 130 44196
V 1301	BC558B	4822 130 44197
V 1302	BC548C	4822 130 44196
V 1303	BC548C	4822 130 44196
V 1304	BC548C	4822 130 44196
V 1305	BAW62	4822 130 30613
V 1306	BC548C	4822 130 44196
V 1307	BC548C	4822 130 44196
V 1308	BAW62	4822 130 30613
V 1314	BSX20	5322 130 40417
V 1316	BC558B	4822 130 44197
V 1318	BC548C	4822 130 44196
V 1319	BC548C	4822 130 44196
V 1321	BC548C	4822 130 44196
V 1322	BC548C	4822 130 44196
V 1323	BAW62	4822 130 30613
V 1324	BC548C	4822 130 44196
V 1326	BAW62	4822 130 30613
V 1401	BAW62	4822 130 30613
V 1402	BAW62	4822 130 30613
V 1403	BAW62	4822 130 30613
V 1404	BAW62	4822 130 30613
V 1406	BC548C	4822 130 44196
V 1407	BC548C	4822 130 44196
V 1408	BAW62	4822 130 30613
V 1409	BC558B	4822 130 44197
V 1411	BAW62	4822 130 30613
V 1412	BAW62	4822 130 30613
V 1413	BF199	4822 130 44154
V 1414	BF199	4822 130 44154
V 1416	BZX79-C5V1	4822 130 34233
V 1417	BFT45	5322 130 44603
V 1418	BF338	4822 130 44108
V 1419	BSX20	5322 130 40417
V 1421	BAW62	4822 130 30613
V 1422	BF450	4822 130 44237
V 1423	BFT45	5322 130 44603
V 1424	BZX79-C5V1	4822 130 34233
V 1426	BF338	4822 130 44108
V 1427	BZX79-C36	4822 130 34368
V 1428	BZX79-C36	4822 130 34368
V 1429	BZX79-C36	4822 130 34368
V 1431	BZX79-C75	4822 130 34685
V 1501	BC548C	4822 130 44196
V 1502	BAW62	4822 130 30613
V 1503	BAW62	4822 130 30613
V 1504	BAW62	4822 130 30613
V 1506	BAW62	4822 130 30613
V 1507	QA95	4822 130 30191
V 1508	BAW62	4822 130 30613
V 1509	BAW62	4822 130 30613
V 1511	BC548C	4822 130 44196
V 1512	BAW62	4822 130 30613
V 1514	BC548C	4822 130 44196
V 1516	BAW62	4822 130 30613
V 1517	BAW62	4822 130 30613
V 1518	BC558B	4822 130 44197
V 1519	BC548C	4822 130 44196
V 1521	BC548C	4822 130 44196

POSNR	DESCRIPTION	ORDERING CODE
V 1522	BC548C	4822 130 44196
V 1523	B5568	5322 130 44247
V 1524	BAV21	4822 130 30842
V 1526	BAV21	4822 130 30842
V 1527	BC548C	4822 130 44196
V 1528	BC558B	4822 130 44197
V 1601	BC548C	4822 130 44196
V 1602	BC548C	4822 130 44196
V 1603	BC548C	4822 130 44196
V 1604	BAW62	4822 130 30613
V 1651	BAW62	4822 130 30613
V 1652	BAW62	4822 130 30613
V 1653	BAW62	4822 130 30613
V 1654	BAW62	4822 130 30613
V 1655	BAW62	4822 130 30613
V 1656	BAW62	4822 130 30613
V 1657	BAW62	4822 130 30613
V 1658	BC558B	4822 130 44197
V 1659	BC558B	4822 130 44197
V 1661	BAW62	4822 130 30613
V 1662	BC558B	4822 130 44197
V 1663	BAW62	4822 130 30613
V 1664	BC558B	4822 130 44197
V 1666	BC558B	4822 130 44197
V 1667	BAW62	4822 130 30613
V 1668	BC548C	4822 130 44196

INTEGRATED CIRCUITS

POSNR	DESCRIPTION	ORDERING CODE
D 501	SL3145E	5322 130 34854
D 601	SL3145E	5322 130 34854
D 801	SL3145E	5322 130 34854
D 1001	CA3086	5322 209 86236
D 1101	CA3086	5322 209 86236
D 1201	N74S10N	5322 209 84954
D 1202	N74122N	5322 209 84231
D 1203	SN74S74N-00	5322 209 84183
D 1204	N74LS132N	5322 209 85201
D 1301	N74LS132N	5322 209 85201
D 1302	N74S00N	5322 209 84167

Additional partslist information:

V1: DY-125 GM-08	5322 131 24049	CRT with long persistence time
Amber contrast filter	5322 705 34232	

MISCELLANEOUS

POSNR	DESCRIPTION	ORDERING CODE
B 1	CQY24B/IV	4822 130 31144
E 1	Lamp 28V 80mA	5322 134 44177
E 2	Lamp 28V 80mA	5322 134 44177
F 201	Fuse 1,4A	4822 253 30023
F 202	Fuse 1,4A	4822 253 30023
K 501	Assy reed relais	5322 280 24131
K 601	Assy reed relais	5322 280 24131
K 1401	Assy reed relais	5322 280 24131
L 201	COIL	5322 281 64154
L 202	COIL	5322 281 64154
L 203	COIL	5322 281 64154
L 801	COIL	5322 157 51296
L 802	COIL	5322 157 51296
L 1501	ROTARY COIL	5322 150 14015
S9	ATTENUATOR SWITCH	5322 273 74011
S11	ATTENUATOR SWITCH	5322 273 74011
S13	DTB SWITCH	5322 273 44101
S15	MTB SWITCH	5322 273 54059
S 24		5322 272 10215
T 101	MAINS TRANSFORMER	5322 146 24166
T 201	COIL ASSY	5322 158 34074
T 202		5322 146 24163
	THERMAL FUSE	4822 252 20007
	3-POLE PLUG	4822 266 30071
	3-POLE SOCKET	4822 265 30121
	4-POLE PLUG	4822 266 30072
	4-POLE SOCKET	4822 265 30119
	6-POLE PLUG	4822 266 30073
	6-POLE SOCKET	4822 265 30117
	7-POLE PLUG	4822 266 40057
	7-POLE SOCKET	4822 265 40119



8. CIRCUIT DIAGRAMS AND PRINTED CIRCUIT BOARD LAY-OUTS

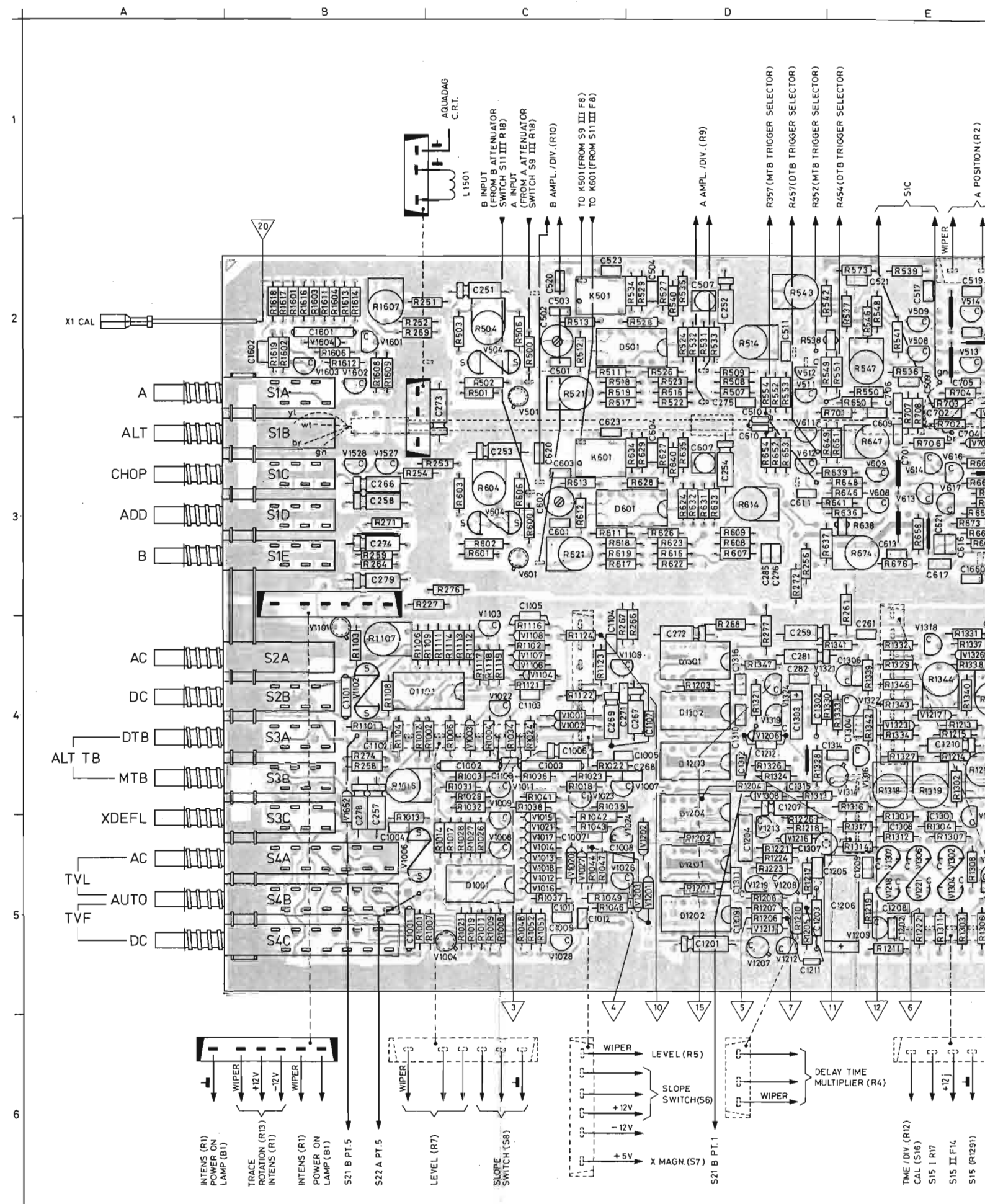

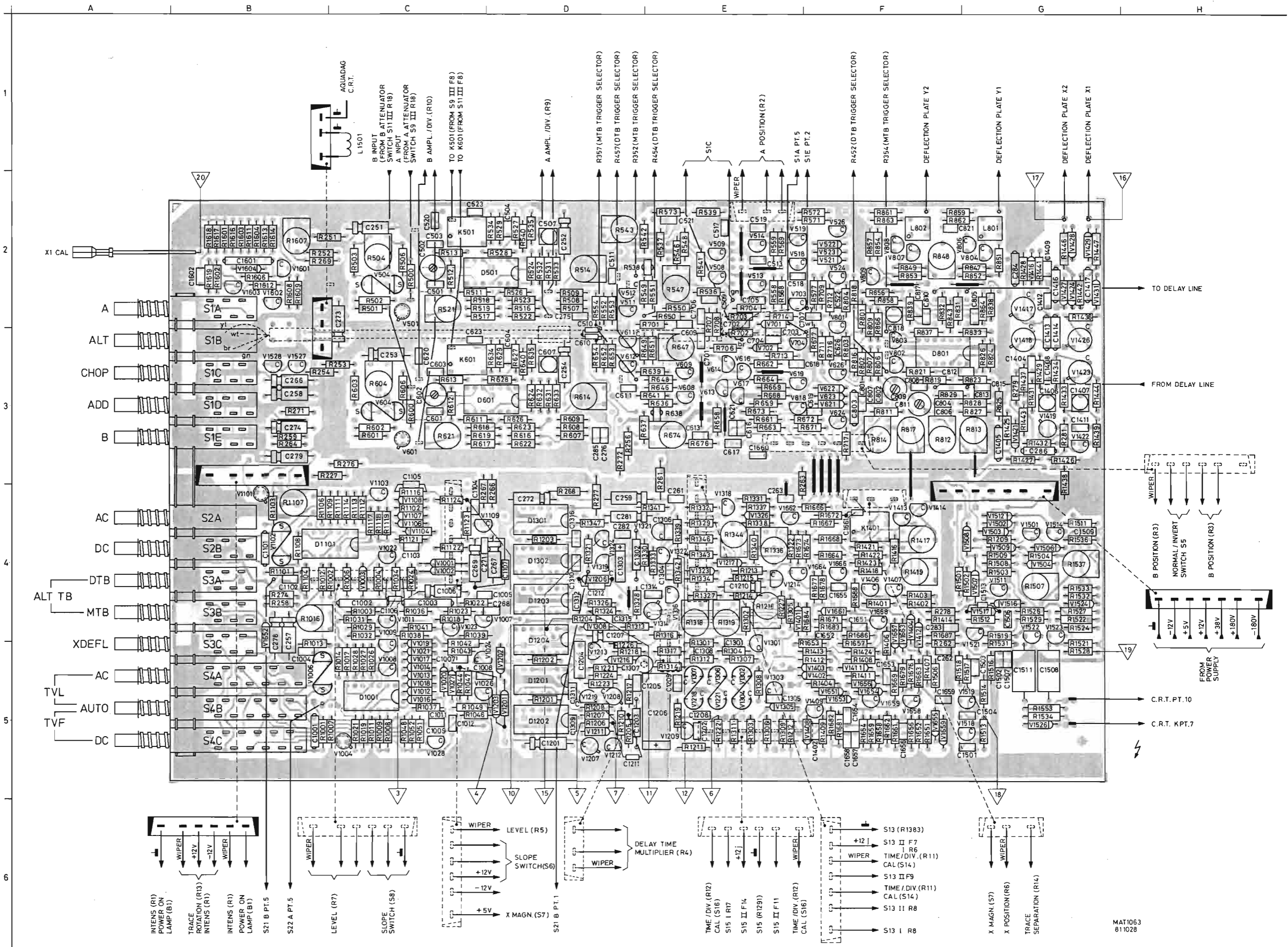

Fig. 8.1. Vertical amplifier unit with rear side tracks

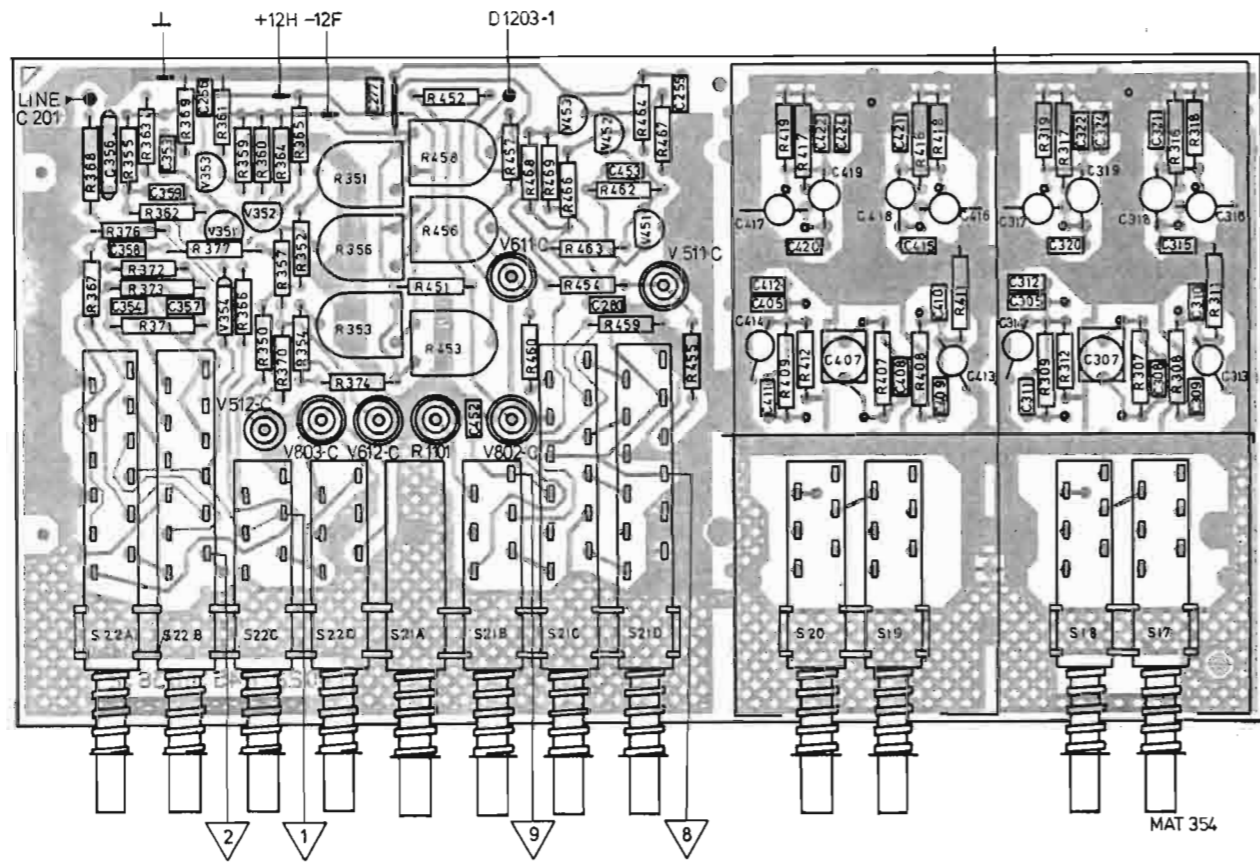
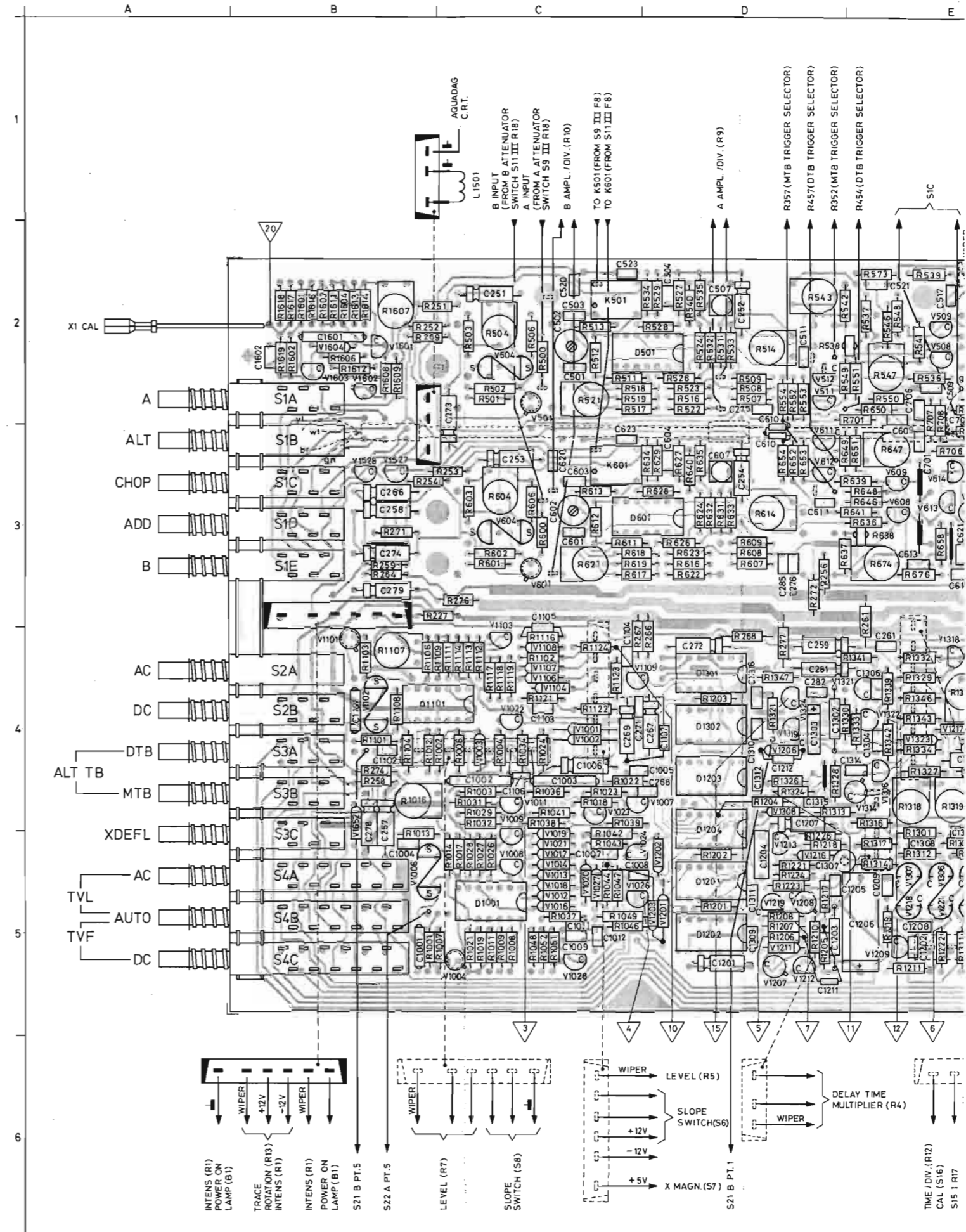

Fig. 8.2. Vertical attenuator unit



6

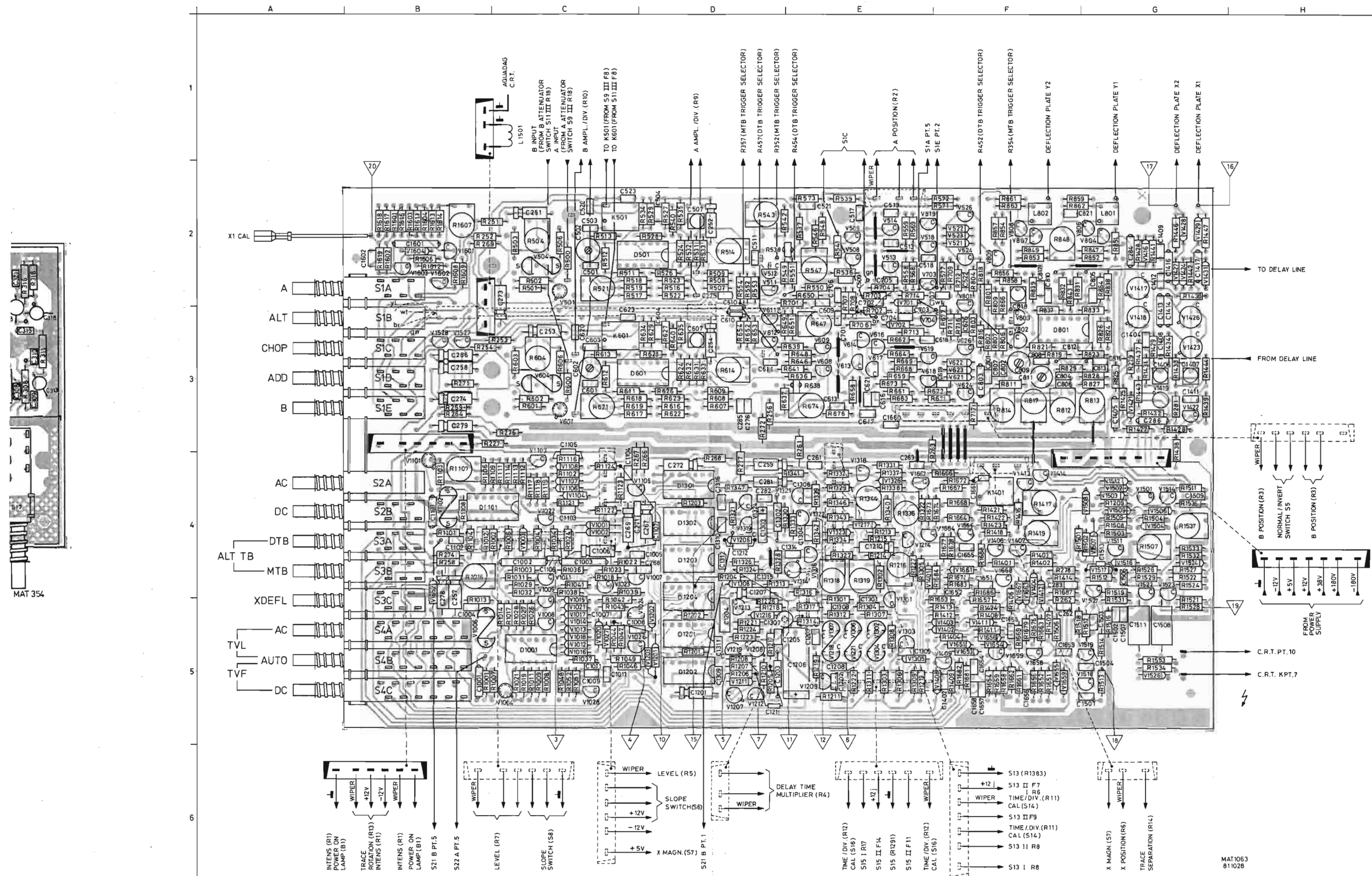

Fig. 8.4. Vertical amplifier unit with upper side tracks

MAT1063
811028

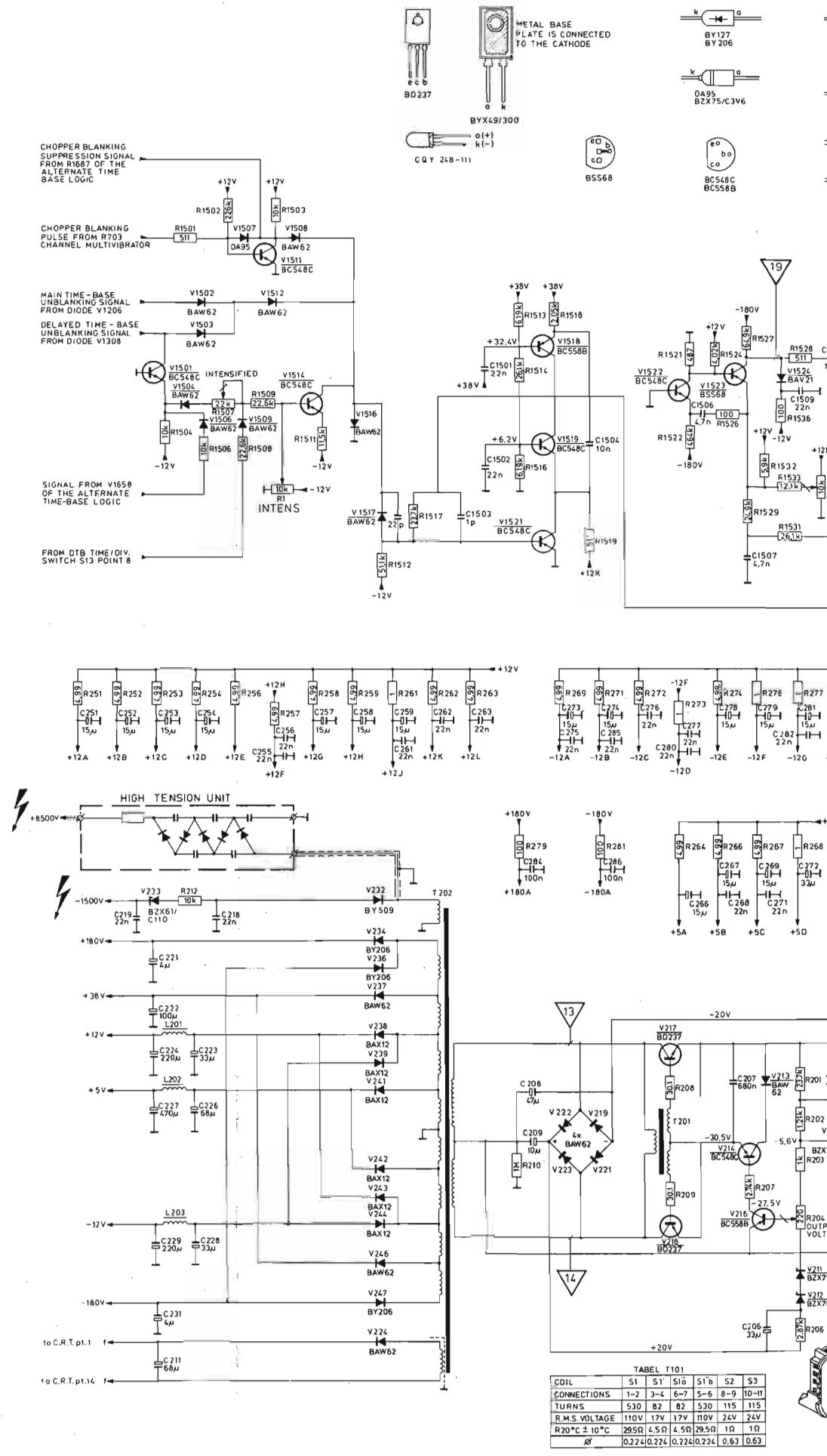
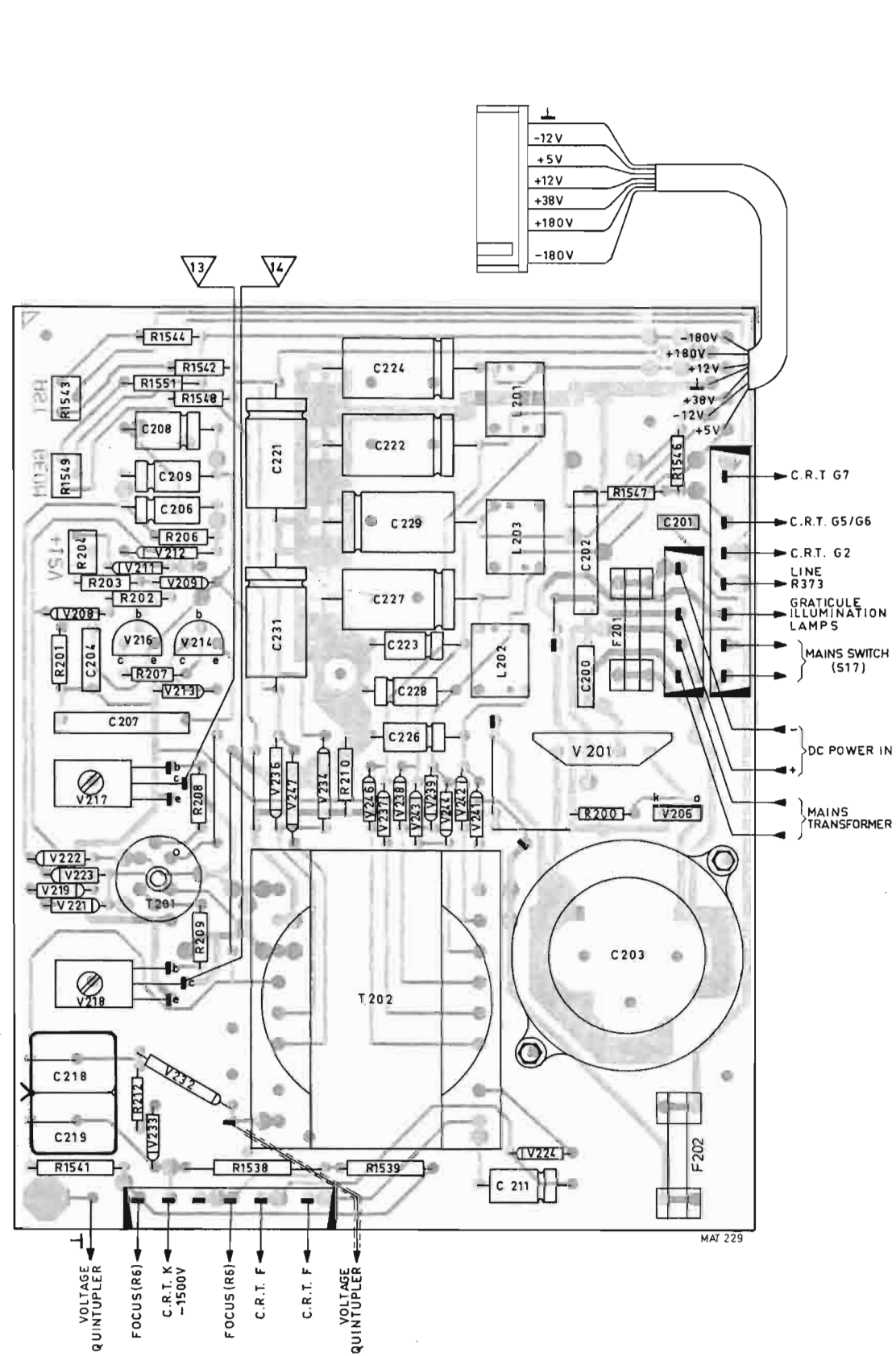
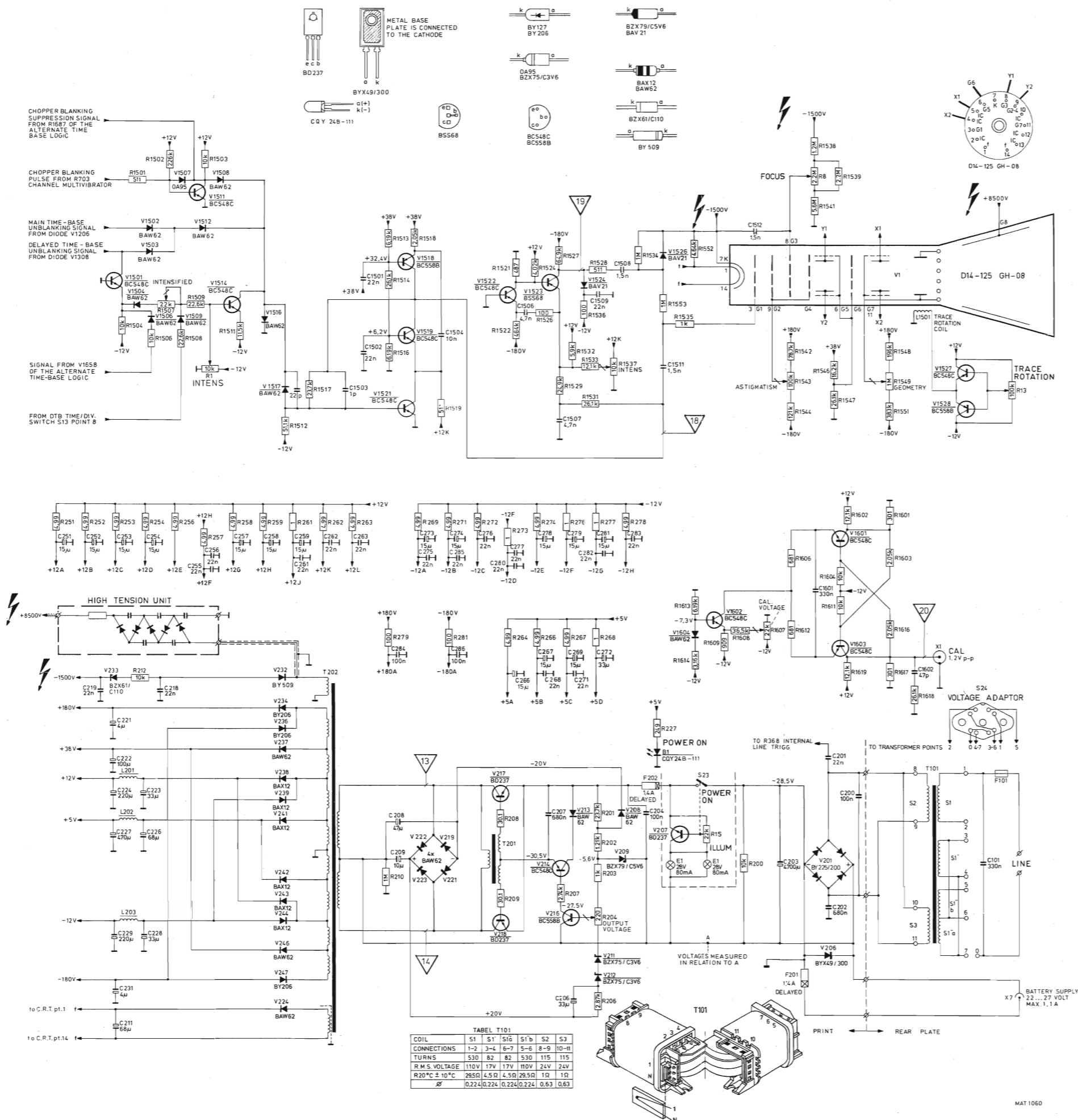

Fig. 8.3. Power supply unit

TABEL T101

COIL	S1	S1	S1b	S1b	S2	S3
CONNECTIONS	1-2	3-4	6-7	5-6	8-9	10-11
TURNS	530	82	82	530	115	115
R.M.S. VOLTAGE	110V	17V	17V	110V	24V	24V
R20°C ± 10°C	29.5Ω	4.5Ω	4.5Ω	29.5Ω	1Ω	1Ω
β	0.274	0.274	0.274	0.274	0.63	0.63



FOR THE SETTINGS OF THE OSCILLOSCOPE UNDER TEST SEE CHAPTER 6.6.4
FOR MEASURING THESE WAVE FORMS A PROBE 10:1 MUST BE USED

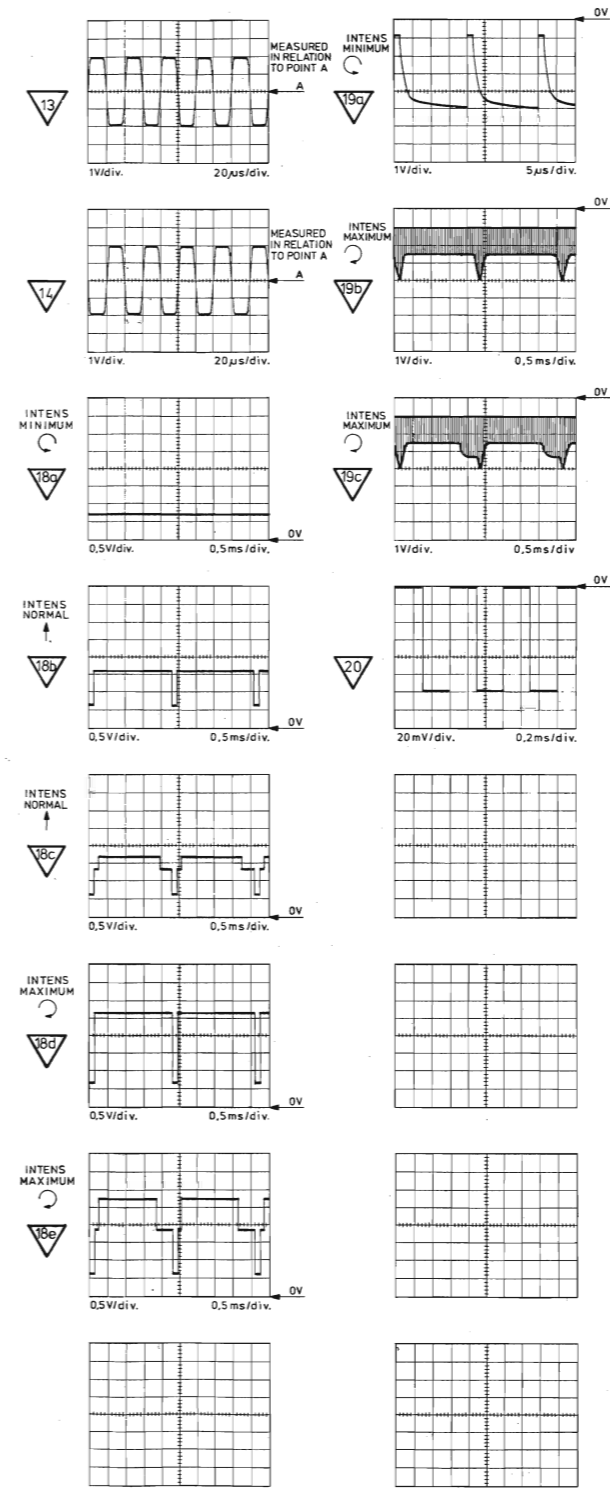
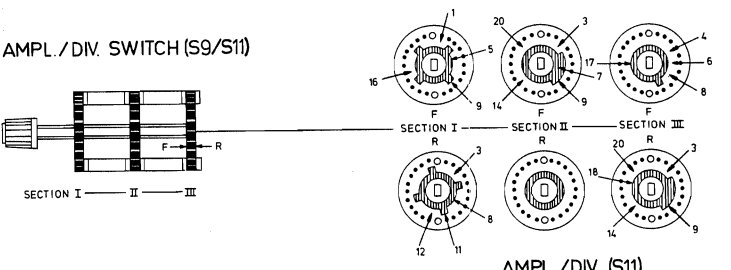
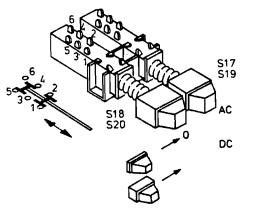
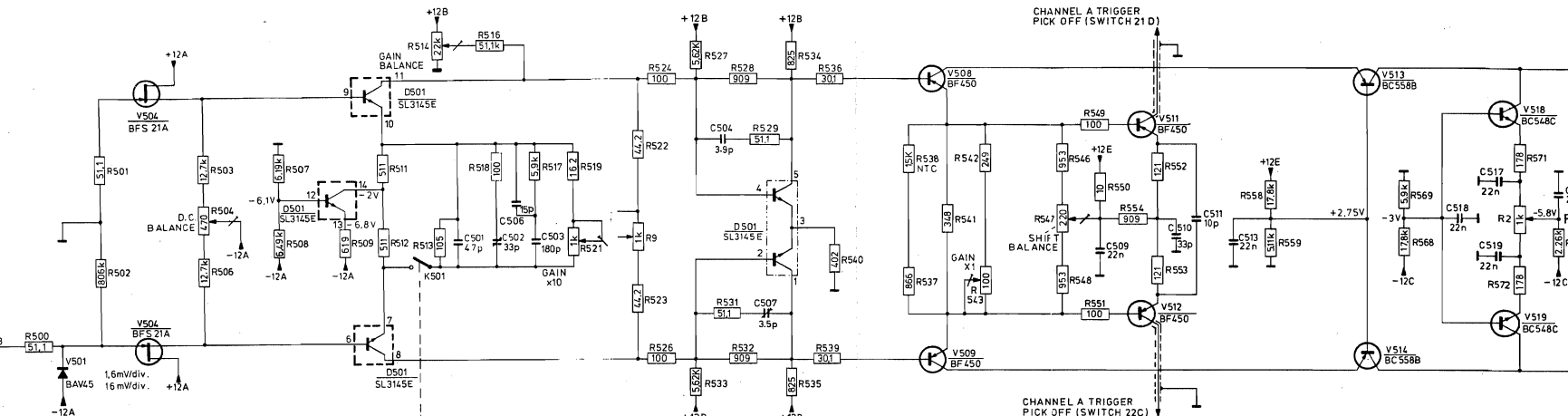
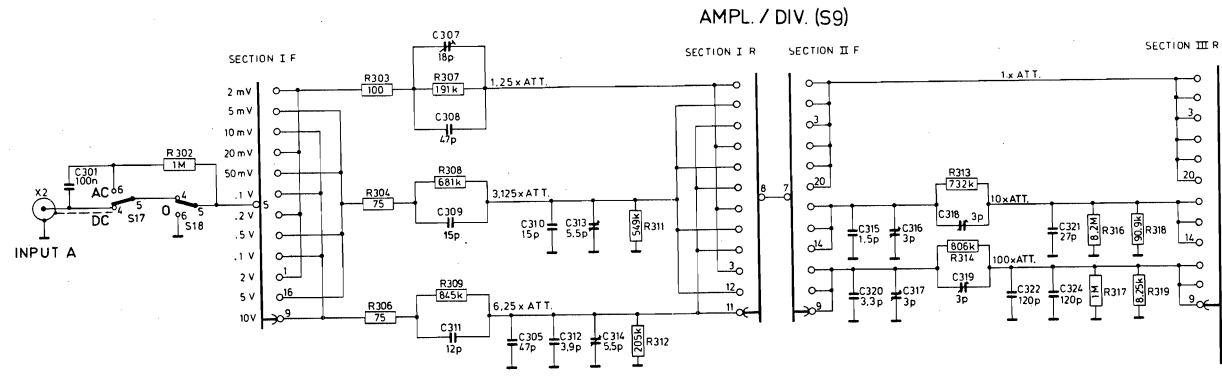
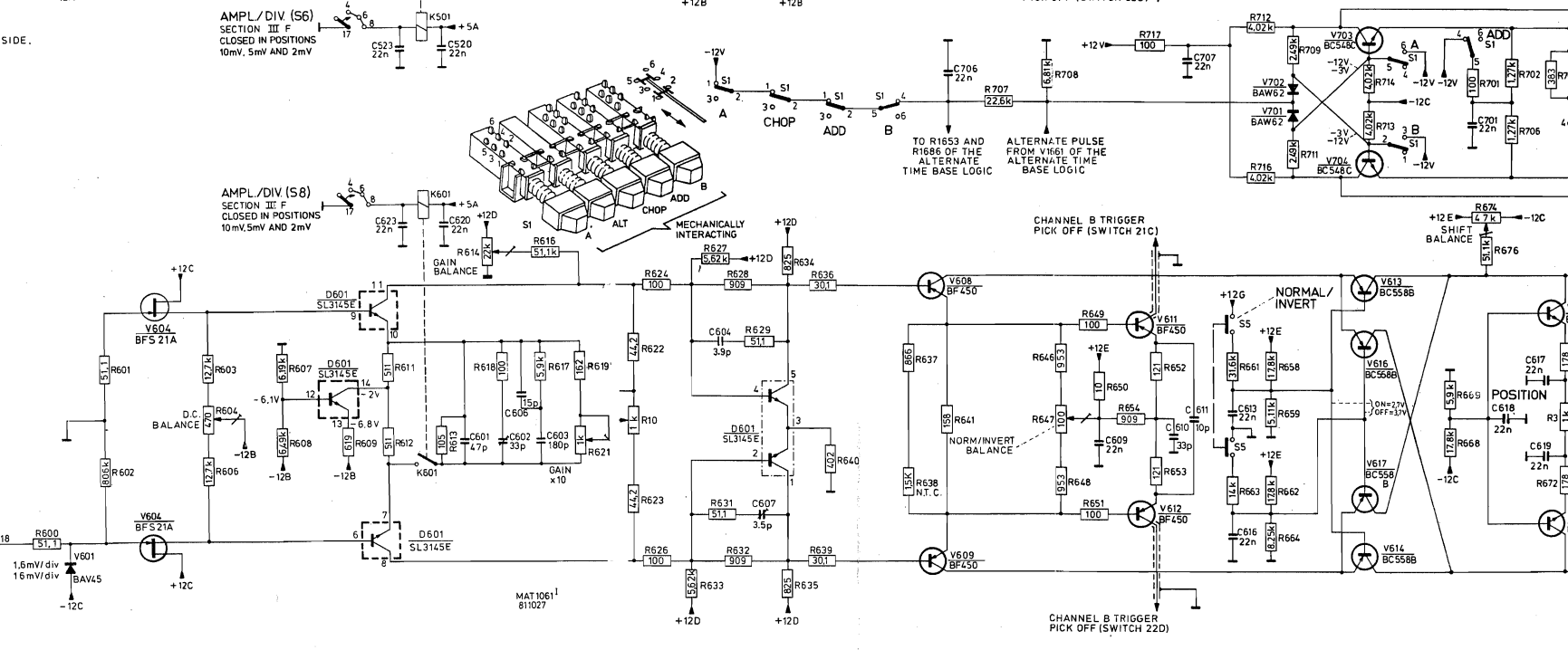
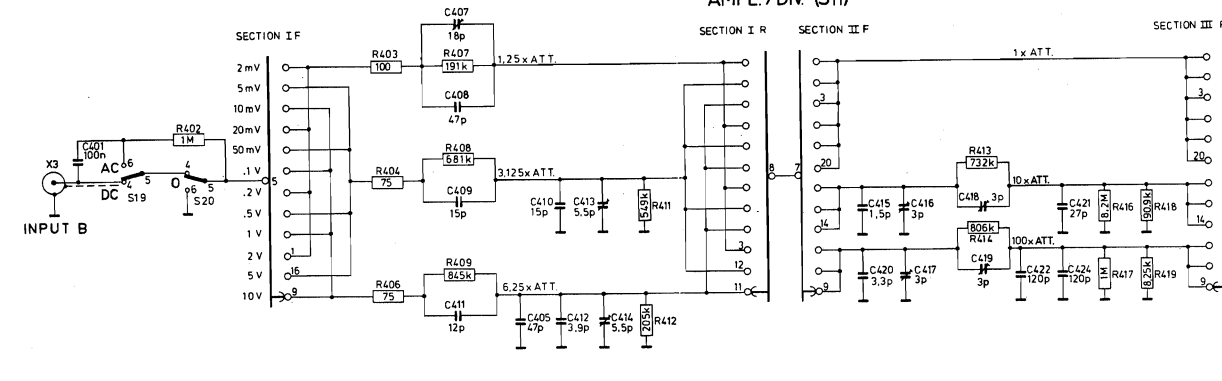

Fig. 8.5. Circuit diagram of power supply, Z-amplifier and C.R.T. circuit



BOTH FRONT AND REAR SECTIONS OF THE AMPL. DIV. SWITCHES ARE SEEN FROM THE FRONT SIDE.

ALL PUSHBUTTONS ARE DRAWN IN THE RELEASED POSITIONS.



MAT 1061
811027

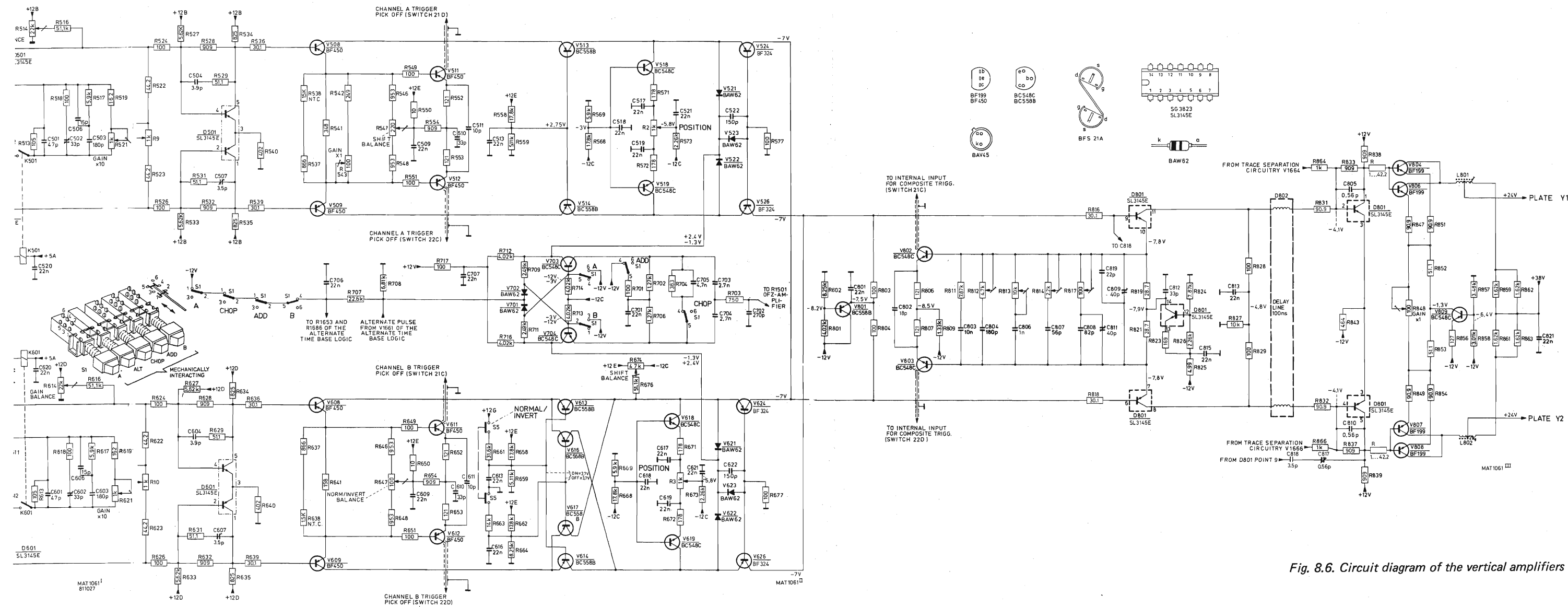
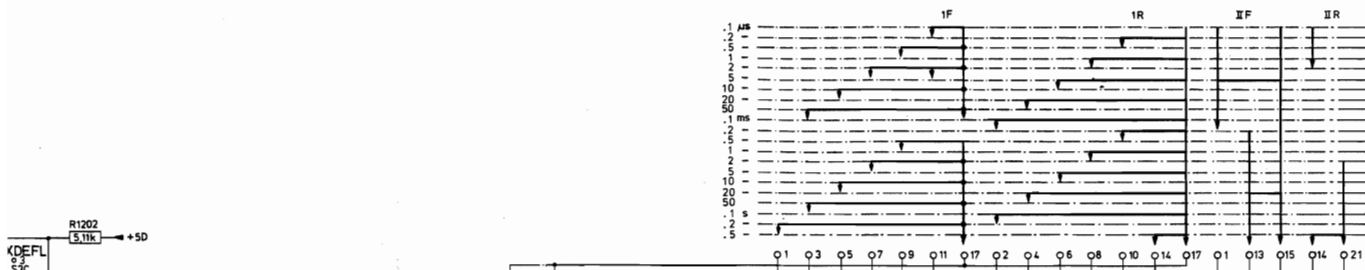
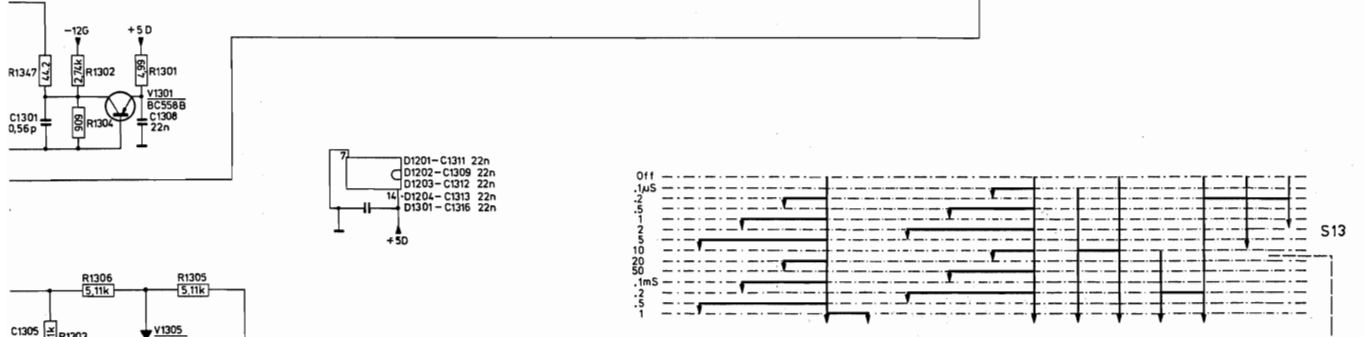
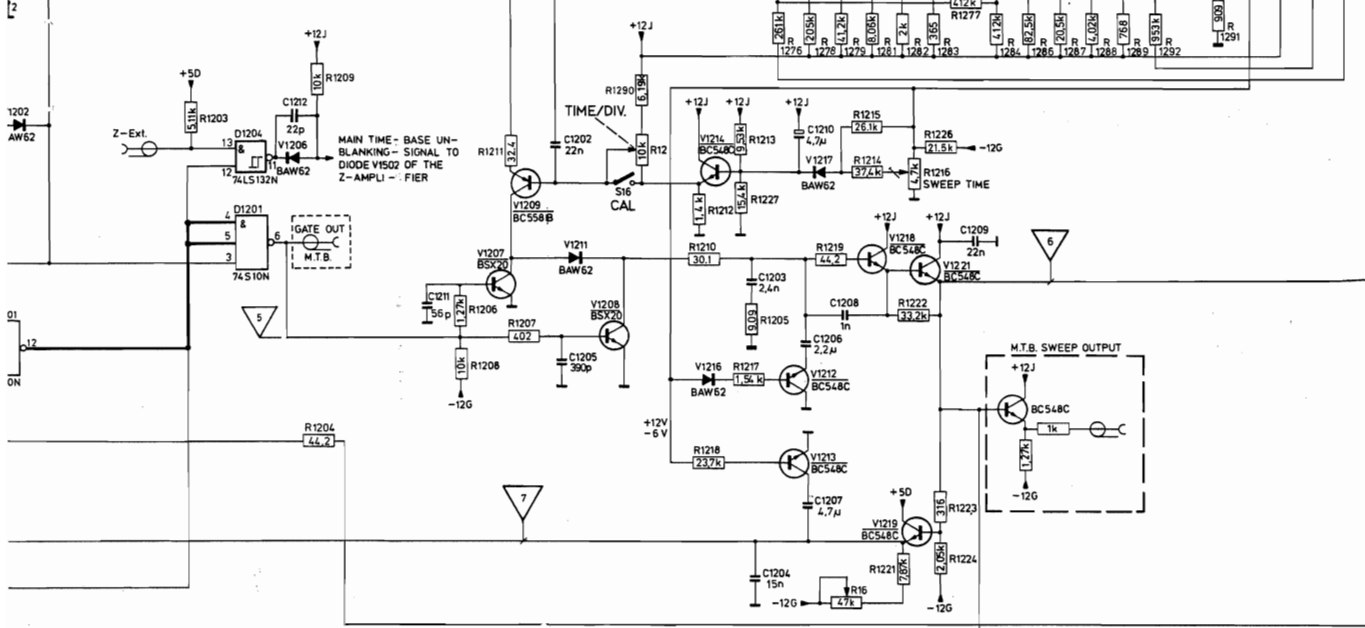
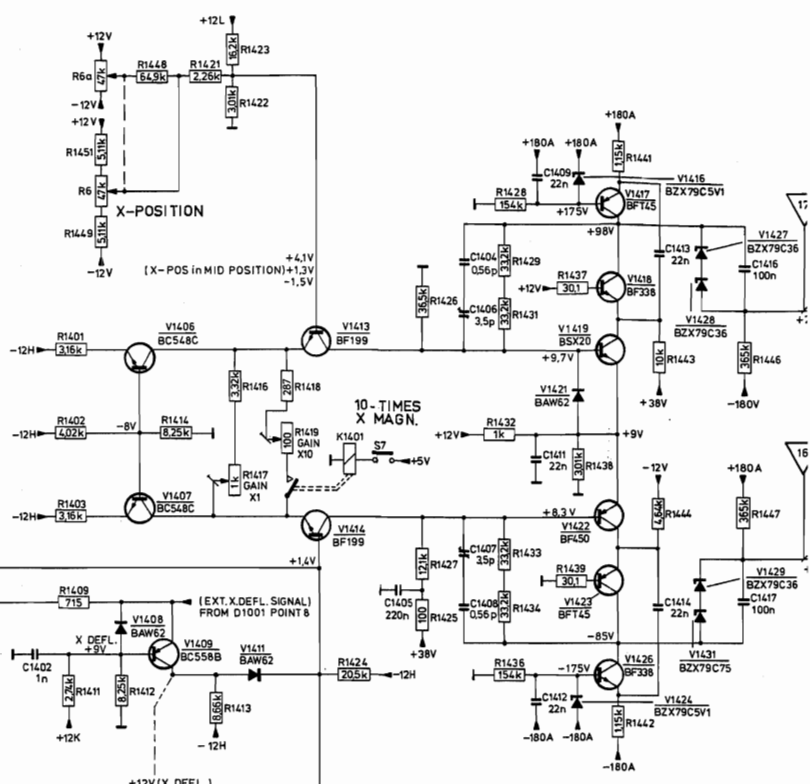
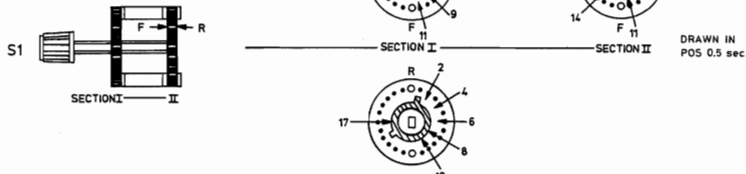

Fig. 8.6. Circuit diagram of the vertical amplifiers



TIME / DIV. SWITCH (S15)



TIME / DIV. SWITCH (S13)

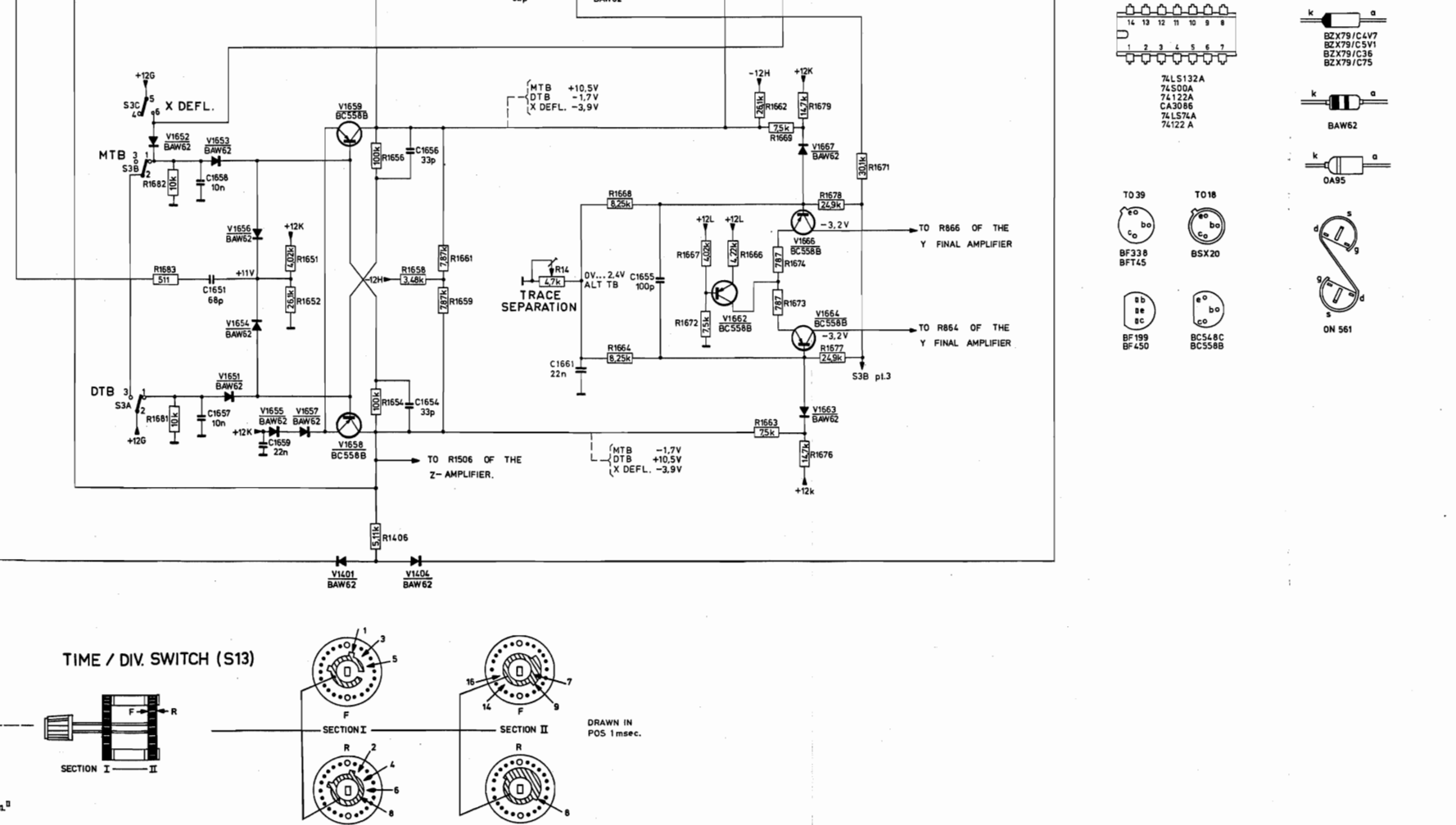
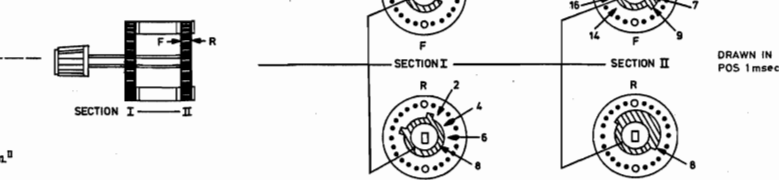

- 74LS132A
- 74LS00A
- 74LS122A
- CA3086
- 74LS74A
- 74LS122A
- BZ79/C4V7
- BZ79/C36
- BZ79/C75
- BAW62
- OA95
- TO 39
- BF338
- BF199
- BF450
- TO 18
- BSX20
- BC548C
- BC558B
- ON 561

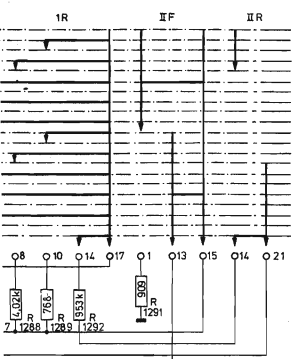

TIME / DIV. SWITCH (S15)

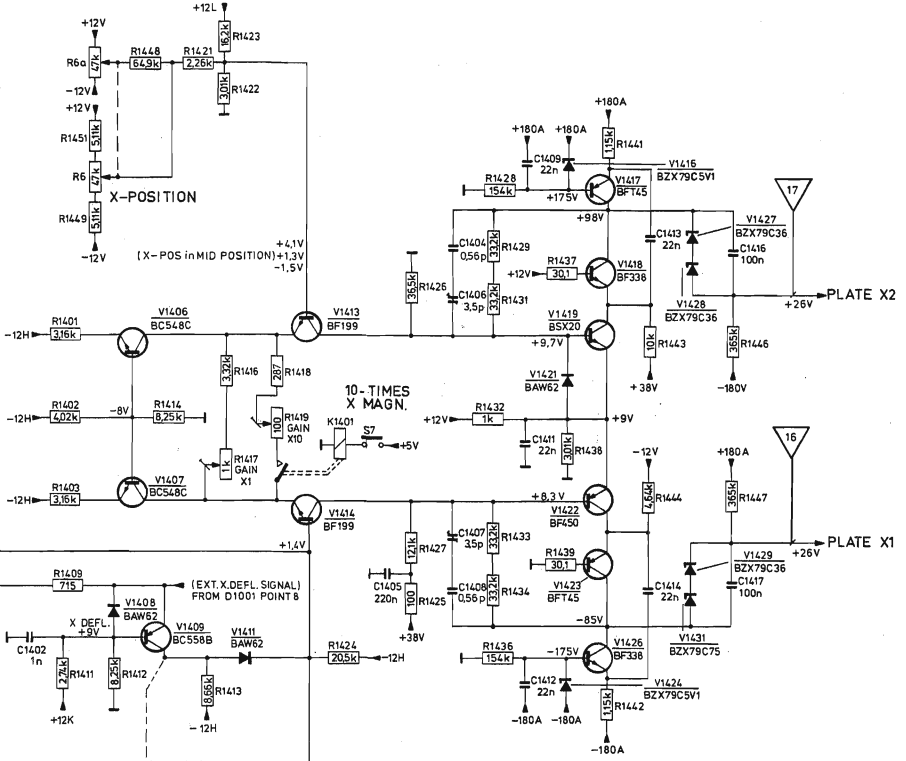
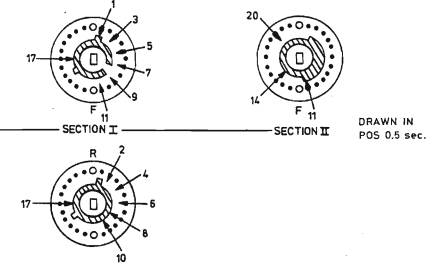

FOR THE SETTINGS OF THE OSCILLOSCOPE UNDER TEST SEE CHAPTER 6.6.4.

FOR MEASURING THESE WAVE-FORMS A PROBE 10:1 MUST BE USED

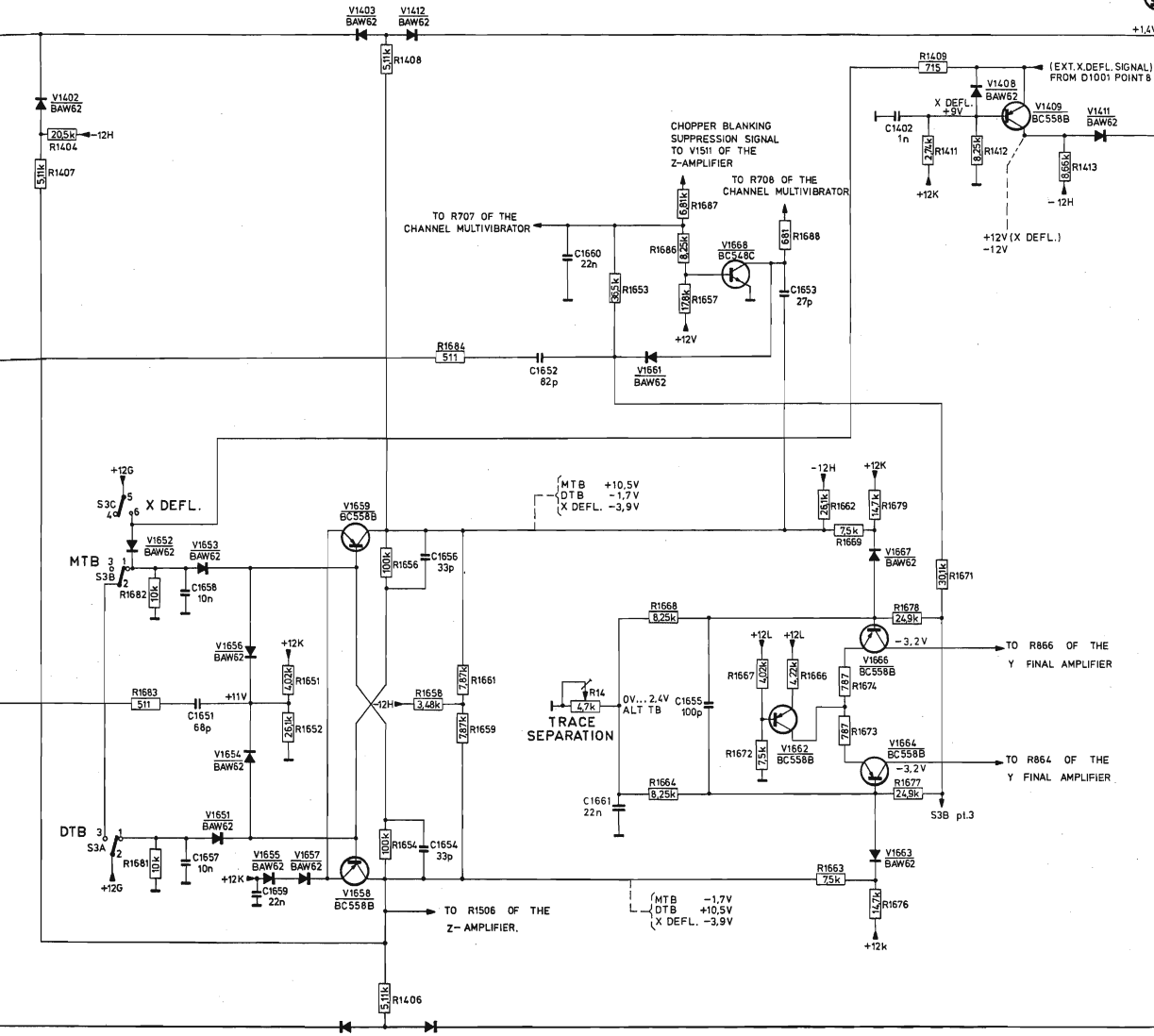
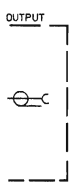
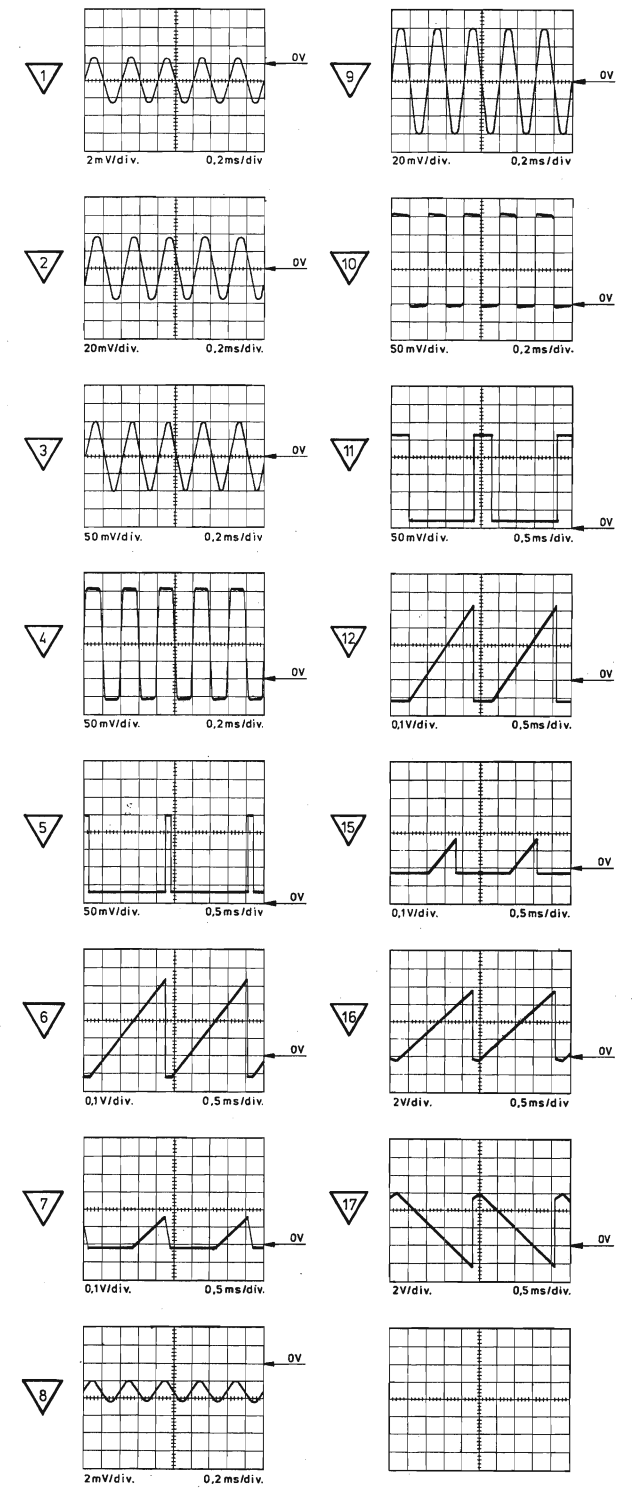

TIME / DIV. SWITCH (S13)

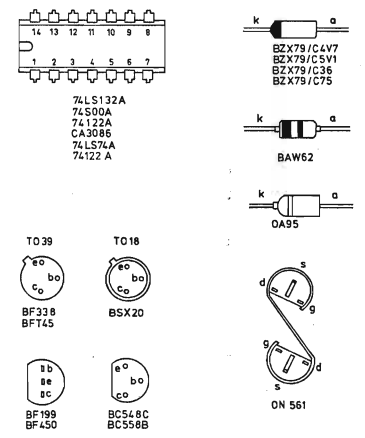
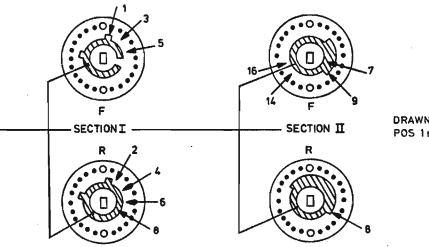

Fig. 8.7. Circuit diagram of the main and delayed time-bases

MODIFICATIONS

MODIFICATIONS

CODING SYSTEM OF FAILURE REPORTING FOR QUALITY
ASSESSMENT OF T & M INSTRUMENTS
(excl. potentiometric recorders)

The information contents of the coded failure description is necessary for our computerized processing of quality data.

Since the reporting of repair and maintenance routines must be complete and exact, we give you an example of a correctly filled-out PHILIPS SERVICE Job sheet.

①	②	③	④
Country	Day Month Year	Typenumber /Version	Factory/Serial no.
3 2	1 5 0 4 7 5	O P M 3 2 6 0 0 2	D O 0 0 7 8 3

CODED FAILURE DESCRIPTION

⑤		⑥		⑦																																																										
Nature of call		Location	Component/sequence no.	Category	Working time ⑧																																																									
<input type="checkbox"/> Installation <input type="checkbox"/> Pre sale repair <input type="checkbox"/> Preventive maintenance <input checked="" type="checkbox"/> Corrective maintenance <input type="checkbox"/> Other	<table border="1" style="width: 100%; height: 100%; border-collapse: collapse;"> <tr><td> </td><td> </td><td> </td><td> </td></tr> <tr><td> </td><td> </td><td> </td><td> </td></tr> <tr><td>0</td><td>0</td><td>2</td><td>1</td></tr> <tr><td> </td><td> </td><td> </td><td> </td></tr> <tr><td> </td><td> </td><td> </td><td> </td></tr> </table>									0	0	2	1									<table border="1" style="width: 100%; height: 100%; border-collapse: collapse;"> <tr><td>T</td><td>S</td><td>0</td><td>6</td><td>0</td><td>7</td></tr> <tr><td>R</td><td>0</td><td>0</td><td>6</td><td>3</td><td>1</td></tr> <tr><td>9</td><td>9</td><td>0</td><td>0</td><td>0</td><td>1</td></tr> <tr><td> </td><td> </td><td> </td><td> </td><td> </td><td> </td></tr> <tr><td> </td><td> </td><td> </td><td> </td><td> </td><td> </td></tr> </table>	T	S	0	6	0	7	R	0	0	6	3	1	9	9	0	0	0	1													<table border="1" style="width: 100%; height: 100%; border-collapse: collapse;"> <tr><td>5</td></tr> <tr><td>2</td></tr> <tr><td>4</td></tr> <tr><td> </td></tr> <tr><td> </td></tr> </table>	5	2	4			<input checked="" type="checkbox"/> Job completed <input type="checkbox"/> Working time ⑧ <table border="1" style="width: 100%; height: 100%; border-collapse: collapse;"> <tr><td> </td><td>1</td><td>2</td></tr> </table> Hrs		1	2
0	0	2	1																																																											
T	S	0	6	0	7																																																									
R	0	0	6	3	1																																																									
9	9	0	0	0	1																																																									
5																																																														
2																																																														
4																																																														
	1	2																																																												

Detailed description of the information to be entered in the various boxes:

①Country: 3 2 = Switzerland

②Day Month Year 1 5 0 4 7 5 = 15 April 1975

③Type number/Version O P M 3 2 6 0 0 2 = Oscilloscope PM 3260, version 02 (in later oscilloscopes this number is placed in front of the serial no)

④Factory/Serial number D O 0 0 7 8 3 = DO 783 These data are mentioned on the type plate of the instrument

⑤ Nature of call: Enter a cross in the relevant box

⑥ Coded failure description

<p>Location</p> <table border="1" style="width: 100%; height: 100%; border-collapse: collapse;"> <tr><td> </td><td> </td><td> </td><td> </td></tr> </table> <p>These four boxes are used to isolate the problem area. Write the code of the part in which the fault occurs, e.g. unit no or mechanical item no of this part (refer to 'PARTS LISTS' in the manual). Example: 0001 for Unit 1 000A for Unit A 0075 for item 75</p> <p>If units are not numbered, do not fill in the four boxes; see Example Job sheet.</p>					<p>Component/sequence no.</p> <table border="1" style="width: 100%; height: 100%; border-collapse: collapse;"> <tr><td> </td><td> </td><td> </td><td> </td><td> </td><td> </td></tr> </table> <p>These six boxes are intended to pinpoint the faulty component. A. Enter the component designation as used in the circuit diagram. If the designation is alfa-numeric, the letters must be written (starting from the left) in the two left-hand boxes and the figures must be written (in such a way that the last digit occupies the right-most box) in the four right-hand boxes. B. Parts not identified in the circuit diagram: 990000 Unknown/Not applicable 990001 Cabinet or rack (text plate, emblem, grip, rail, graticule, etc.) 990002 Knob (incl. dial knob, cap, etc.) 990003 Probe (only if attached to instrument) 990004 Leads and associated plugs 990005 Holder (valve, transistor, fuse, board, etc.) 990006 Complete unit (p.w. board, h.t. unit, etc.) 990007 Accessory (only those without type number) 990008 Documentation (manual, supplement, etc.) 990009 Foreign object 990099 Miscellaneous</p>							<p>Category</p> <table border="1" style="width: 100%; height: 100%; border-collapse: collapse;"> <tr><td> </td></tr> </table> <p>0 Unknown, not applicable (fault not present, intermittent or disappeared) 1 Software error 2 Readjustment 3 Electrical repair (wiring, solder joint, etc.) 4 Mechanical repair (polishing, filing, remachining, etc.) 5 Replacement (of transistor, resistor, etc.) 6 Cleaning and/or lubrication 7 Operator error 8 Missing items (on pre-sale test) 9 Environmental requirements are not met</p>	

⑦ Job completed: Enter a cross when the job has been completed.

⑧ Working time: Enter the total number of working hours spent in connection with the job (excluding travelling, waiting time, etc.), using the last box for tenths of hours.

 1 2 = 1,2 working hours (1 h 12 min.)



PHILIPS

SERVICE

Scientific & Analytical Equipment
Test & Measuring Instruments
Industrial Automation
Advanced Automation Systems
Welding

Scientific &
Industrial
Equipment
Division

820420

OSC 122

Supplement for the Service Manual 9499 445 00611 of the PM 3217/PM 3217U.

Already published: -

Subject: Modification of the final amplifier for the PM 3217(U)/02

1. GENERAL

To obtain a better performance of the square wave response, the final amplifier is completely re-designed.

The new final amplifier is mounted on a separate printed circuit board which is located between the cathode ray tube and the inner-chassis.

This means that several components on the original large printed circuit board are not used and thus deleted.

The diagrams and print lay-outs in this sheet give all information of the new situation.

2. DESCRIPTION OF THE NEW FINAL AMPLIFIER

The output of the delay line is applied to transistor array D802(6,7,8) and (9,10,11) via terminators R837, R843. Together with the impedance across D802(8,7) and (9,10) this termination corresponds with the characteristic impedance of the delay line. The constant current source D802(12,13,14) is switched in the circuit to supply this parallel feed-back stage.

The output of the stage is applied to the series feed-back stage V811, V812 which drives the power stage V809, V813. The Y-plates of the c.r.t. are controlled by the output voltage of the power transistors.

To obtain a good square wave response, a correction network is switched between the emitters of V811 and V812.

The value of the collector resistance of the final power stage is 790 Ohm which is split-up into 4 resistors, switched in parallel to deviate the heat dissipation.

9499 448 20411

PRINTED IN THE NETHERLANDS

3. ADJUSTING PROCEDURE

In chapter 5.4. "SURVEY OF ADJUSTING ELEMENTS AND AUXILIARY EQUIPMENT" page 45 under "Square-wave response final amplifier" the following changes should be made: C508 must be C607 (C507). Rise time of the square wave calibration generator must be ≤ 1 ns.

The following part of the adjusting procedure replaces page 52 of the PM 3217 Service Manual.

3.1 Input capacitance

- Apply a square-wave voltage with an amplitude as indicated in the following table, frequency 10 kHz and a rise time < 100 ns to the B(A) input socket X3(X2) via a dummy probe.

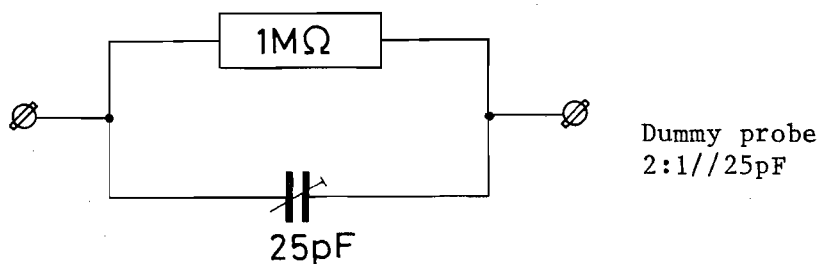

- Check that the pulse top errors do not exceed $\pm 0,5$ subdivision and that the trace height is 6 divisions $\pm 0,5$ subdivision.

B(A) Ampl.	YB(YA) input signal	Adjuster
2 mV	24 mV	Cv dummy
5 mV	60 mV	Cv dummy
10 mV	120 mV	Cv dummy

- Check that the difference in input capacitance do not exceed 1 pF.
- Remove the input signal.

3.2 Square-wave response

- Depress B of S1.
 - Set the B AMPL/DIV switch to 20 mV/div.
 - Depress B of S16.
 - Set the TIME/DIV switch to .1 μ s/div.
 - Apply a square-wave voltage of 120 mVpp (or 300 mVpp), frequency 1 Mhz and a rise time <1 ns to the B input socket X3.
 - Set the adjusting elements C809, C811, R817 and C607 on the Amplifier unit and C824, C826 and R857 on the Final Amplifier unit in their mid-position.
 - Set level *A*(fig. below) of the square-wave signal to the lowest horizontal graticule line.
 - Adjust L801 and L802 for minimal pulse aberrations.
 - Check the square-wave response; pulse top errors may not exceed 0,5 subdiv. in the 20 mV, 50 mV and INVERT position of channel B.
- If necessary, readjust the adjusting elements according to the figure below.

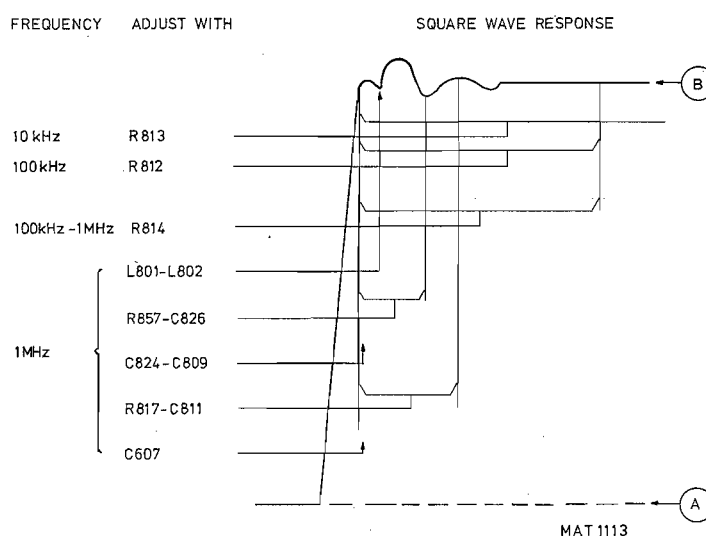

note: The cores of L801 and L802 must be turned into the coils as far as possible (not necessarily equal).

- Set level *B* of the square-wave signal to the lowest horizontal graticule line.
- Check that the pulse top errors do not exceed ± 1 subdivision.
- Check and readjust the square-wave response according to the table below.

Channel	AMPL/DIV	Input signal	Trace height	Rep rate	Adj.with	Max. error
B	2mV/div	12 mV	6 div.	1 MHz	C602	0,5 subdiv.
A	20mV/div	120 mV	6 div.	1 MHz	C507	0,5 subdiv.
A	2mV/div	12 mV	6 div.	1 MHz	C502	0,5 subdiv.

4. PARTS LIST

<u>POSNR</u>	<u>DESCRIPTION</u>	<u>ORDERING CODE</u>
CAPACITORS		
C 818	10NF 100V	4822 122 31414
C 819	3,3PF 0,25P 100V	4822 122 31041
C 821	10NF 100V	4822 122 31414
C 822	3,3PF 0,25P 100V	4822 122 31041
C 823	10NF 100V	4822 122 31414
C 824	39PF 2% 100V	4822 122 31069
C 826	27PF 100V	5322 125 50164
C 827	39PF 2% 100V	4822 122 31069
C 828	10NF 100V	4822 122 31414
C 829	10NF 100V	4822 122 31414
C 831	10PF 2% 100V	5322 122 31566
C 832	10NF 100V	4822 122 31414
C 833	10NF 100V	4822 122 31414
C 836	100PF 2% 100V	4822 122 31504
C 837	100PF 2% 100V	4822 122 31504
C 838	10NF 100V	4822 122 31414
C 839	10NF 100V	4822 122 31414

RESISTORS

R 831	8K25 0,5% 0,4W	5322 116 51498
R 832	590E 1% 0,4W	5322 116 50561
R 833	100E 1% 1/8W	5322 116 54469
R 834	1K 0,5% 0,4W	4822 116 51235
R 836	909E 0,5% 0,4W	5322 116 55278
R 837	82E5 1% 0,4W	5322 116 54462
R 838	12K1 1% 0,4W	5322 116 50572
R 839	11K 1% 0,4W	5322 116 54623
R 841	237E 1% 0,4W	5322 116 50679
R 842	464E 1% 0,4W	5322 116 50536
R 843	82E5 1% 0,4W	5322 116 54462
R 844	1K 0,5% 0,4W	4822 116 51235
R 846	909E 0,5% 0,4W	5322 116 55278
R 847	100E 1% 1/8W	5322 116 54469
R 848	8K25 0,5% 0,4W	5322 116 51498
R 849	590E 1% 0,4W	5322 116 50561
R 851	31E6 1% 0,4W	5322 116 54034
R 852	31E6 1% 0,4W	5322 116 54034
R 853	162E 1% 0,4W	5322 116 50417
R 854	470E 20% 0,75W	5322 101 10379
R 856	1E 1% 0,4W	4822 116 51179
R 857	100E 20% 0,75W	5322 101 10378
R 858	147E 1% 1/8W	5322 116 50766
R 859	464E 1% 0,4W	5322 116 50536
R 861	100E 1% 1/8W	5322 116 54469
R 862	205E 1% 0,4W	5322 116 50669
R 863	464E 1% 0,4W	5322 116 50536
R 864	100E 1% 1/8W	5322 116 54469
R 866	147E 1% 1/8W	5322 116 50766

POSNR	DESCRIPTION	ORDERING CODE
R 867	2K15 1% 0,4W	5322 116 50767
R 868	100E 1% 1/8W	5322 116 54469
R 869	2K15 1% 0,4W	5322 116 50767
R 871	3K16 1% 1/8W	5322 116 50579
R 872	3K16 1% 1/8W	5322 116 50579
R 873	3K16 1% 1/8W	5322 116 10579
R 874	3K16 1% 1/8W	5322 116 50579
R 876	3K16 1% 1/8W	5322 116 50579
R 877	3K16 1% 1/8W	5322 116 50579
R 878	3K16 1% 1/8W	5322 116 50579
R 879	3K16 1% 1/8W	5322 116 50579
R 881	5E11 1% 0,4W	5322 116 54192
R 882	1E 1% 0,4W	4822 116 51179
R 883	1E 1% 0,4W	4822 116 51179
R 884	5E11 1% 0,4W	5322 116 54192
R 886	5E11 1% 0,4W	5322 116 54192
R 887	5E11 1% 0,4W	5322 116 54192
R 888	5E11 1% 0,4W	5322 116 54192
R 889	5E11 1% 0,4W	5322 116 54192

SEMI-CONDUCTORS

V 809	BFW16A	5322 130 44015
V 811	BFQ24	5322 130 41664
V 812	BFQ24	5322 130 41664
V 813	BFW16A	5322 130 44015
V 814	BZX79-C4V3	4822 130 31346

INTEGRATED CIRCUIT

D 802	OQ 0127	5322 209 80992
-------	---------	----------------

MISCELLANEOUS

A1101	Y-FINAL AMPL UNIT	5322 216 51017
L 801	COIL	5322 157 51486
L 802	COIL	5322 157 51486

5. CIRCUIT DIAGRAMS AND PRINT LAY OUTS

The following items in the circuit diagram (fig. 8.5.) are changed:
 C501 and C601 old 47pF new 33pF ordering code 4822 122 31067
 C502 and C602 old 22pF new 40pF ordering code 4822 125 50092
 R303 and R304 old 100E new 75 E ordering code 5322 116 54459
 R518 and R618 old 100E new 46E4 ordering code 5322 116 50492
 Added: A coil in series with R303 (403)

A capacitor of 10pF in parallel with R303 (403) 4822 122 31054

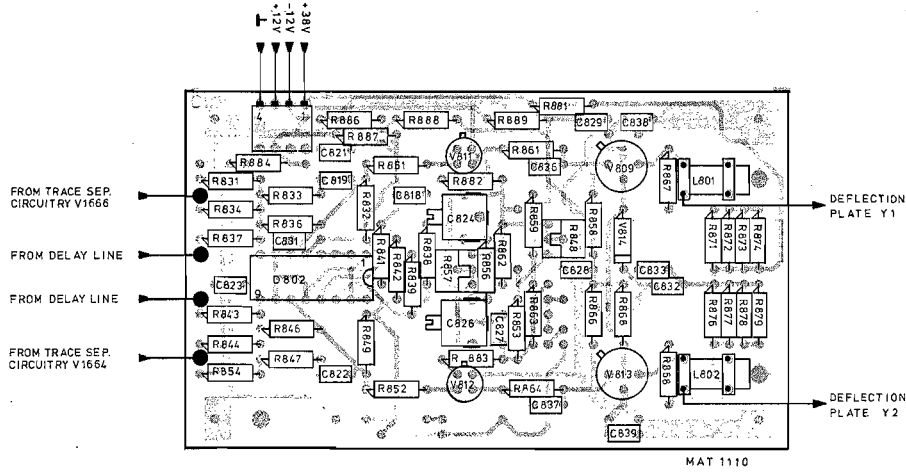

Fig. 1. Print lay out of the new final amplifier.

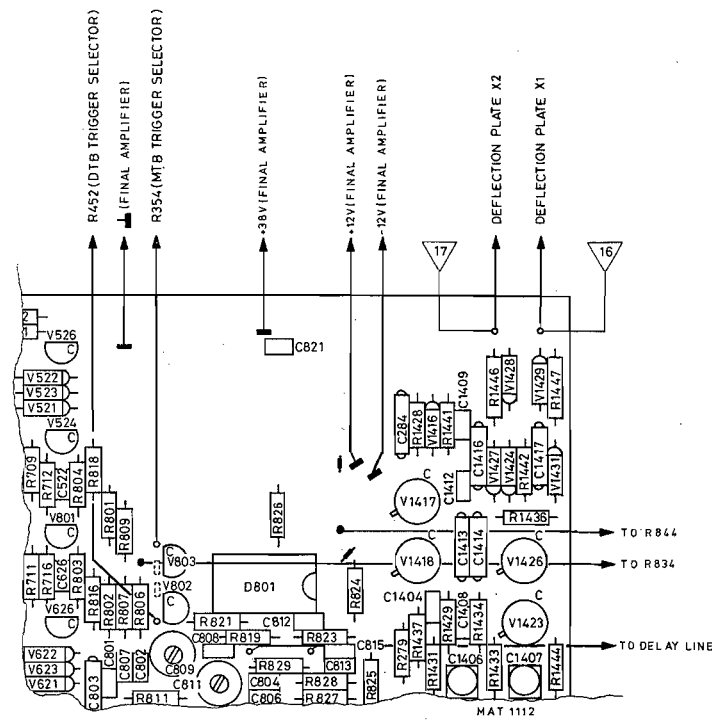
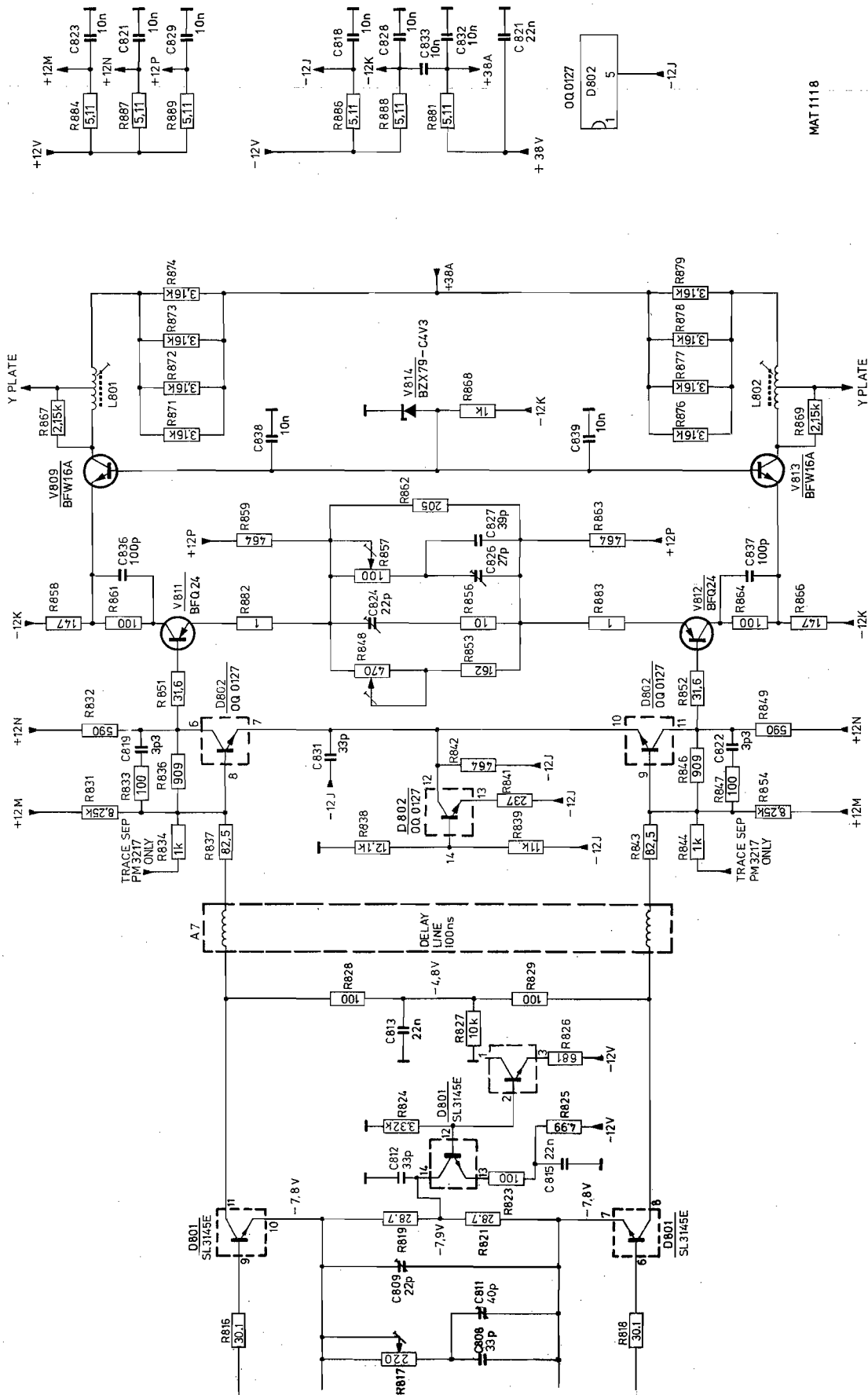

Fig. 2. Print lay out of the changed original amplifier.



MAT1118

Fig. 3. Circuit diagram final amplifier and changes of original diagram.

Positive feedback

Now you are the user of a Philips test and measuring instrument. We trust that it will give you many years of faithful service. But we would like you to realize one thing: we can only supply the best in T & M equipment with **your** help, user.

We need to know what you have found to be the strong and weak points of this instrument; and we would be very interested to hear about any unusual or elegant applications you have devised for it. Some of this information can be passed on to our design and development departments; and some may be fed back to other users via our bimonthly publication **T & M News**.

May we therefore suggest that you fill in the reply card alongside and send it back to us right now. That way, you'll be helping to provide the positive feedback we need to help you!

All contributions that are published will be paid for at current rates; while as an inducement for you to fill in the reply card, we are offering a free subscription to T & M News or a free copy of Part I of our Digital Instrument Course to all who reply.

Erfahrungsaustausch

Meßgeräte müssen sich in der Praxis bewähren und die in sie gesteckten Erwartungen erfüllen; auch bei Ihnen, dem Besitzer eines Geräts aus der Serie der Philips Test- und Meßgeräte. Wir aber können T & M-Geräte nur zu Ihrer vollen Zufriedenheit herstellen, wenn wir alle Ihre Wünsche kennen.

Deshalb interessiert uns Ihre Meinung über die guten und weniger guten Eigenschaften dieses Gerätes. Außerdem suchen wir Erfahrungen über ungewöhnliche oder neue Anwendungsmöglichkeiten. Vielleicht können Sie unseren Entwicklungs- und Konstruktionsabteilungen einen guten Wink geben; vielleicht können wir Ihre Erfahrungen aber auch in unserer Publikation **Info-dienst** (nur in Deutschland) veröffentlichten, damit auch andere Anwender davon profitieren können.

Deshalb möchten wir Sie bitten, die anhängende Antwortkarte auszufüllen und an uns zurückzusenden. Damit helfen Sie uns, und wir können Ihnen helfen!

Alle veröffentlichten Beiträge werden dem üblichen Tarif entsprechend honoriert. Als Dank für das Ausfüllen der Antwortkarte bieten wir Ihnen ein Freiabonnenment auf Info-dienst (nur in Deutschland) oder ein kostenloses Exemplar von Teil I von unserem Kursus Digital Instrument.

L'intérêt du "feedback"

Vous voilà possesseur d'un instrument d'essai et de mesure Philips. Nous espérons qu'il vous donnera de nombreuses années de bons et loyaux services, mais nous voudrions attirer votre attention sur un point: c'est qu'avec **votre** aide que nous pouvons fournir des matériels d'essai et de mesure de toute première qualité.

Nous avons besoin de savoir quels en sont les points forts et les points faibles que vous avez découverts et nous serions très intéressés d'apprendre quelles applications inhabituelles ou élégantes vous lui avez trouvés. Certains de ces renseignements peuvent être transmis utilement à nos bureaux d'études; certains autres peuvent être communiqués à d'autres utilisateurs par l'intermédiaire de notre publication **T & M Informations** (édition française seulement en France).

C'est pourquoi nous vous serions reconnaissants de remplir la carte-réponse à côté et de nous la renvoyer. De cette façon, vous contribuerez à nous fournir le "feedback" dont nous avons besoin pour mieux vous servir!

Toutes les réponses publiées seront payées conformément aux tarifs en vigueur; pour vous inciter à remplir la carte-réponse, nous offrons un abonnement gratuit à T & M Informations ou un exemplaire gratuit de la première partie de notre cours sur les instruments numériques à tous ceux qui répondront.

Details of user: **Persönliche Angaben:** **Expéditeur:**
Company/
Firma/Société
Department/
Abteilung/Service
Street/Straße/Rue
Box/Postfach/Boîte Postale
City/Stadt/Ville
Country/Land/Pays
Name/Name/Nom
Phone/Telefon/Numéro de téléphone

Details of instruments: **Gerätedaten:** **Instrument:**
Name/Name/
Désignation
Type number/Typennummer/
Numéro de type
Serial number/Seriennummer/
Numéro de série
Date purchased/Kaufdatum/
Date d'achat

What are the main applications for which you use this instrument?
Wofür verwenden Sie dieses Gerät hauptsächlich?
Quelles sont les principales utilisations auxquelles vous affectez
cet instrument?
.....
.....

Please, list what you consider to be the **strong points** and the **weak points** of the instrument. Zählen Sie bitte auf, was Ihrer Meinung nach die **guten Seiten** und was die **schwachen Stellen** dieses Geräts sind. Veuillez énumérer ce que vous considérez être les **points forts** et les **points faibles** de l'instrument.
.....
.....

Do you have any queries about the use of this instrument? If so, what?
Haben Sie irgendwelche Fragen über die Anwendung dieses Geräts? Wenn ja, welche?
Avez-vous des questions à poser sur l'emploi de l'instrument?
Si oui, lesquelles?
.....
.....

I have devised an interesting application for this instrument.
 I enclose a brief description (up to about 500 words) of this application
 Please send a representative to collect information about the application

Ich habe einen interessanten Verwendungszweck für dieses Gerät gefunden.
 Eine kurze Beschreibung hiervon (max. ca. 500 Wörter) erhalten Sie anliegend.
 Senden Sie bitte jemanden, der sich an Ort und Stelle über den Verwendungszweck informieren kann.

J'ai trouvé une application intéressante pour cet instrument
 Je joins une brève description (500 mots environ au maximum) de cette application.
 Veuillez envoyer un représentant à qui nous donnerons des renseignements sur l'application.

I would like to receive **T & M News** regularly.
 Please send me Digital Instrument Course Part I.
 Ich möchte **Info-dienst** regelmäßig beziehen.
 Senden Sie mir Digital Instrument Course, Teil I.
 J'aimerais recevoir **T & M Informations** régulièrement.
 Envoyez moi la première partie du cours sur les instruments numériques.



PHILIPS

T & M News
 N.V. PHILIPS' GLOEILAMPENFABRIEKEN
 S & I TQ III - 4
 Test and Measuring Instruments Department
 Att. Mr. T. Sudar
 EINDHOVEN
 The Netherlands

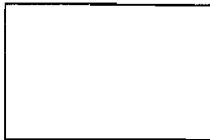

please fold

T & M News is your feedback unit

T & M News is a bimonthly publication issued by the T & M Measuring Department of Philips' Science & Industry Division, for distribution to actual and potential users of Philips' T & M equipment. It provides an effective means of exchanging information in the T & M field - both from the manufacturer to the customer and vice versa.

Apart from T & M News itself, we also issue T & M Reports, which provide a vehicle for (generally longer) articles of a more specialized and/or theoretical nature to supplement the information given in T & M News. These Reports, being of a more specialized interest, are generally sent to a more restricted group of users; though anyone who is interested can obtain them on request.

One special series that was brought out in supplements to T & M News is our Digital Instrument Course (Part I: Basic binary theory and logic circuits; Part II: Digital counters and timers; Part III: Digital voltmeters and multimeters; Part IV: IEC Bus Interface), which proved so popular with readers that each part of the course has been issued in booklet form.

Info-dienst für Ihren Erfahrungsaustausch

Info-dienst (nur in Deutschland) ist eine Publikation der Philips GmbH Unternehmensbereich für Elektronik für Wissenschaft und Industrie für die jetzigen Besitzer und potentiellen Kunden von Philips T & M-Geräten. Dieses Blatt strebt einen effektiven Informationsaustausch auf dem T & M-Gebiet zwischen Hersteller und Anwender sowie umgekehrt an.

Neben diesen Info-dienst geben wir auch die T & M Reports heraus (nur in englischer Sprache), in denen (im allgemeinen längere) Artikel mehr spezieller bzw. theoretischer Art als Ergänzung zu den Informationen in Info-dienst stehen. Diese Reports, an denen in allgemeinen nur Spezialisten interessiert sind, werden an eine begrenzte Anwendergruppe verteilt. Jeder, der daran interessiert ist, kann sie auf Anfrage erhalten.

Eine spezielle Serie, die gerade in den T & M News Supplements erschienen ist, war unser Digital Instrument Course (Teil I: Basic binary theory and logic circuits; Teil II: Digital counters and timers; Teil III: Digital voltmeters and multimeters; Teil IV: IEC Bus Interface). Diese Serie war bei den Lesern so populär, daß jeder Teil von diesem Kursus auch in Buchform herausgegeben wurde (nur in englischer Sprache).

T & M Informations est notre moyen de communiquer mutuellement

T & M Informations est une publication de département de Mesure de Philips, destinée aux utilisateurs effectifs et un puissance d'appareils d'essai et de mesure Philips. Elle constitue un moyen efficace de transmettre de l'information dans ce domaine, aussi bien du fabricant vers le client que vice versa.

A part la publication T & M Informations proprement dite, nous diffusons les T & M Reports (seulement en anglais) qui contiennent des articles (généralement plus longs) de nature plus spécialisée ou plus théorique, destinés à compléter l'information donnée dans T & M Informations. Etant donné leur nature, ces Reports ne sont généralement envoyés qu'à un cercle plus restreint d'utilisateurs; toutefois, quiconque s'y intéresse peut les obtenir sur demande.

Nous venons de publier dans les T & M News Supplements une série spéciale d'articles qui constituent un cours sur les instruments numériques (1ère partie: Théorie binaire de base et circuits logiques; 2ème partie: Compteurs numériques et minuteries; 3ème partie: voltmètres et multimètres numériques; 4ème partie: IEC Bus Interface) qui a rencontré un tel succès auprès des lecteurs que chaque partie du cours a été réimprimée sous forme de livret (seulement en anglais).



Dual Channel Oscilloscope PM3217B - PM3217BU

Supplement to operating manual and service manual PM3217
Ergänzung zur Gebrauchsanleitung und Service Handbuch PM3217
Supplément à la notice d'emploi et d'entretien PM3217

9499 443 02801
820224

Attention: This manual is also suitable for PM3214B and PM3218B.



PHILIPS

IMPORTANT

In correspondence concerning this instrument, please quote the type number and serial number as given on the type plate.

NOTE: *The design of this instrument is subject to continuous development and improvement. Consequently, this instrument may incorporate minor changes in detail from the information contained in this manual.*

WICHTIG

Bei Schriftwechsel über dieses Gerät wird gebeten, die genaue Typenbezeichnung und die Gerätenummer anzugeben. Diese befinden sich auf dem Leistungsschild.

BEMERKUNG: *Die Konstruktion und Schaltung dieses Geräts wird ständig weiterentwickelt und verbessert. Deswegen kann dieses Gerät von den in dieser Anleitung stehenden Angaben abweichen.*

IMPORTANT**RECHANGE DES PIECES DETACHEES (Réparation)**

Dans votre correspondance et dans vos réclamations se rapportant à cet appareil, veuillez TOUJOURS indiquer le numéro de type et le numéro de série qui sont marqués sur la plaquette de caractéristiques.

REMARQUES: *Cet appareil est l'objet de développements et améliorations continuels. En conséquence, certains détails mineurs peuvent différer des informations données dans la présente notice d'emploi et d'entretien.*

CONTENTS

Page

1. GENERAL INFORMATION	1
1.1. Introduction	1
1.2. Characteristics	1
1.2.1. C.R.T.	1
1.2.2. Vertical or Y-axis	1
1.2.3. Horizontal or X-axis	1
1.2.4. Main time base	1
1.2.5. Delayed time base	1
1.2.6. X-deflection	2
1.2.7. Triggering of the MTB	2
1.2.8. Triggering of the DTB	2
1.2.9. Calibration generator	2
1.2.10. Power supply	2
1.2.11. Environmental characteristics	3
1.2.12. Mechanical data	3
1.3. Accessoires	3
1.3.1. Supplied with the instrument	3
2. INSTALLATION INSTRUCTIONS	4
2.1. Important safety instructions	4
2.2. Installation	4
3. SERVICE MANUAL	14

INHALT

1. ALLGEMEINES	5
1.1. Einleitung	5
1.2. Technische Daten	5
1.2.1. Elektronenstrahlröhre	5
1.2.2. Vertikal oder Y-Achse	5
1.2.3. Horizontal oder X-Achse	5
1.2.4. Hauptzeitablenkung	5
1.2.5. Verzögerte Zeitablenkung	5
1.2.6. X-Ablenkung	6
1.2.7. Triggerung der Hauptzeitablenkung	6
1.2.8. Triggerung der verzögerte Zeitablenkung	6
1.2.9. Kalibriergenerator	6
1.2.10. Stromversorgung	6
1.2.11. Einflussgrößen	7
1.2.12. Mechanische Daten	7
1.3. Zubehör	7
1.3.1. Mitgeliefert	7

2. VORBEREITUNGSANWEISUNGEN	8
2.1. Wichtige sicherheitstechnische Hinweise	8
2.2. Installierung	8
3. SERVICE MANUAL (nur aufs English)	14

TABLE DES MATIERES

1. GÉNÉRALITÉS	9
1.1. Introduction	9
1.2. Caractéristiques	9
1.2.1. Tube cathodique	9
1.2.2. Axe vertical ou Y	9
1.2.3. Axe Y ou horizontal	9
1.2.4. Base de temps principale	9
1.2.5. Base de temps retardée	9
1.2.6. Deviation X	10
1.2.7. Déclenchement de la base de temps principale	10
1.2.8. Déclenchement de la base de temps retardée	10
1.2.9. Générateur d'étalonnage	10
1.2.10. Alimentation	10
1.2.11. Conditions ambiantes	11
1.2.12. Caractéristiques mécaniques	11
1.3. Accessoires	11
1.3.1. Fournis avec l'instrument	11
2. INSTALLATION	12
2.1. Règlements de sécurité	12
2.2. Installation	12
3. SERVICE MANUAL (seulement en Anglais)	14

1. GENERAL INFORMATION

This supplement contains additional and substitutive information for the operating manual as well as for the service manual of the PM 3217.

1.1. INTRODUCTION

The battery model oscilloscope is identical to the standard model, with the exception of the built-in battery supply.

This portable version can be used for at least 2½ hours on batteries and has facilities for recharging the batteries in two different ways, namely, a trickle-charge mode and a fast-charge mode.

A trickle charge is given automatically to the batteries when the instrument is connected to the mains supply and switched on.

A fast charge is given automatically to the batteries when the instrument is connected to the mains supply but is switched off. In this mode, the POWER-ON pilot lamp serves to indicate the state of the batteries. If the batteries are under charge with the maximum current of 300 mA, the pilot lamp flashes once per 2 ... 5 seconds.

On completion of the charge, i.e. when the batteries are fully charged, the pilot lamp is momentarily extinguished once every three seconds. Under all other working conditions of the instrument, the pilot lamp blinks continuously.

The internal batteries are fully protected against over-charging when the instrument is left in the charge position for a prolonged time period.

Similarly, at the other extreme, the internal batteries are protected against excessive discharge. At the same time, this prevents the oscilloscope being used on too low a battery supply (low limit approximately 22.3 V), thus avoiding measuring errors.

The instrument can still be operated on an external battery supply of 22 V to 27 V.

1.2. CHARACTERISTICS

Only the additional or different data with respect to the basic instrument are given.

1.2.1. C.R.T.

– Unchanged

1.2.2. Vertical

Add: — Capacitance from cabinet to earth (when powered from internal battery)

185 pF with rubber feet standing on an earthed metal plate of not less than 1 m²

27 pF with oscilloscope 30 cm above an earthed metal plate of not less than 1 m²

1.2.3. Horizontal

– Unchanged

1.2.4. Main time base

– Unchanged

1.2.5. Delayed time base

– Unchanged

1.2.6. X Deflection

- Unchanged

1.2.7. Triggering of the main time base

- Unchanged

1.2.8. Triggering of the delayed time base

- Unchanged

1.2.9. Calibration generator

- Unchanged

1.2.10. Power supply

- Source available a.c. mains supply
external battery supply
internal battery supply

1.2.10.1. Power from mains

AC supply		
Nominal voltage range	110, 127, 220, 240 V a.c.	± 10 %
Nominal frequency range	50 ... 400 Hz ± 10 %	
Power consumption	29.5 W max.	At nominal line voltage

1.2.10.2. Power from external battery

Battery supply		
Voltage range	22 V to 27 V d.c.	Battery minus (–) connected to chassis
Current consumption	1.1 A max.	

1.2.10.3. Power from internal battery

Operating period with fully charged battery (scale illumination dimmed)

- continuous service 2½ hours
- intermittent service 2¾ hours
- duty cycle 50 %, max. ON-time 30 min.

The internal battery is switched off automatically if the voltage drops below 22.3 V to prevent excessive discharge and faulty operation of the oscilloscope by insufficient supply voltage.

Fast-charge of internal battery

- charging period 10 hours approx. from fully discharged state
- power consumption 17 W max. at nominal line voltage
- charging rate 0.3 A max. at nominal line voltage
- charge indication POWER ON pilot LED blinks once per second
- end-of-charge indication POWER ON pilot LED momentarily extinguishes once every 2 ... 5 seconds

There is no facility to charge the internal battery from the external d.c. supply, or to charge the external battery through the oscilloscope charger from the mains supply.

Internal battery details:

- type Sonnenschein 4GX 3S or equivalent
- number 3
- rating 8 V at 3 Ah

1.2.11. Environmental characteristics

The characteristics are valid only if the instrument is checked in accordance with the official checking procedures. Details on these procedures and failure criteria are supplied on request by the PHILIPS organisation in your country, or by N.V. PHILIPS' GLOEILAMPENFABRIEKEN, TEST AND MEASURING DEPARTMENT, EINDHOVEN, THE NETHERLANDS.

Ambient temperature:

Internal batteries removed

– rated range of use	+ 5 °C ... +40 °C
– limited range of use	–10 °C ... +55 °C
– storage and transit	–40 °C ... +70 °C

Internal batteries installed

– rated range of use	+ 5 °C ... +35 °C	
– limit range of use	–10 °C ... +35 °C	when mains powered
	–10 °C ... +40 °C	when battery powered
	–10 °C ... +45 °C	when on fast-charge
– storage and transit	–25 °C ... +50 °C	

Humidity

According to IEC 68 Db

Vibration

30 minutes in each of three directions, 10 ... 150 Hz;
0.7 mm p-p and 5 g max. acceleration

Bump

1000 Bumps of 10 g, ½ sine 6 ms duration in each of 3 directions

Altitude:

– operating	5000 m (475 mbar = 47.5 K Pa)
– not operating	15000 m (100 mbar = 10 K Pa)

Recovery time

30 minutes when instrument is subjected to temperature rise from –10 °C to 20 °C at 60 % relative humidity

EMI

Storgrad "K" VDE

1.2.12. Mechanical data

- Unchanged

1.3. ACCESSORIES

1.3.1. Supplied with the instrument

- Unchanged

2. INSTALLATION INSTRUCTIONS

2.1. IMPORTANT SAFETY INSTRUCTIONS (IN ACCORDANCE WITH IEC 348)

Before connecting the instrument to the mains (line), visually check the cabinet, controls and connectors, etc., to ascertain whether any damage has occurred in transit. If any defects are apparent, do not connect the instrument to the mains (line).

CLAIMS

In the event of obvious damage or shortages, or if the safety of the instrument is suspect, a claim should be filed with the carrier immediately. A Philips Sales or Service organisation should also be notified in order to facilitate repair of the instrument.

The instrument must be disconnected from all voltage sources and any high voltage points discharged before any maintenance or repair work is carried out.

If adjustments or maintenance of the operating instrument with covers removed is inevitable, it must be carried out only by a qualified person who is aware of the hazards involved.

2.2. INSTALLATION

Power source selection

TABLE OF CONDITIONS

<i>Mains plug connected to mains (Line)</i>	<i>External battery connected to rear socket</i>	<i>Power switch On or Off</i>	<i>Result</i>
Yes	No	On	Oscilloscope powered from mains. Internal battery trickle-charged at 30 mA maximum.
No	No	On	Oscilloscope powered from internal battery
Yes	—	Off	Internal battery on fast charge of 300 mA maximum.
No	Yes	On	Oscilloscope powered from external battery.
Yes	Yes	On	Oscilloscope powered from mains or from external battery depending on voltage level. Internal battery trickle-charged at 30 mA maximum.
No	—	Off	Instrument switched off and batteries disconnected.

1. ALLGEMEINES

Diese Ergänzung enthält zusätzliche und ergänzende Einzelheiten der PM 3217 Gebrauchsanleitung und des Service Handbuchs.

1.1. EINLEITUNG

Das Batterieversion Oszilloskop und die Standardversion sind mit Ausnahme der eingebauten Batteriespeisung völlig identisch.

Diese tragbare Ausführung kann mindestens 2½ Stunden mit Batterien betrieben werden und umfasst eine Einrichtung zum Wiederaufladen der Batterien auf zweierlei Weise, nämlich Pufferladung und Schnellladung. Eine Pufferladung der Batterien erfolgt automatisch sobald das Gerät an das Netz angeschlossen und eingeschaltet wird.

Ein Schnellladung der Batterien erfolgt automatisch wenn das Gerät an das Netz angeschlossen und ausgeschaltet ist. Bei dieser Ladeweise dient die POWER ON Signallampe zur Anzeige des Zustands der Batterien. Wenn die Batterien mit dem Maximalstrom von 300 mA geladen werden dann leuchtet die Signallampe einmal pro Sekunde auf. Nach Beendigung der Ladung, d.h. wenn die Batterien völlig aufgeladen sind, dann erlischt die Signallampe kurzzeitig alle 2 bis 5 Sekunden. Unter allen anderen Betriebsbedingungen des Geräts längere Zeit in andauernd.

Die internen Batterien sind voll geschützt gegen Überladung wenn das Gerät längere Zeit in Ladezustand gelassen wird.

Im entgegengesetzten Fall sind die Batterien gleichermassen gegen übermässige Entladung geschützt. Zugleich wird dadurch verhindert dass das Oszilloskop an zu niedriger Batteriespeisung betrieben wird (unterer Grenzwert etwa 22,3 V), wodurch sich Messfehler vermeiden lassen.

Betrieb des Gerät mit externer Batteriespeisung von 22 V bis 27 V ist ebenfalls möglich.

1.2. TECHNISCHE DATEN

Es sind nur diejenigen Daten aufgeführt, die von denen des Grundinstruments abweichen oder zusätzlich aufgenommen werden.

1.2.1. Elektronenstrahlröhre

– Unverändert

1.2.2. Vertikale oder Y-Achse

Zufügen: – Kapazität von Gehäuse gegen Erde (bei Speisung von interner Batterie)	185 pF	mit Gummifüssen auf einer geerdeten Metallplatte nicht kleiner als 1 m ² stehend.
	27 pF	mit dem Oszilloskop 30 cm über einer geerdeten Metallplatte nicht kleiner als 1 m ² .

1.2.3. Horizontale oder X-Achse

– Unverändert.

1.2.4. Hauptzeitablenkung

– Unverändert.

1.2.5. Verzögerte Zeitablenkung

– Unverändert.

1.2.6. X-Ablenkung

- Unverändert.

1.2.7. Triggerung der Hauptzeitablenkung

- Unverändert.

1.2.8. Triggerung der verzögerten Zeitablenkung

- Unverändert.

1.2.9. Kalibriergenerator

- Unverändert.

1.2.10. Versorgung

- Vorhandene Quellen Aus einem AC Netz
Externe Batteriespeisung
Interne Batteriespeisung

1.2.10.1. Stromversorgung vom Netz

AC-Speisung		
Nennspannungsbereich	110, 127, 220, 240 AC \pm 10 %	
Nennfrequenzbereich	50 ... 400 Hz \pm 10 %	
Leistungsaufnahme	29.5 W max.	Bei Netznennspannung

1.2.10.2. Versorgung mit externer Batterie

Spannungsbereich	22 V bis 27 V DC	Batterie minus (–) verbünden mit dem Chassis
Stromaufnahme	1.1 A max.	

1.2.10.3. Versorgung mit interner Batterie

Betriebszeit mit voll geladener Batterie (Skalenbeleuchtung gedämpft)

- Ununterbrochener Betrieb 2½ Stunden
 - Unterbrochener Betrieb 2¼ Stunden
- bei einem Zyklus von 30 Minuten "AN" und minimal 30 Minuten "AUS".

Sobald die Spannung unter 22,3 V abfällt wird die interne Batterie automatisch abgeschaltet um übermäßige Entladung und somit fehlerhaften Betrieb des Oszilloskops durch ungenügende Speisespannung zu verhindern.

Schnellladung der internen Batterie

- Ladedauer etwa 10 Stunden, von gänzlich entladem Zustand
- Leistungsaufnahme 17 W max. bei Netznennspannung
- Ladestrom 0,3 A max. bei Netznennspannung
- Ladungsanzeige Signal LED "POWER ON" blinkt einmal pro Sek.
- Ladungsende Anzeige Signal LED "POWER ON" leuchtet und erlischt nach jeweils 2 bis 5 Sek.

Ladung der internen Batterie über die externe Gleichspannung oder Ladung der externen Batterie über die Netzspannung ist nicht möglich.

Interne Batterie Daten

- Type Sonnenschein 4GX 3S oder gleichwertig
- Anzahl 3
- Kapazität 8 V bei 3 Ah

1.2.11. Einflussgrößen

Die angegebenen Daten gelten nur, wenn das Gerät gemäss dem offiziellen Prüfverfahren kontrolliert wird. Einzelheiten betreffend diese Verfahren sowie Funktionsstörungen-Kriterien sind auf Anfrage bei der Philips-Organisation Ihres Landes oder bei N.V. PHILIPS' GLOEILAMPENFABRIEKEN, ABTEILUNG TEST-UND MESSGERÄTE, EINDHOVEN, NIEDERLANDE, erhältlich.

Umgebungstemperatur:

Interne Batterien entfernt

Nominaler Betriebsbereich	+5 °C ... +40 °C
Zugelassener Betriebstemperaturbereich	-10 °C ... +55 °C
Lagerung und Transport	-40 °C ... +70 °C

Interne Batterien eingebaut

Nominaler Betriebsbereich	+5 °C ... +35 °C	
Höchstzulässiger Betriebsbereich	-10 °C ... +35 °C	Bei Netzspannung
	-10 °C ... +40 °C	Bei Batteriespeisung
	-10 °C ... +45 °C	Bei Schnellladung
Lagerung und Transport	-25 °C ... +50 °C	

Luftfeuchte	Entspricht den IEC 68 dB Bedingungen.	
Stossfestigkeit	1000 Stösse je 10g ½ Sinus, Dauer 6 ms in jeder der 3 Richtungen	
Vibration	30 Minutes in jeder der 3 Richtungen, 10 - 150 Hz; 0,7 mm Spitze-Spitze und 5 g	
Höhe		
– Betriebsfähig	5000 m (475 mbar = 47,5 KPa)	
– Nicht betriebsfähig	15000 m (100 mbar = 10 KPa)	
Erholungszeit	30 Minuten wenn die Temperatur des Gerätes von -10 °C auf +20 °C erhöht wird, bei 60 % relativer Luftfeuchtigkeit.	
Funkstörungen	Störgrad "K" VDE	

1.2.12. Mechanische Daten

– Unverändert.

1.3. ZUBEHÖR

1.3.1. Mitgeliefert

– Unverändert.

2. VORBEREITUNGS ANWEISUNGEN

2.1. WICHTIGE SICHERHEITSTECHNISCHE HINWEISE (den IEC 348 Bedingungen entsprechend)

Vor Anschluss des Geräts ist eine Sichtkontrolle vorzunehmen, um festzustellen, ob das Gerät möglicherweise während des Transports beschädigt wurde. Wenn irgend welche Defekte wahrgenommen werden, darf das Gerät nicht an das Netz angeschlossen werden.

REKLAMATIONEN:

Im Fall offensichtlicher Beschädigungen oder Mängel oder wenn der sicherheitstechnische Zustand zweifelhaft erscheint, muss beim Überbringer sofort reklamiert werden. Eine Philips Verkaufs- oder Servicestelle muss ebenfalls verständigt werden um Reparatur des Geräts zu ermöglichen.

Vor Wartungs- oder Reparaturarbeiten ist das Gerät von allen Stromquellen zu trennen, und alle Hochspannung führende Teile müssen entladen sein. Wenn danach eine Kalibrierung, Wartung oder Reparatur am geöffneten Gerät unter Spannung unvermeidlich ist, so darf das nur durch eine Fachkraft, die die damit verbundenen Gefahren kennt, geschehen.

2.2. INSTALLIERUNG

Wahl der Stromquelle

BEDINGUNGEN

<i>Steckerverbindung mit Netz</i>	<i>Externe Batterie mit Buchse an der Rückwand verbunden</i>	<i>Netzschalter ON oder OFF</i>	<i>Ergebnis</i>
Ja	Nein	On	Oszilloskop von Netz gespeist. Interne Batterie Pufferladung, 30 mA max.
Nein	Nein	On	Oszilloskop von interner Batterie gespeist.
Ja	—	Off	Interne Batterie Schnellladung, 300 mA max.
Nein	Ja	On	Oszilloskop von externer Batterie gespeist.
Ja	Ja	On	Oszilloskop, je nach Spannungspegel, von Netz oder von externer Batterie gespeist. Interne Batterie Pufferladung, 30 mA max.
Nein	—	Off	Oszilloskop aus- und interne Batterie abgeschaltet.

1. GENERALITES

La présente supplément contient données complémentaires et remplaçantes à la notice d'emploi et d'entretien PM 3217.

1.1. INTRODUCTION

L'oscilloscope du type alimentation par batteries est identique aux version standard à exception de l'alimentation par batteries incorporée. Cette version portative peut être utilisée pendant au moins 2½ heures; de plus, il est possible de recharges les batteries de deux façon différentes, en mode de charge permanente et en mode de charge rapide.

La charge permanente s'obtient automatiquement en branchant l'appareil au secteur et en le mettant en circuit.

La charge rapide s'obtient automatiquement en branchant l'appareil au secteur sans le mettre en circuit. Dans ce mode, le témoin POWER ON sert à indiquer la condition des batteries. Si les batteries sont chargées par le courant maximal de 300 mA, le témoin clignote une fois par seconde. Lorsque les batteries sont chargées au maximum, le témoin s'éteint toutes les 2 à 5 secondes. Dans toutes autres conditions de travail, le témoin est continûment allumé.

Les batteries internes sont entièrement protégées contre la surcharge au cas où l'appareil est rechargé pendant une période prolongé.

De même, les batteries interne sont protégées contre une décharge excessive. L'oscilloscope ne peut donc pas être utilisé à trop faible alimentation par batteries (limite inférieure environ 22,3 V), ce que évite les erreurs de mesure.

L'appareil peut aussi être utilisé sur alimentation batterie externe de 22 V à 27 V.

1.2. CARACTERISTIQUES

Seules les données différentes ou présentant un caractère supplémentaire, ceci par rapport à la version de base sont mentionnées ici.

1.2.1. Tube cathodique

– Inchangé.

1.2.2. Axe vertical ou Y

A ajouter: — capacité du coffret à la terre
(en cas d'alimentation par batteries)

185 pF avec pieds de caoutchouc sur plaque
métallique mise à la terre d'une surface
d'au moins 1 m²

27 pF oscilloscope 30 cm au-dessus d'une plaque
métallique mise à la terre d'une surface
d'au moins 1 m².

1.2.3. Axe X ou horizontal

– Inchangé.

1.2.4. Base de temps principale

– Inchangé.

1.2.5. Base de temps retardée

– Inchangé.

1.2.6. Déviation X

- Inchangé.

1.2.7. Déclenchement de la base de temps principale

- Inchangé.

1.2.8. Déclenchement de la base de temps retardée

- Inchangé.

1.2.9. Générateur d'étalonnage

- Inchangé.

1.2.10. Alimentation

- Source disponibles alimentation secteur en alternatif
 alimentation externe par batteries
 alimentation interne par batteries

1.2.10.1. Alimentation secteur

En alternatif

Gamme de tension nominale	110, 127, 220, 240 V alternatif $\pm 10\%$	
Gamme de fréquence nominale	50 ... 400 Hz $\pm 10\%$	
Consommation	29.5 W	pour tension secteur nominale

1.2.10.2. Alimentation externe par batteries

Gamme de tension	22 V à 27 V continu	Negative (–) de batterie assemblé avec chassis
Consommation de courant	1,1 A maxi.	

1.2.10.3. Alimentation interne par batteries

Période de fonctionnement avec batteries entièrement chargées (éclairage d'échelle sur minimum)

- fonctionnement continu 2½ heures
- fonctionnement intermittent 2¾ heures

Ceci vaut pour cycle de 30 min. en service max. et un minimum de 30 min. hors service.

La batterie interne est automatiquement mise hors circuit dès que la tension est inférieure à 22,3 V, et ce pour éviter la décharge excessive et le fonctionnement incorrect de l'oscilloscope par alimentation insuffisante.

Recharge rapide de la batterie interne

- période de charge 10 heures environ en partant de la condition déchargée
- consommation 17 W max. à tension secteur nominale
- taux de charge 0,3 A max. à tension secteur nominale
- indication de charge le témoin LED "POWER ON" clignote une fois par seconde
- indication charge totale le témoin LED "POWER ON" est allumé et s'éteint toutes les 2 à 5 secondes.

Il n'est pas possible de charger la batterie interne à partir d'une source continue externe ou de charger la batterie externe par le chargeur de l'oscilloscope via le secteur.

Caractéristiques de batterie interne

- type Sonnenschein 4GX 3S ou équivalent
- nombre 3
- capacité 8 V à 3 Ah

1.2.11. Conditions ambiantes

Les données relatives aux conditions ambiantes ne sont valables que si l'instrument est contrôlé conformément aux méthodes officielles. Des renseignements sur ces méthodes et sur les critères employés sont fournis sur demande par l'organisation Philips de votre pays ou par le TEST AND MEASURING DEPARTMENT de la N.V. PHILIPS' GLOEILAMPENFABRIEKEN à EINDHOVEN, PAYS-BAS.

Température ambiante:

Sans batteries internes

- gamme de référence d'utilisation + 5 °C ... +40 °C
- gamme limite d'utilisation –10 °C ... +55 °C
- conditions de stockage et de transport –40 °C ... +70 °C

Avec batteries internes

- gamme de référence d'utilisation + 5 °C ... +35 °C
- gamme limite d'utilisation –10 °C ... +35 °C par secteur
- 10 °C ... +40 °C par batterie
- 10 °C ... +45 °C par charge rapide
- conditions de stockage et de transport –25 °C ... +50 °C

Humidité	Suivant IEC 68 Db
Essais de vibration	30 minutes dans chacune des 3 directions; 10-150 Hz; amplitude 0.7 mm c.c. et 5 g
Chocs	1000 chocs de 10 g, ½ sinus d'une durée de 6 ms dans chacune des 3 directions
Altitude maximum:	
– en fonctionnement	5000 m (475 m bars = 47,5 KPa)
– hors fonctionnement	15000 m (100 m bars = 10 KPa)
Temps de rétablissement	30 minutes si la température l'instrument passe de –10 °C à +20 °C sous humidité relative de 60 %
EMI	Störgrad "K" VDE

1.2.12. Caractéristiques mécaniques

- Inchangé.

1.3. ACCESSOIRES

1.3.1. Fournis avec l'instrument

- Inchangé.

2. INSTALLATION

2.1. REGLEMENTS DE SECURITE (conformes à la CEI 348 premier édition)

Avant de brancher l'instrument sur le secteur, examiner le boîtier, les commandes, les connecteurs, etc. afin de s'assurer qu'il n'y a pas eu de dommages en cours de transport. En cas de défauts, ne pas brancher l'instrument.

RECLAMATIONS

En cas de dommages ou d'insuffisances, ou si la sécurité de l'appareil est mise en doute, une réclamation doit être adressée directement au transporteur. De plus, il faudra également avertir une organisation de vente ou de service Philips afin de faciliter le procédé de réparation.

Il faut déconnecter l'instrument de toute source de tension et décharger les points sous tension avant d'effectuer un travail d'entretien ou de réparation. Si les réglages ou l'entretien ne peuvent se faire que l'instrument en fonctionnement, couvercles déposés, le travail sera confié à un spécialiste, conscient des risques encourus.

2.2. INSTALLATION

Sélection de source d'alimentation

CONDITIONS

<i>Fiche secteur branché au secteur (réseau)</i>	<i>Batterie externe connectée à la douille arrière</i>	<i>Interrupteur marche/arrêt</i>	<i>Résultat</i>
Oui	Non	marche	Oscilloscope alimenté par secteur. Batterie interne en charge permanente à 30 mA max.
Non	Non	marche	Oscilloscope alimenté par batterie interne
Oui	—	arrêt	Batterie interne sur charge rapide de 300 mA max.
Non	Qui	marche	Oscilloscope alimenté par batterie externe.
Oui	Oui	arrêt	Oscilloscope alimenté par secteur ou batterie externe en fonction du niveau de tension. Batterie interne sur charge permanente à 30 mA max.
Non	—	arrêt	Oscilloscope hors service et batterie déconnectée

WARNING!

THESE SERVICING INSTRUCTIONS ARE FOR USE BY QUALIFIED PERSONAL ONLY. TO AVOID ELECTRIC SHOCK, DO NOT PERFORM ANY SERVICING OTHER THAN THAT CONTAINED IN THE OPERATING INSTRUCTIONS UNLESS YOU ARE QUALIFIED TO DO SO.

Service manual

CONTENTS

Page

3. SERVICE MANUAL	15
3.1. Block diagram description of the battery supply unit	15
3.1.1. Fast charge mode	15
3.1.2. Trickle charge mode	15
3.1.3. Mains operation	15
3.1.4. Battery operation	15
3.2. Circuit description	16
3.2.1. Fast charge mode	16
3.2.2. Trickle charge mode	16
3.2.3. Mains operation	17
3.2.4. Battery operation	17
3.2.5. External battery supply	17
3.3. Checking and adjusting the internal battery control circuit	17
3.3.1. General information	17
3.3.2. Lo-LIM cut-out circuit	18
3.3.3. Hi-LIM cut-out circuit	18
3.3.4. Blinking frequency of the pilot lamp indicating the state of the battery charge	19
3.3.5. Final check	19
3.4. Battery information	19
3.4.1. Charging and discharging curves	19
3.4.2. Defective battery	19
3.5. Parts List	21
3.6. Circuit diagrams	24

3. SERVICE MANUAL

3.1. BLOCK DIAGRAM DESCRIPTION OF THE BATTERY SUPPLY UNIT (fig. 2)

3.1.1. Fast charge mode

When the instrument is connected to the mains and switch POWER ON is in position OFF, the RELAY CIRCUIT K1701 is energised.

The internal batteries are connected via the RELAY CIRCUIT K1701 contact to the HI-LIM CUT-OUT circuit (D1704). This circuit compares the battery level with a reference voltage to monitor the state of the battery.

If the battery level exceeds the reference; i.e. the battery is fully charged, the HI-LIM CUT-OUT circuit gives a high positive output. In this state, electronic switches V1722 and V1723 are cut off and the FAST CHARGE and TRICKLE CHARGE circuits are disconnected.

If the battery level is lower than the reference; i.e. the battery requires charging, the HI-LIM CUT-OUT circuit gives a low positive output. This causes the electronic switches V1722 and V1723 to open and the FAST CHARGE and TRICKLE CHARGE circuits are connected. This is the normal circuit operation for fast charging.

A signal output from the HI-LIM CUT-OUT circuit is also routed to electronic switch V1742 which is permanently closed during the fast-charge condition. This permits the BISTABLE MULTIVIBRATOR to supply the RC-GENERATOR circuit with a 0.5 sec pulse which, via the TRANSFORMER-RECTIFIER circuit, flashes the POWER-ON LED once every second to denote fast-charging.

When the battery is fully charged, the HI-LIM CUT-OUT circuit output is high positive, and the charging circuits are disconnected by electronic switches V1722 and V1723. At the same time, electronic switch V1742 is conductive and the resulting asymmetrical switching of the BISTABLE MULTIVIBRATOR causes the RC-GENERATOR to generate for about 3 seconds and to switch off for 0.5 seconds.

3.1.2. Trickle charge mode

In this mode the instrument is also connected to the mains and switch POWER is in position ON. Since in this mode the emitter of transistor V217 from the power supply of the oscilloscope is connected to diode V1728, the electronic switch V1726 is non conducting and the FAST CHARGE circuit is not operated.

3.1.3. Mains operation

When the instrument is used on mains supply, RELAY CIRCUIT K1702 is not operated. In this case the contacts of relay K1702 are in rest-position. Now the oscilloscope is supplied by the +28 V connected via diode V1717 to the positive side of capacitor C208 (positive supply rail of the instrument's power supply).

3.1.4. Battery operation

When the instrument is used only on batteries and switch POWER is in position ON, RELAY CIRCUIT K1701 and RELAY CIRCUIT K1702 both energise. The contacts of K1702 feed the d.c. output from the batteries to +C208.

If the battery voltage decreases to approximately 22.3 V, the LO-LIM CUT-OUT circuit output becomes low positive and the RELAY CIRCUIT K1702 releases and the battery voltage is disconnected from the instrument. The instrument remains cut off and the battery only delivers a slight current to its control circuits. At approx. 18 V the RELAY CIRCUIT K1701 also drops out and the battery circuits are completely disconnected, thus safeguarding them against complete discharge. External battery connection is available via the contacts, which are in rest-position, of relay K1702.

3.2. CIRCUIT DESCRIPTION (Fig. 3)

When the instrument is plugged into the mains, transformer T1701 is directly connected and together with the bridge rectifier V1701 provides a d.c. voltage, the positive side of which is connected via L1701 to the internal batteries G1701-G1703. Dependent upon the position of the instrument POWER ON switch, two charging rates of internal batteries can be provided.

3.2.1. Fast charge mode

With the instrument connected to the mains and switch POWER ON not operated, relay K1701 is energised by the load voltage via conducting transistor V1706.

The internal batteries are connected, via the contact of K1701, to both a low-limit (LO-LIM) and a high-limit (HI-LIM) comparator circuit to ascertain their condition.

High-limit cut-out circuit

In the high-limit comparator circuit, amplifier D1704, the batteries are connected to input 3, via the HI-LIM cut-out control R1742. Input 2 serves as a temperature-controlled reference voltage, derived from zener diodes V1737, V1738, V1739 and V1741. So long as the battery voltage on input 3 is lower than the reference voltage on input 2, the output on pin 6 of D1704 is low positive, and charging OCCURS.

In this condition, switching transistors V1722 and V1723 become conductive due to this low positive voltage applied to their bases.

The fast charge circuit operates via V1722 and R1718. In the fast charge mode the trickle-charge circuit is included and charging also occurs via V1723 and R1719. The charging current is determined by the setting of the preset potentiometer R1731, which controls the input potential of pin 3 on amplifier D1702.

Charge indication circuit

As indication of charging is given by the POWER ON LED flashing once every second. The circuit operates as follows:

During charging, the low positive output on pin 6 of D1704 is also applied to block zener diode V1743, and the switching transistor V1742 is non-conductive. In this case, the +28 V collector of V1742 is applied via R1749 to the base of V1746, one side of a bistable multivibrator circuit (V1744/V1746), to provide an output signal with a symmetrical mark-space ratio.

The output pulses are taken from the emitter of V1746 to an RC-generator circuit. This comprises transistor V1748 with a three-stage RC feedback network between its collector and base. The transformer T1702 serves to isolate the circuit from the POWER ON LED, which is connected to the instrument cabinet. The rectified output pulses from T1702 secondary winding are smoothed by filter V1712, R1758 and applied to the POWER ON LED, which flashes once every second.

When the battery is fully charged, input 3 of D1704 is at a higher potential than the reference potential on input 2. This results in a high positive output on pin 6 and the charging circuits are disconnected; i.e. switching transistors V1722 and V1723 are cut off, in addition, the positive output on D1704 pin 6 is routed via zener diode V1743 to switch on transistor V1742. This results in a lower voltage of approx. 10x, on the base of transistor V1746 and consequently on unequal mark-space ratio from the bistable multivibrator. The RC-generator circuit V1748 is now generating for approximately 3 seconds and non-generating for 0.5 seconds. This causes the POWER ON LED to flash with a ½-second interruption every 3 seconds, denoting that the batteries are fully charged.

3.2.2. Trickle charge mode

In this mode, with the instrument connected to the mains and switched to POWER ON, the negative potential derived from the emitter of series regulator V217 (in the oscilloscope power supply) is applied via diodes V1728 and V1727 to cut off transistor V1726. This causes the potential at the junction of R1723, R1724 to be less negative, thereby causing input 3 of D1702 to be more positive than input 2.

Consequently, the resulting high positive output on pin 6 is applied via diode V1721 to cut off the switching transistor V1722. This leaves only the trickle-charge in operation, via switching transistor V1723 and resistor R1719. The trickle-charging current is regulated by choice of the circuit components to a maximum of 30 mA.

3.2.3. Mains operation

When the instrument is used on mains supply (instrument connected to the mains and switched to POWER ON) the base of transistor V1714 will be positive and this transistor will conduct. Now the base potential of transistor V1713 becomes low and transistor V1713 will be cut off. So, the contacts of relay K1702 are in rest-position and the instrument is supplied by the +28 V via diode V1717.

3.2.4. Battery operation

When the instrument is used only on batteries, both relay circuits K1701 and K1702 energise and the battery output is connected via the contacts of relay K1702 to the instrument positive supply rail.

A drop in the battery voltage to 22.3 V will result in input 2 of D1701 becoming higher than input 3. In this event, the output on pin 6 is low positive and transistor V1713 cuts off. No current is available for relay K1702 and the battery supply is therefore disconnected from the instrument by relay contacts K1702.

The low positive output on pin 6 of D1701 is connected via feedback resistor R1709 to pin 3 to make it more negative. In this way, the instrument remains off and the battery only delivers a slight current (approx. 20 mA) to its control circuit. To safeguard against discharging the batteries completely, relay K1701 drops out at approximately 18 V and disconnects the control circuits.

3.2.5. External battery supply

The provision for external batteries is via the isolating diode V1718 and the rest-position of the relay K1702 contacts. By means of the positive potential, via diode V1719, transistor V1714 is conductive when external batteries are used. This transistor serves to switch off V1713, which ensures that the relay K1702 is not energised; i.e. the external batteries are connected direct to the instrument positive supply rail via the rest-contacts of K1702.

3.3. CHECKING AND ADJUSTING THE INTERNAL BATTERY CONTROL CIRCUIT

WARNING: The opening of covers or removal of parts, except those to which access can be gained by hand, is likely to expose live parts, and also accessible terminals may be live. The instrument shall be disconnected from all voltage sources before any adjustment, replacement or maintenance and repair during which the instrument will be opened. If afterwards any adjustment, maintenance or repair of the opened instrument under voltage is inevitable, it shall be carried out only by a qualified person who is aware of the hazard involved. Bear in mind that capacitors inside the instrument may still be charged even if the instrument has been separated from all voltage sources.

3.3.1. General information

The following information provides the complete checking and adjusting procedure for the internal battery control circuit. As various control functions are interdependent, a certain order of adjustment is often necessary.

The procedure is, therefore, presented in a sequence which is best suited to this order, cross-reference being made to any circuit which may affect a particular adjustment.

Before any check or adjustment, the instrument must attain an ambient temperature of 15 ... 40 °C, as indicated in table 1.

- Where possible, instrument performance is checked before an adjustment is made.
- Warming-up time under average conditions is 30 minutes.
- All limits and tolerances given in this section are calibration guides and should not be interpreted as instrument specifications unless they are also published in chapter 1.2. characteristics.
- Tolerances given are for the instrument under test and do not include test equipment error.

Note: Do not check and adjust the instrument in a draughty room, because of the adverse effects of draught.

3.3.2. LO-LIM CUT-OUT CIRCUIT

- Disconnect the instrument from the mains.
- Disconnect the battery connections from the control unit.
- Connect an external power supply (0 ... 30 V, 1,5 A), terminated with a resistance of 47Ω , 25 W, to the battery connections on the control unit. The + output of the power supply must be connected to the connection pin with the red dot and the – output to the other connection pin.
- Connect in series with the positive supply line a mA-meter class 2, ranges 1 A and 100 mA.
- Adjust the output voltage of the external power supply to $26 \text{ V} \pm 1 \text{ V}$.
- Switch on the instrument.
- Decrease the output voltage of the external power supply to such a value, that relay K1702 just releases. Check with a digital voltmeter that the voltage is $22.3 \text{ V} \pm 50 \text{ mV}$ the voltage drop across the mA-meter added.

If the release voltage is not within the above mentioned tolerance proceed as follows:

- Turn potentiometer R1703 fully to the left.
- Increase the output voltage of the external power supply until relay K1702 just becomes effective.
- Now adjust the output voltage of the external power supply to $22.3 \text{ V} \pm 50 \text{ mV}$ (measure with digital voltmeter) the voltage drop across the mA-meter added.
- Turn potentiometer R1703 slowly to the right until relay K1702 just releases.

Slowly increase the output voltage of the external power until relay K1702 just becomes effective again. This must happen between 24 and 28 V.

3.3.3. Hi-LIM CUT-OUT circuit

- Switch of the instrument.
- Adjust the external power supply to $26 \text{ V} \pm 200 \text{ mV}$.
- Connect the instrument to the mains ($220 \text{ V} \pm 1.5 \%$).
- Check that the mA-meter indicates $300 \text{ mA} \pm 20 \text{ mA}$, if necessary, readjust potentiometer R1731.
- Increase the mains voltage to $242 \text{ V} \pm 1.5 \%$, check that the mA-meter indicates a current of $\leq 450 \text{ mA}$.
- Decrease the mains voltage to $198 \text{ V} \pm 1.5 \%$, check that the mA-meter indicates a current of $\geq 150 \text{ mA}$.
- Adjust the mains voltage to $220 \text{ V} \pm 1.5 \%$ again.
- Switch the instrument ON, check that the mA-meter indicates a current of 5 ... 30 mA.
- Switch the instrument OFF.
- Now adjust the external power supply to a value belonging to the ambient temperature as indicated in table 1. Check that the mA-meter indicates a current of 100 ... 150 mA, if necessary readjust potentiometer R1742.

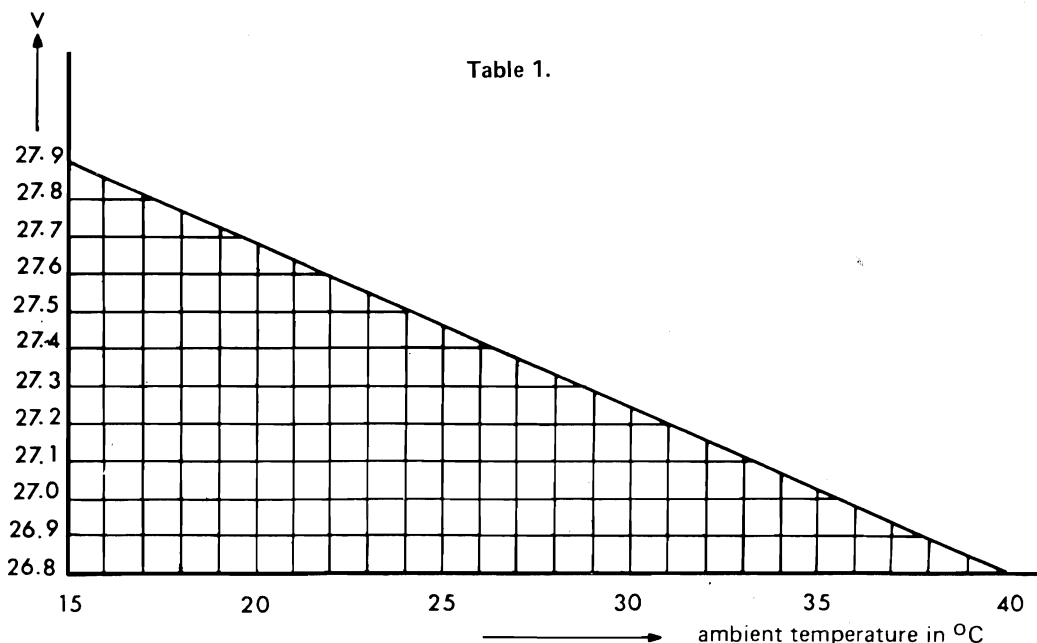

3.3.4. Blinking frequency of the pilot lamp indicating the state of the battery charge

- Increase the external power supply output voltage 100 mV in respect of the voltage set as indicated in table 1.
- Check that the mA-meter indicates a current of ≤ 30 mA.
- Check that the pilot lamp (LED B1) blinks once per second.
- Decrease the external power supply output voltage 100 mV in respect of the voltage set, as indicated in table 1.
- Check that the pilot lamp blinks once every second.
- Remove the external power supply.
- Connect the mA-meter between the battery connection pins on the control unit.
- Check that the mA-meter indicates a current of ≤ 425 mA.
- Switch the instrument ON.
- Check that the mA-meter indicates a current of ≤ 70 mA.
- Switch off the instrument.
- Disconnect the instrument from the mains.
- Disconnect the mA-meter.
- Connect the batteries to the control unit again (red wire to the connection pin with the red dot).

3.3.5. Final check

- Switch on the instrument and discharge the batteries.
- Switch off the instrument and connect it to the mains. Charge the batteries during 16 hours.
- Disconnect the instrument from the mains and switch on. Discharge the batteries with scale illumination to minimum. Discharging time 2.5 ... 3.5 hours.
- Connect the instrument to the mains and switch on.
- Charge the batteries during 24 hours.

3.4. BATTERY INFORMATION

3.4.1. Charging- and discharging curves

For a correct operating time it is very important that the batteries used together in an instrument in same state of charge, as the batteries are connected in series they share the same charging- and discharging currents.

Example I shows the curves for a set-up of 3 batteries of 8 V each in a correct situation.

Example II shows one battery already partly discharged.

Results: – two batteries will be charged too much in charging cycle
 – one battery will be too much discharged in discharging cycle

Hence: short operating time.

If you are in doubt about the matching of the batteries due to a short operating time, charge each battery on a separate supply.

Use a power supply with current-limitation at about 1/10 of the battery-capacitance and an open output voltage of 2.3 V for each cell that the battery comprises (i.e. 9.2 V).

Doing so you will get a good "starting position" as shown in example I.

3.4.2. Defective battery

A defective battery can be detected by measuring the voltage between "+" and "-" terminal in loaded condition (inside a switched-on instrument) and comparing them with the other battery terminal-voltages. This should be done with batteries in charged condition; in case of doubt first charge each battery separately.

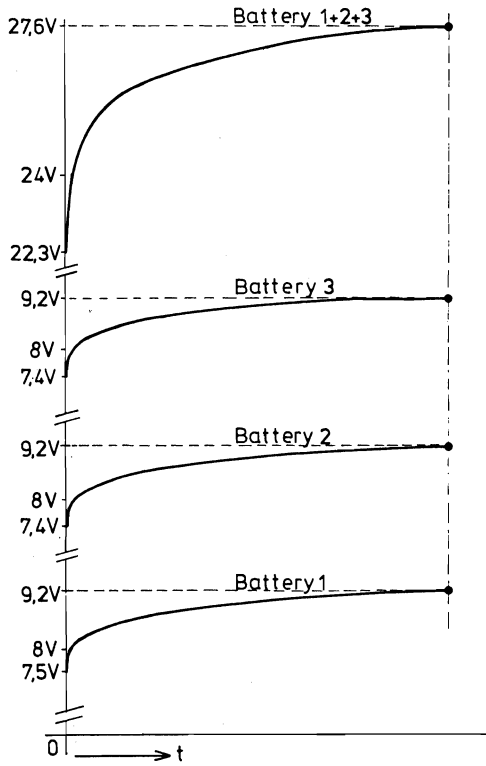

EXAMPLE I: charge curves

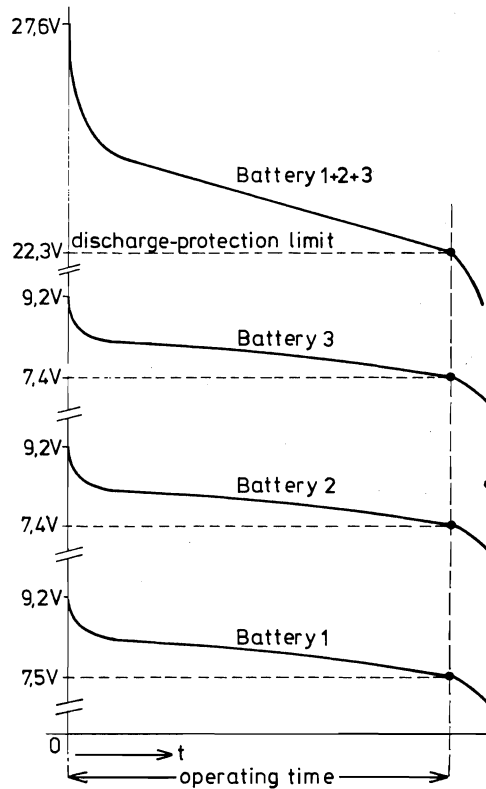

EXAMPLE I: discharge curves

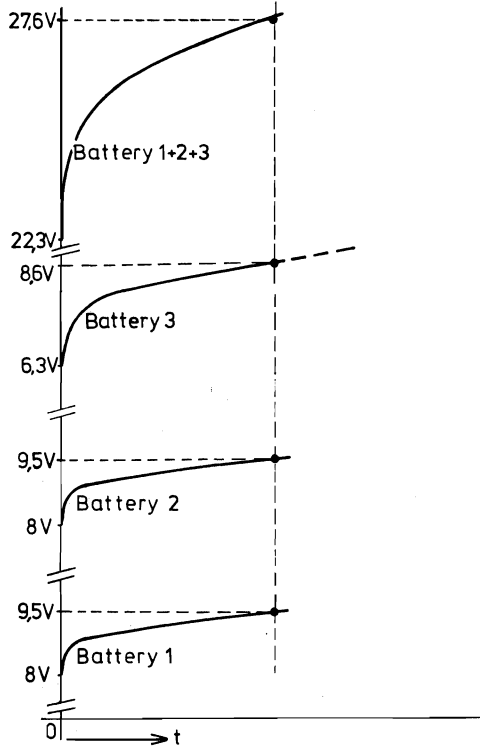

EXAMPLE II: charge curves

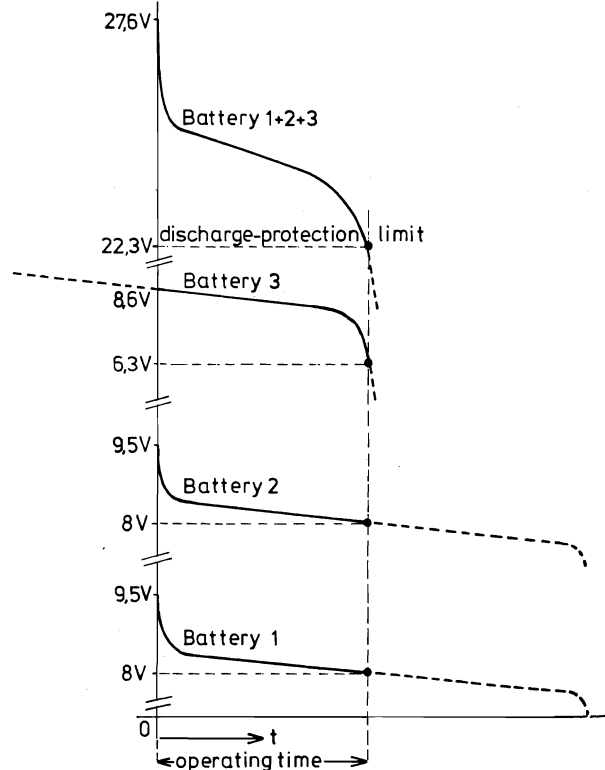

EXAMPLE II: discharge curves

MAT1

Fig. 1. Charging and discharging curves

3.5. PARTS LIST

Capacitors

Item	Ordering number	Farad	Tol. (%)	Volts	Description
C1701	4822 124 20484	15 μ	-10/+50	40	Electrolytic
C1702	5322 121 40323	100 μ	10	100	Polyester
C1703	5322 121 40323	100 μ	10	100	Polyester
C1704	4822 124 20484	15 μ	-10/+50	40	Electrolytic
C1706	4822 124 20484	15 μ	-10/+50	40	Electrolytic
C1707	4822 122 31222	220 p	2	100	Ceramic
C1708	4822 122 31222	220 p	2	100	Ceramic
C1709	4822 122 31222	220 p	2	100	Ceramic
C1711	4822 124 20482	2.2 μ	-10/+50	40	Electrolytic
C1712	4822 124 20484	15 μ	-10/+50	40	Electrolytic

Resistors

Item	Ordering number	Ohm	Tol. (%)	Type	Remarks
R1701	5322 116 50479	15,4 K	1	MR25	Metal film
R1702	5322 116 54595	5,11 K	1	MR25	Metal film
R1703	5322 100 10118	22 K	20	0.5 W	Pre-set potentiometer
R1704	5322 116 50451	21,5 K	1	MR25	Metal film
R1706	5322 116.50608	6,19 K	1	MR25	Metal film
R1707	5322 116 54623	11 K	1	MR25	Metal film
R1708	5322 116 54595	5,11 K	1	MR25	Metal film
R1709	5322 116 50451	21,5 K	1	MR25	Metal film
R1711	5322 116 54643	20,5 K	1	MR25	Metal film
R1712	5322 116 54643	20,5 K	1	MR25	Metal film
R1713	5322 116 50479	15,4 K	1	MR25	Metal film
R1714	5322 116 54595	5,11 K	1	MR25	Metal film
R1716	5322 116 50479	15,4 K	1	MR25	Metal film
R1717	5322 116 54595	5,11 K	1	MR25	Metal film
R1718	4822 112 21045	4,7	5	4,2 W	Wire wound
R1719	5322 116 54448	59	1	MR25	Metal film
R1721	5322 116 54595	5,11 K	1	MR25	Metal film
R1722	5322 116 50479	15,4 K	1	MR25	Metal film
R1723	5322 116 54627	13,3 K	1	MR25	Metal film
R4724	5322 116 54627	13,3 K	1	MR25	Metal film
R1726	5322 116 54696	100 K	1	MR25	Metal film
R1727	5322 116 54595	5,11 K	1	MR25	Metal film
R1728	5322 116 54558	8,25 K	1	MR25	Metal film
R1729	5322 116 50479	15,4 K	1	MR25	Metal film
R1731	5322 100 10118	22 K	20	0,5 W	Pre-set potentiometer
R1732	5322 116 54643	20,5 K	1	MR25	Metal film
R1733	5322 116 54619	10 K	1	MR25	Metal film
R1734	5322 116 54619	10 K	1	MR25	Metal film
R1736	5322 116 54619	10 K	1	MR25	Metal film
R1737	5322 116 54643	20,5 K	1	MR25	Metal film

Item	Ordering number	Ohm	Tol. (%)	Type	Remarks
R1738	5322 116 54558	8,25 K	1	MR25	Metal film
R1739	5322 116 54668	44,2 K	1	MR25	Metal film
R1741	5322 116 50442	48,7 K	1	MR25	Metal film
R1742	5322 100 10118	22 K	20	0,5 W	Pre-set potentiometer
R1743	5322 116 54643	20,5 K	1	MR25	Metal film
R1744	5322 116 54619	10 K	1	MR25	Metal film
R1746	5322 116 54549	1 K	1	MR25	Metal film
R1747	5322 116 54668	42,2 K	1	MR25	Metal film
R1748	5322 116 54727	205 K	1	MR25	Metal film
R1749	5322 116 54727	205 K	1	MR25	Metal film
R1750	5322 116 54558	8,25 K	1	MR25	Metal film
R1751	5322 116 54696	100 K	1	MR25	Metal film
R1752	5322 116 54558	8,25 K	1	MR25	Metal film
R1753	5322 116 54643	20,5 K	1	MR25	Metal film
R1754	5322 116 54619	10K	1	MR25	Metal film
R1756	5322 116 54619	10 K	1	MR25	Metal film
R1757	5322 116 54549	1 K	1	MR25	Metal film
R1758	5322 116 50679	237	1	MR25	Metal film

Diodes

Item	Ordering number	Type
V1701	5322 130 30414	BY164
V1702	5322 130 30613	BAW62
V1703	5322 130 34281	BZX79 - C15
V1704	5322 130 30613	BAW62
V1707	5322 130 34490	BZX79 - B20
V1708	5322 130 34197	BZX79 - C12
V1709	5322 130 34048	BZX75 - C2V8
V1711	5322 130 30613	BAW62
V1712	5322 130 34048	BZX75 - C2V8
V1716	5322 130 34499	BZX79 - B20
V1717	5322 130 34633	BY227
V1718	5322 130 34633	BY227
V1719	5322 130 30613	BAW62
V1721	5322 130 30613	BAW62
V1724	5322 130 30613	BAW62
V1727	5322 130 34048	BZX75 - C2V8
V1728	5322 130 30613	BAW62
V1729	5322 130 30432	BYX36-150
V1731	5322 130 30432	BYX36-150
V1732	5322 130 30432	BYX36-150
V1733	5322 130 34278	BZX79/C6V8
V1734	5322 130 30613	BAW62
V1736	5322 130 30613	BAW62
V1737	5322 130 34382	BZX79-C8V2
V1738	5322 130 30765	BZX75-C3V6

Item	Ordering number	Type
V1739	5322 130 30765	BZX75-C3V6
V1741	5322 130 30765	BZX75-C3V6
V1743	5322 130 34999	BZX79-B20
V1747	5322 130 30613	BAW62
V1749	5322 130 30613	BAW62
V1751	5322 130 30613	BAW62
V1752	5322 130 30613	BAW62
V1753	5322 130 30613	BAW62

Transistors

Item	Ordering number	Type
V1706	5322 130 44461	BC546B
V1713	5322 130 44461	BC546B
V1714	5322 130 44461	BC546B
V1722	5322 130 44357	BD262
V1723	5322 130 40665	BD138
V1726	5322 130 44461	BC546B
V1742	5322 130 44461	BC546B
V1744	5322 130 44461	BC546B
V1746	5322 130 44461	BC546B
V1748	5322 130 44461	BC546B

Integrated circuits

Item	Ordering number	Type
D1701	5322 209 85294	LM741CN
D1702	5322 209 85254	LM741CN
D1704	5322 209 85254	LM741CN
D1705	5322 209 85254	LM741CN

Miscellaneous

Item	Fig.	Qty.	Ordering number	Description
1	6	1	5322 280 24131	Reed relay assy. K1701
2	6	1	5322 280 84087	Relay K1702
3	6	1	5322 281 64154	Coil L1701
4	7	1	5322 146 44038	Mains transformer for B-version T1701
5	6	1	5322 142 64068	Transformer T1702
6	6	1	5322 216 54154	Control unit A1701

3.6. CIRCUIT DIAGRAMS

BLOCK-DIAGRAM

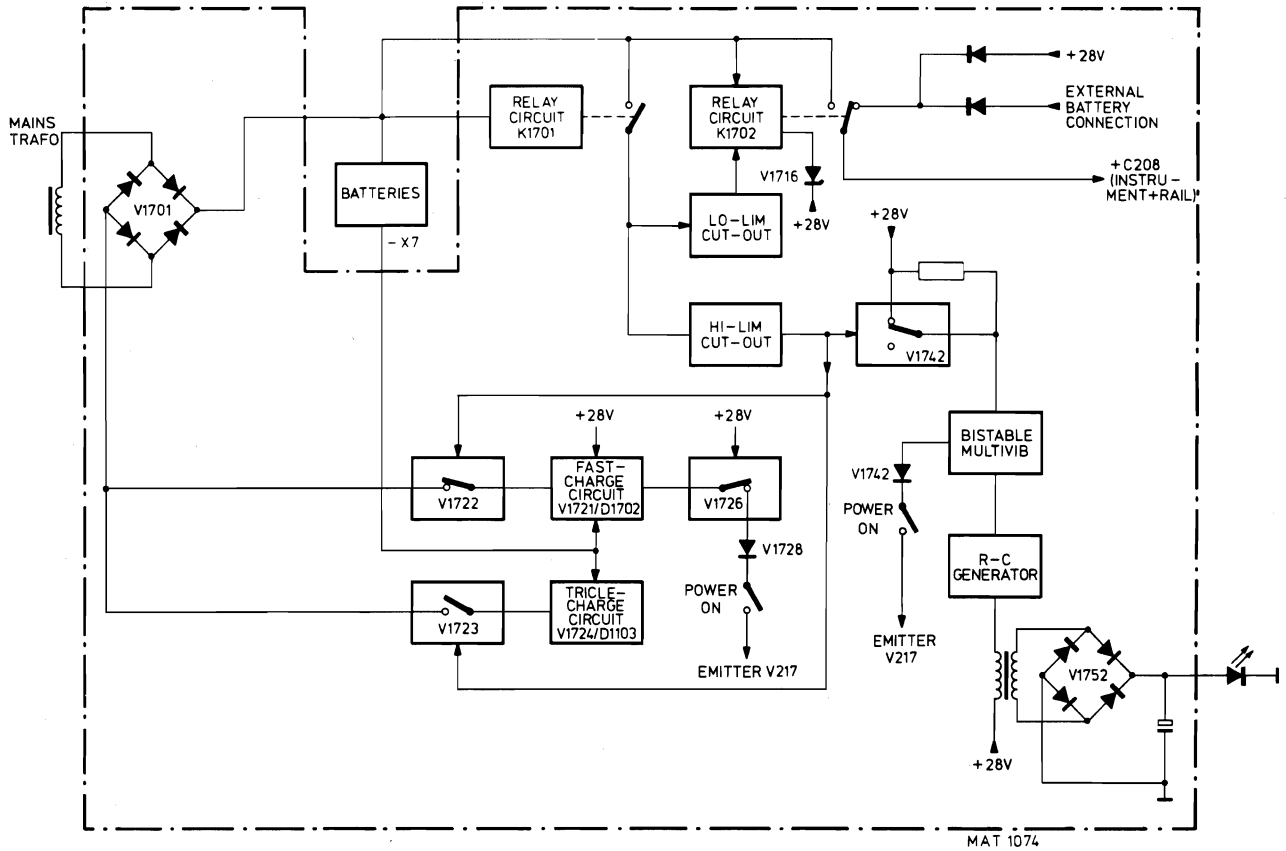

Fig. 2. Block diagram of the battery supply unit

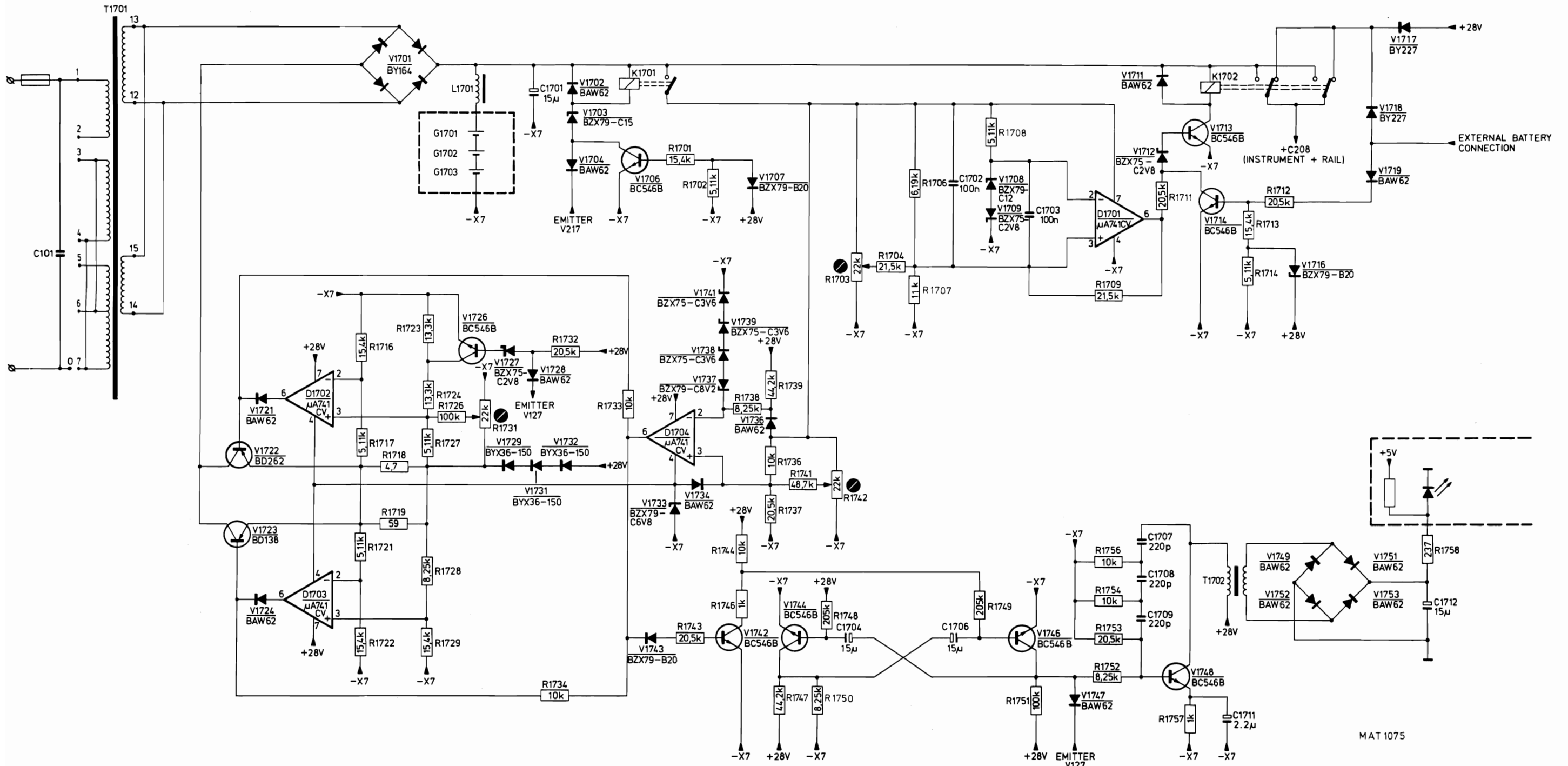

Fig. 3. Circuit diagram of the battery supply unit

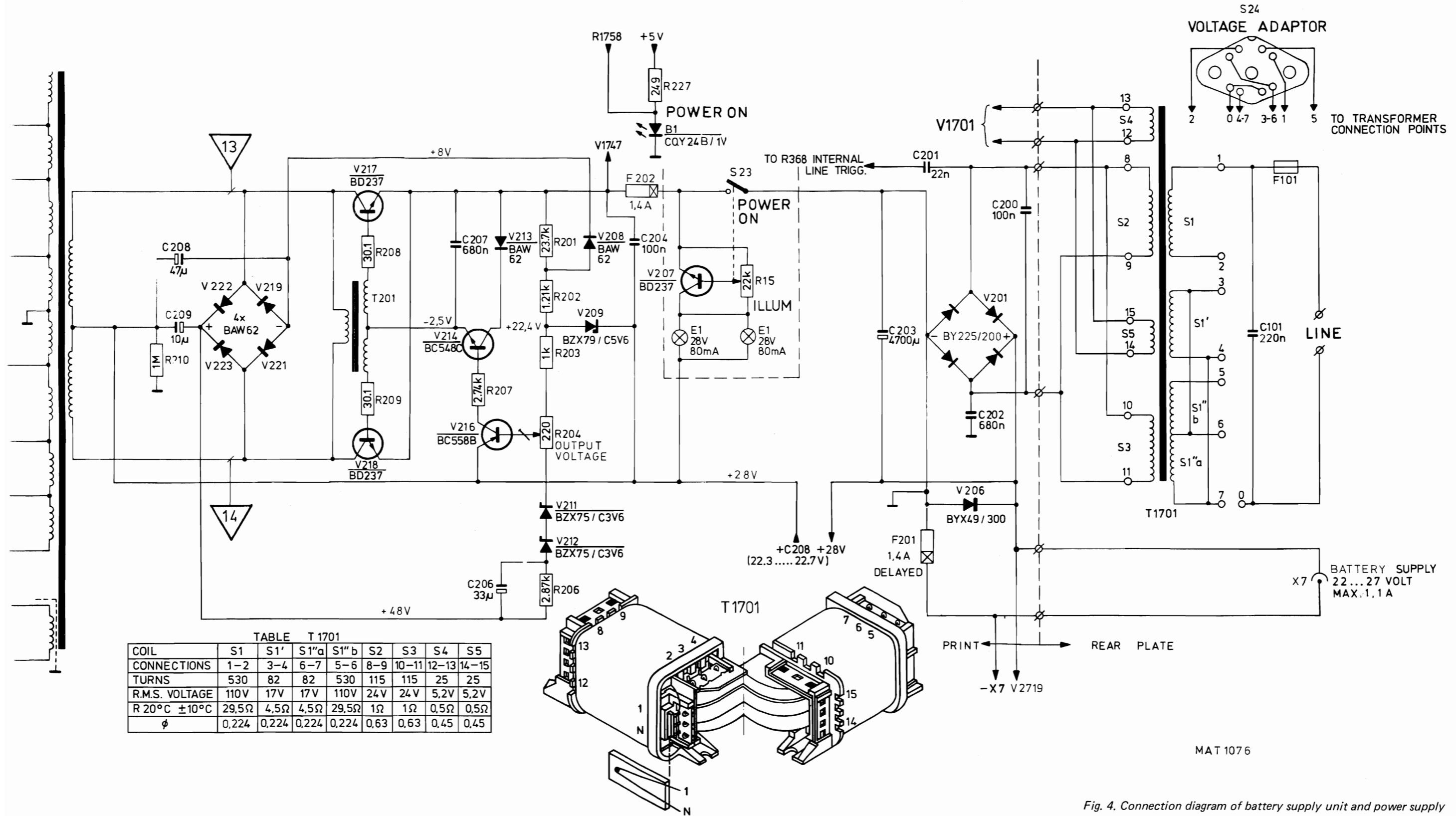
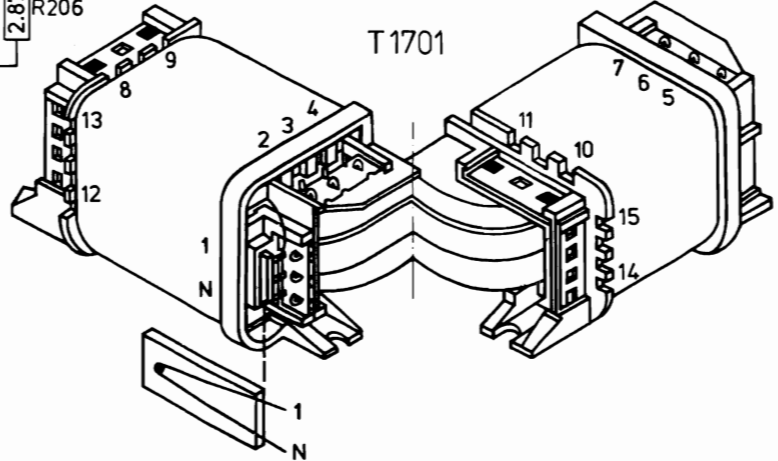

TABLE T 1701

COIL	S1	S1'	S1''a	S1''b	S2	S3	S4	S5
CONNECTIONS	1-2	3-4	6-7	5-6	8-9	10-11	12-13	14-15
TURNS	530	82	82	530	115	115	25	25
R.M.S. VOLTAGE	110V	17V	17V	110V	24V	24V	5.2V	5.2V
R 20°C ±10°C	29,5Ω	4,5Ω	4,5Ω	29,5Ω	1Ω	1Ω	0,5Ω	0,5Ω
φ	0,224	0,224	0,224	0,224	0,63	0,63	0,45	0,45



MAT 1076

Fig. 4. Connection diagram of battery supply unit and power supply

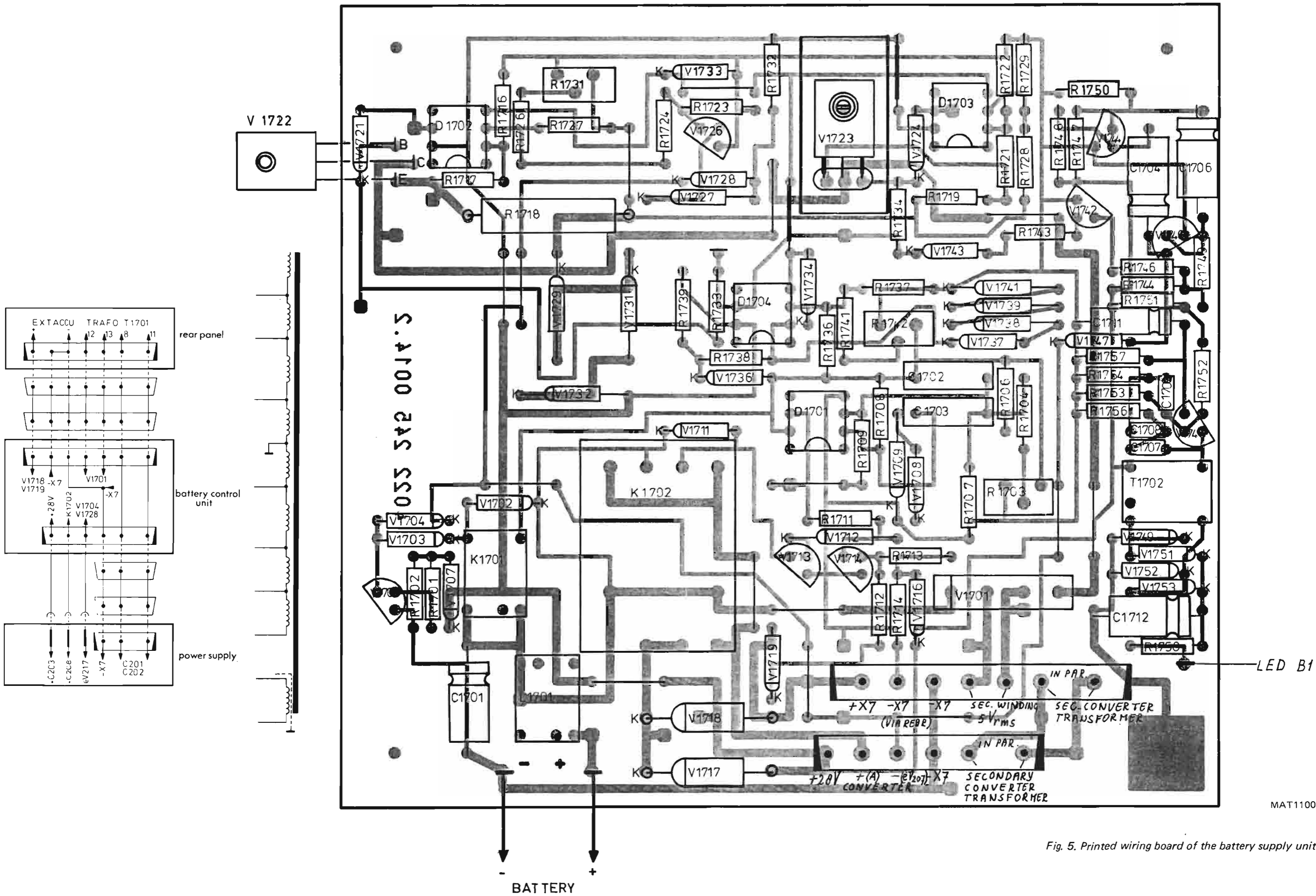

Fig. 5. Printed wiring board of the battery supply unit

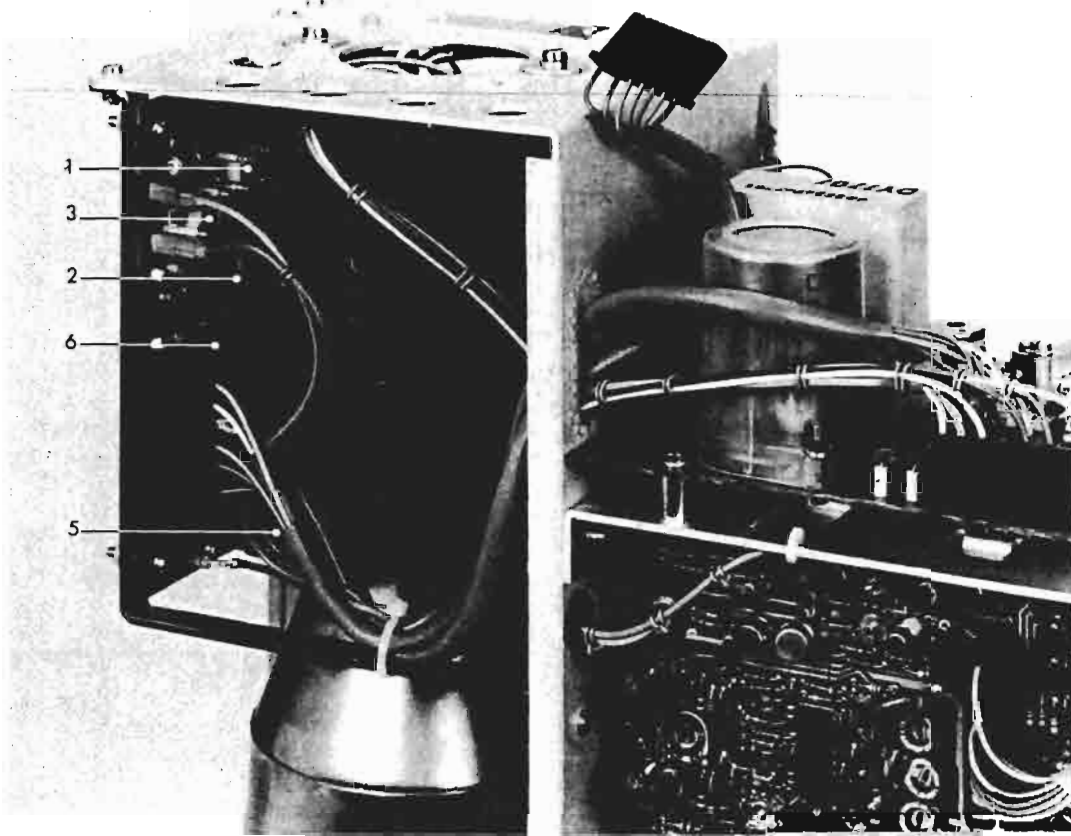

Fig. 6.

MAT1093

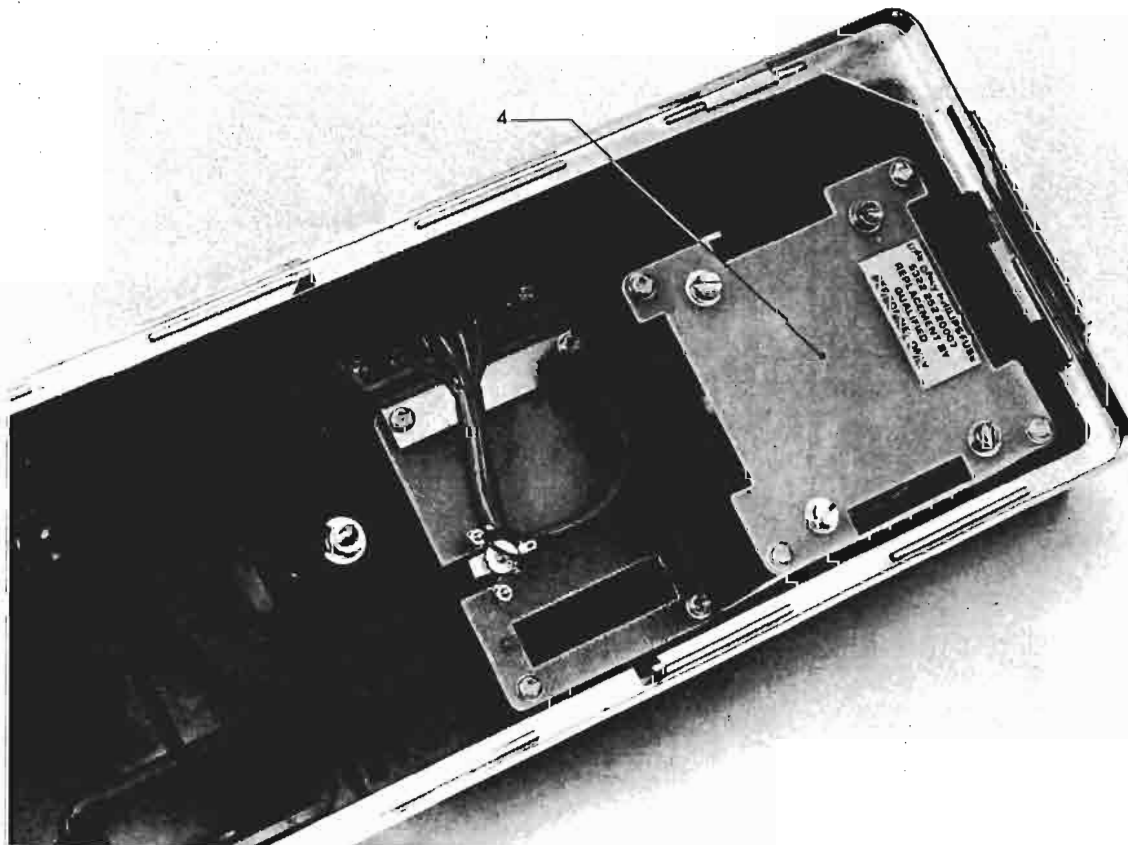

Fig. 7.

MAT1094